



www.larius.com

VIKING LINER PLUS

Airless professional road marking

Bicomponent version 2k 1:1

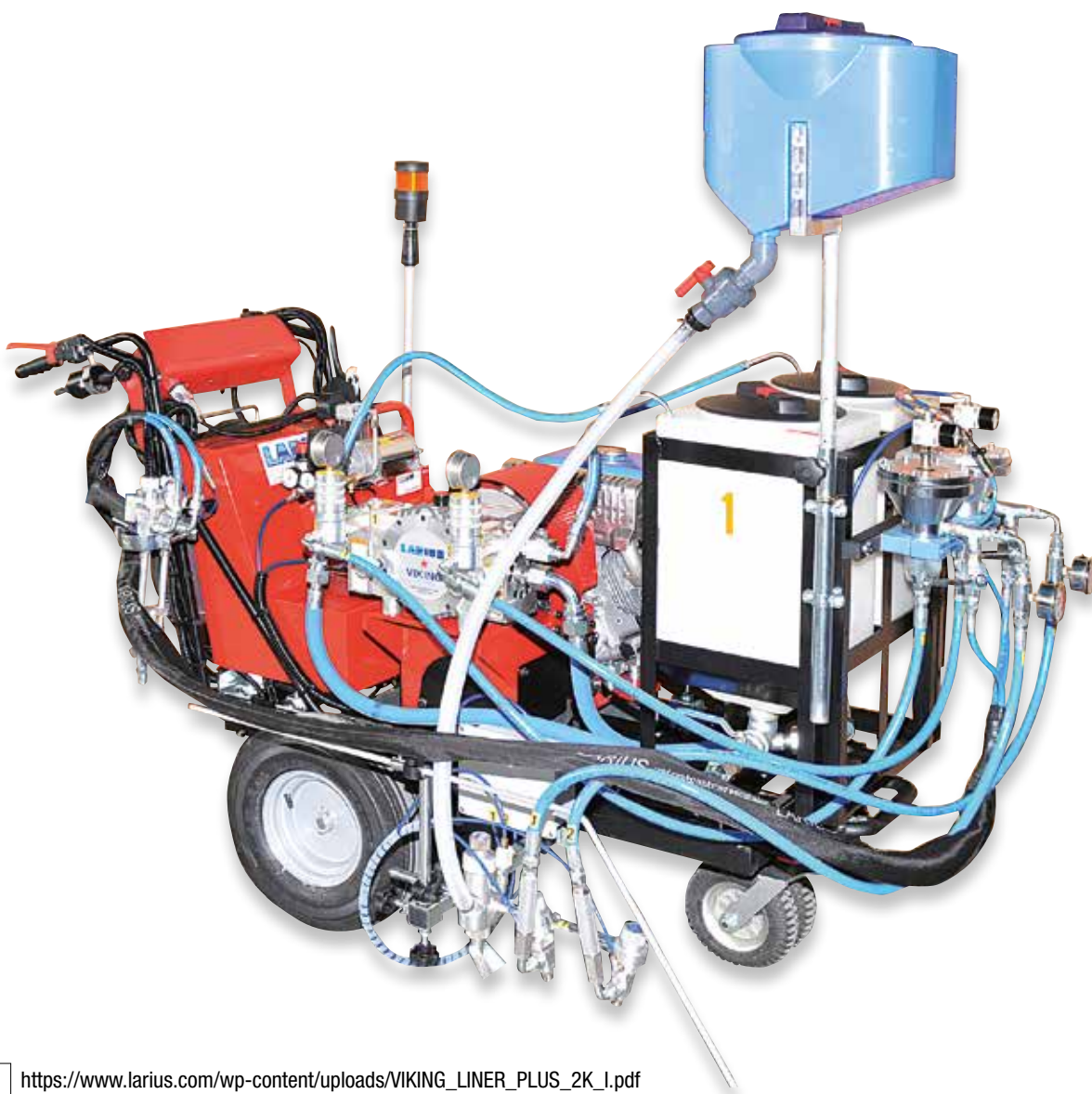

IT https://www.larius.com/wp-content/uploads/VIKING_LINER_PLUS_2K_I.pdf

EN https://www.larius.com/wp-content/uploads/VIKING_LINER_PLUS_2K_UK.pdf

Intentionally blank page

The ideal choice for achieving professional performance.

WELL PROVEN TECHNICAL QUALITY FOR ANY ON-GROUND MARKING APPLICATION

The airless line markers successfully join product performance with operator requirements and allow the marking and the maintenance of any kind of pavement lines on roads, motorways, airports, pedestrian crossings, cycle paths, yards and wherever is required by the Highway Code with regards to horizontal road signs, guaranteeing perfect lines on different surfaces.

The airless technology provides the high pressure spraying of the paint through a nozzle having centesimal dimensions as compared to the traditional low pressure spraying in which the paint flow is atomized through the air contribution.

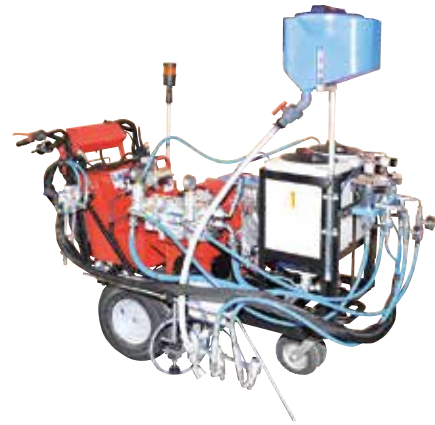

Advantages of use

Net and clear lines on any kind of pavement with one coat only.

With a single coat the line is defined evenly: the line made by airless spraying is linear, clean-cut and marked thanks to the flat cut nozzle and without the jagged due to the turbulences caused by air.

Reduction of Over spray.

The airless operated marking guarantees the absence of the classic "Overspray", that is the dispersion of paint particles which is typical in the traditional air painting.

This translates, further than in a saving of paint, in a better protection for health of the operator and for environment.

Saving of paint up to 30%.

Thanks to the absence of Overspray almost all of the used product is applied on the surface without any waste.

Reduction of the vibrations.

The reduction of the vibrations ensures the best in industry quality of lines.

The paint dries quickly.

The airless operation requires that filtered paint specifically formulated for airless application is used, this means, by itself, even paint, smooth and uniform texture which will not return any crust nor will become neither jelly-like nor thick.

The paint holds tightly on any kind of pavement, with an excellent visibility and resistance to wear caused both by traffic and weather elements.

High quality paints guarantee a faster application speed, a better durability of the visibility of the line and a pleasant aesthetic result.

Reflective bead application.

Reflective beads can be applied using a gravity dispenser operated by the same command which operates

the paint gun. The spheres automatically fall onto the freshly marked line. No paints with pre-mixed beads can be used.

50 litre non-stick hopper.

Thanks to the big capacity of the hopper marking times are extended thanks to the absence of frequent interruptions to perform colour changes.

Template works and curved marking.

The gun can be released from its support in just a few seconds and, thanks to the 10 meters pipe it is connected to, it allows any template work, on walls as well.

The front wheel helps to mark lines close to the kerb and to mark arches and curves.

Intuitive use by the operator.

The operator commands are located right on the handlebar to adjust the operation of the line marker in the most handy way.

Optional equipment.

Airless line markers can be equipped basing on the different needs of the operator for offering a dedicated solution for any marking need.

Easy cleaning and maintenance.

Cleaning airless line markers is quick thanks to the absence of pressurized tanks to be cleaned and thus colour change times are extremely short both if using the can or the non stick paint tank. The high pressure of the airless line marker clears the spraying area from dirt and so it does not require that the ground is previously cleaned.

A regular cleaning at the end of the work is sufficient to keep the machine in perfect efficiency, even after prolonged standing periods.

The Super Fast Clean airless nozzles allow that the nozzle is cleaned with a simple rotating movement, without any need to detach it.



This manual is to be considered as an English language translation of the original manual in Italian. The manufacturer shall bear no responsibility for any damages or inconveniences that may arise due to the incorrect translation of the instructions contained within the original manual in Italian.

Due to a constant product improvement programme, the factory reserves the right to modify technical details mentioned in this manual without prior notice.

VIKING LINER PLUS 2K

Professional road marking self-propelled

INDEX













INTRODUCTION		P CORRECT PROCEDURE OF DECOMPRESSION	p.26
WARNINGS	p.2	Q EXPLODED VIEW GUN LA 95	p.28
A WORKING PRINCIPLE	p.3	R COMPLETE COLOUR BODY	p.29
B TECHNICAL DATA	p.4	S COMPLETE HYDRAULIC BODY	p.30
C DESCRIPTION OF THE EQUIPMENT	p.6	T COMPLETE PUMP MOTOR BODY	p.32
D TRANSPORT AND UNPACKINGO	p.11	U CARTER	p.34
E SAFETY RULES	p.11	V ALTERNATOR	p.35
F SETTING-UP	p.12	W FLOW REGULATOR	p.36
G OPERATION	p.18	X TANKS	p.36
H PAINTING OPERATIONS	p.16	Y CONTROL LEVER MECHANISMS	p.37
I CATADIOPTRIC PEARLS DISTRIBUTING KIT	p.19	Z SPARE PARTS	p.38
J ADJUSTMENTS	p.20	AA CONTROL PANEL USE.....	p.40
K CLEANING AT THE END OF WORK.....	p.21	BB LINES SEQUENCING FUNCTION	p.42
L GENERAL MAINTENANCE.....	p.22	CC ACCESSORIES	p.45
M ROUTINE MAINTENANCE	p.22	CERTIFICATION OF CONFORMITY	p.51
N DESCRIPTION OF CONTROLS.....	p.23		
O TROUBLESHOOTING.....	p.25		

**WE ADVISE THE USE OF THIS EQUIPMENT ONLY BY PROFESSIONAL OPERATORS.
ONLY USE THIS MACHINE FOR USAGE SPECIFICALLY MENTIONED IN THIS MANUAL.**

Thank you for choosing a **SAMOA** product.
As well as the product purchased, you will receive a range of support services
enabling you to achieve the results desired, quickly and professionally.

WARNINGS

The table below provides the meaning of the symbols used in this manual in relation to using, earthing, operating, maintaining, and repairing of this equipment.

	<p>Read this operator's manual carefully before using the equipment. An improper use of this machine can cause injuries to people or things. Do not use this machine when under the influence of drugs or alcohol. Do not modify the equipment under any circumstances. Use products and solvents that are compatible with the various parts of the equipment, and read the manufacturer's warnings carefully. See the Technical Details for the equipment given in the Manual. Check the equipment for worn parts once a day. If any worn parts are found, replace them using ONLY original spare parts. Keep children and animals away from work area. Comply with all safety standards.</p>
	<p>It indicates an accident risk or serious damage to equipment if this warning is not followed.</p>
	<p>It indicates a fire or explosion risk if this warning is not followed. Eliminate all ignition sources such as pilot lights, cigarettes, portable electric lamps and plastic drop cloths. Keep work area free of debris. ONLY use this equipment in a well ventilated area. EARTH ALL THE EQUIPMENT LOCATED IN THE WORK AREA. Do not form connections or switch light switches on or off if the air contains inflammable fumes. If electrical shocks or discharges are encountered the operation being carried out using the equipment must be stopped immediately. Keep a fire extinguisher at hand in the immediate vicinity of the work area.</p>
	<p>It indicates wound and finger squashing risk due to movable parts in the equipment. Tenersi lontano dalle parti in movimento. Do not use the equipment without the proper protection. Before any inspection or maintenance of the equipment, carry out the decompression procedure explained in this manual, and prevent any risk of the equipment starting unexpectedly.</p>
 	<p>Report any risk of chemical reaction or explosion if this warning has not been given. There is a risk of injury or serious lesion related to contact with the jet from the spray gun. If this should occur, IMMEDIATELY contact a doctor, indicating the type of product injected. Do not spray before the guard has been placed over the nozzle and the trigger on the spray gun. Do not put your fingers in the spray gun nozzle. Once work has been completed, before carrying out any maintenance, complete the decompression procedure explained in this manual.</p>
	<p>It indicates important recommendations about disposal and recycling process of products in accordance with the environmental regulations.</p>
	<p>Report any danger of electric shock if the warning and presence of live electrical parts has not been indicated. Store in a dry place and do not expose to the rain. Check that the cables are in good condition. Switch off the equipment and discharge any electricity before cleaning or maintaining the equipment.</p>
	<p>Mark any clamps attached to earth cables. Use ONLY 3-wire extension cords and grounded electrical outlets. Before starting work make sure that the electrical system is earthed and that it complies with safety standards.</p>
   	<p>It is obligatory to wear suitable clothing as gloves, goggles and face shield. Wear clothing that complies with the safety standards in force in the country in which the equipment is used. Do not wear bracelets, earrings, rings, chains, or anything else that may hinder the operator's work. Do not wear clothing with wide sleeves, scarves, ties, or any other piece of clothing that could get tangled up in moving parts of the equipment during the work, inspection, or maintenance cycles.</p>

A WORKING PRINCIPLE

The **VIKING LINER PLUS** is a professional bicomponent airless line marker 2K 1:1 with autotraction and automatic line sequencer and designed for performing road markings along particularly difficult tracts of uneven road where marking would otherwise be difficult to complete.

The internal combustion engine, mounted upon the undercarriage, powers the pump and the alternator which is employed for charging the battery unit. The two-wheel frontal-traction is powered by an electric motor which allows the operator to easily move, even on medium-grade inclines. The control zone offers the possibility of:

- Activating the two spraying guns;
- Enabling or disabling the frontal steering wheel;
- Enabling / disabling front-wheel traction;
- Gradually increasing the advancement speed of the self-propelled undercarriage;
- Selecting continuous or dotted line painting functionality.

This type of device is capable of marking one line at a time in a single colour.

The line can be continuous or dashed.

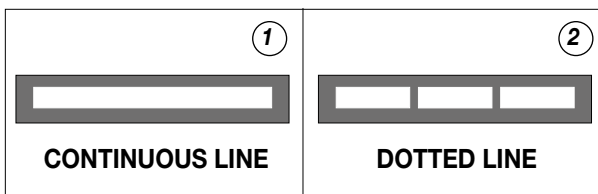

VIKING LINER PLUS is perfect for large-scale lining and maintenance works and uses specific bicomponent paint for airless applications.

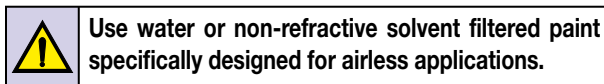

Use water or non-refractive solvent filtered paint specifically designed for airless applications.

VIKING LINER PLUS allows the marking and maintaining of all types of lines on highways, freeways, pedestrian crossings, parking lots and squares, as well as every horizontal marking required by the highway code.

Airless marking has numerous proven benefits with respect to line-markers with pressurised tanks, which have been rendered obsolete by airless-technology line markers.

Airless line-marking guarantees:

- Reduced Environmental Impact;
- Reduced drying time.

The paint dries quickly and the line is defined in an even manner with a single coat. The airless function requires the use of filtered paint which is specifically designed for airless application. This means that the paint is homogeneous, of a smooth and even consistency and will not form crusts, nor will it become gelatinous or thick. With this airless line-marker, the paint adheres firmly to all types of pavement, with optimal visibility and resistance to wear caused both by traffic and atmospheric agents.

The refractive effect is obtained through the release of refractive spheres from an appropriate tank. These spheres automatically “fall” onto the painted line and, for this reason, pre-mixed or beaded paints do not have to be used. The proper operation of the device is



granted by the exclusive use of suitable and quality paints. A high degree of safety and cleaning of the workplace is achieved thanks to the absence of pressurised tanks.

In the **VIKING LINER PLUS** model the paint is loaded directly into the non-stick tanks. In this case, cleaning, maintenance and colour change operations are easy to perform.



The line-marker is equipped with a 360° pivoting frontal wheel which even increases the agility of the larger models. High yield, high efficiency, high versatility.



This line-marker utilises non-premixed paints. This allows it to achieve a yield of about 30% more than standard line-markers. Every model is also an airless spray gun which can be used in the construction field together with washable products, enamels, breathable paints and flooring resins.

A vast range of accessories is available to satisfy any customer request.

WORKING PRINCIPLE

The **VIKING LINER PLUS** line marker uses a diaphragm pump. This pump is used for high pressure painting without air (from this process derives the term “airless”).

The pump is controlled by a motor coupled with a rubber belt. A cam shaft and a connecting rod allow to obtain the reciprocating motion necessary to the working of the “pumping group”

diaphragm. The diaphragm movement produces a “depression”. The product is sucked, pushed towards the pump outlet and then sent to the gun through the high pressure flexible hose. A mechanical device allows to adjust and control the pressure of the material coming out of the pump.

A safety valve avoiding overpressur guarantees the total reliability of the equipment.

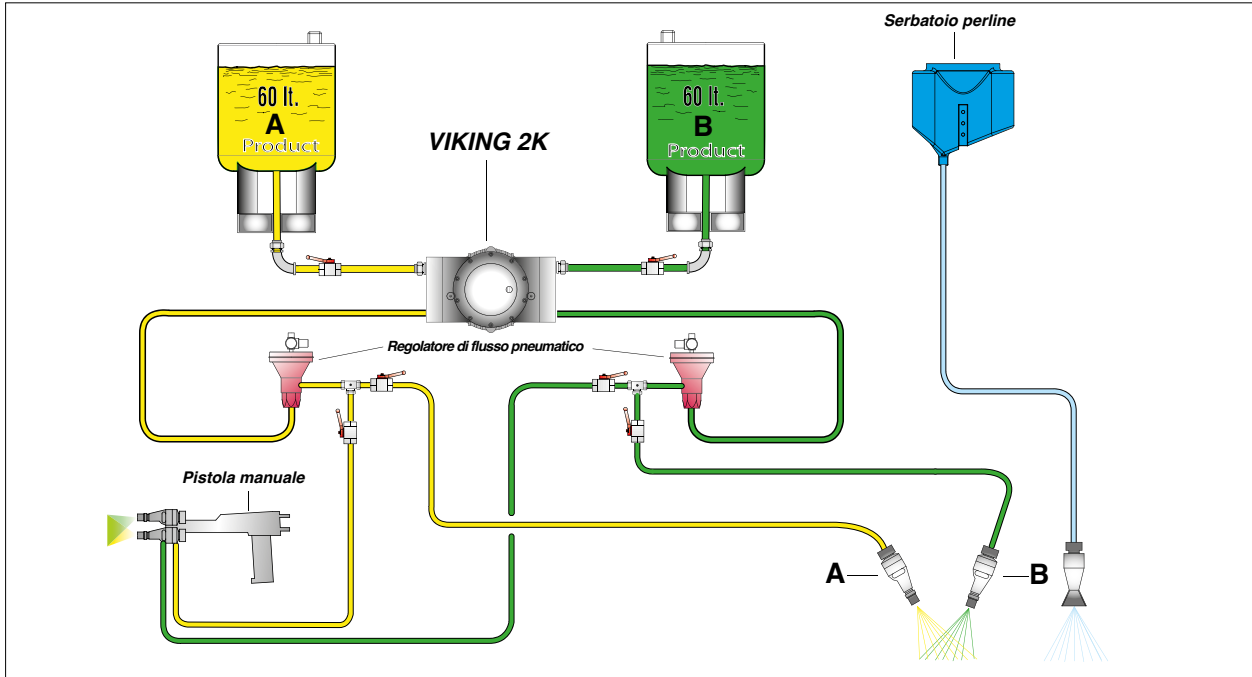

B TECHNICAL DATA

	VIKING LINER PLUS
SUPPLY	UNLEADED PETROL
MOTOR POWER	12,8 HP
MAX OPERATING PRESSURE	220 bar
MAX DELIVERY	3x2 L/min
WEIGHT	350 Kg
NOISE PRESSURE LEVEL	70Db(A)
LENGHT	(A) 2150 mm
WIDTH	(B) 1150 mm
HEIGHT	(C) 1750 mm

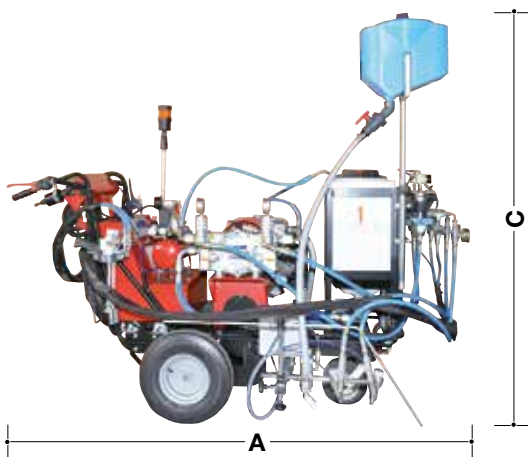
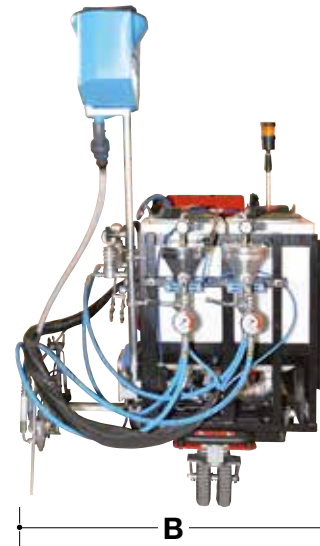

STANDARD EQUIPMENT		ACCESSORIES	MODELS
N° 2	Filters with pressure gauge	Rif. 4405/4	Rif. 4960
N° 2	Suction - recirculation systems	Pneumatic bead blasting gun	
N° 4	Super fast clean bases	Rif. 4038	
N° 2	Super fast clean nozzles 11-40	Laser pointer kit	
N° 2	Super fast clean nozzles 13-40	Rif. 4506	
N° 1	Tools pack	Working spotlight	
N° 1	Double twine 7,5 mt	Rif. 4711	
N° 1	Manual pneumatic gun Rif.11703	Operator platform	

APPLICATION FIELDS

- External or underground parking lots (schools, hotels, airports, supermarkets, train stations, subway stations, ports);
- External public areas;
- Industrial and exhibition building areas;
- Freeway service areas and service stations;
- Pedestrian median lines, intersections, bicycle tracks, reserved lanes;
- Internal and external logistic area markings;
- Playing fields.

SFC SPRAY TIPS/NOZZLES TABLE - TSC

Ø nozzle (inch)	Spray angle (°)	Line Width		Flow rate (gpm)	Flow rate (lpm)
		inch	mm		
.013	13 - 20	2 - 4	51 - 102	.18	.69
.015	15 - 20	2 - 4	51 - 102	.24	.91
	15 - 30	4 - 6	102 - 152		
.017	17 - 20	2 - 4	51 - 102	.31	1.17
	17 - 30	4 - 6	102 - 152		
	17 - 40	4 - 8	102 - 204		
.019	19 - 20	2 - 4	51 - 102	.38	1.47
	19 - 30	4 - 6	102 - 152		
	19 - 40	4 - 8	102 - 204		
.021	21 - 30	4 - 6	102 - 152	.47	1.79
	21 - 40	4 - 8	102 - 204		
	21 - 60	8 - 12	204 - 305		
.023	23 - 30	4 - 6	102 - 152	.57	2.15
	23 - 40	4 - 8	102 - 204		
	23 - 60	8 - 12	204 - 305		
.025	25 - 30	4 - 6	102 - 152	.67	2.54
	25 - 40	4 - 8	102 - 204		
	25 - 60	8 - 12	204 - 305		
.027	27 - 30	4 - 6	102 - 152	.77	2.96
	27 - 40	4 - 8	102 - 204		
	27 - 60	8 - 12	204 - 305		

Ø nozzle (inch)	Spray angle (°)	Line Width		Flow rate (gpm)	Flow rate (lpm)
		inch	mm		
.029	29 - 30	4 - 6	102 - 152	.90	3.42
	29 - 40	4 - 8	102 - 204		
	29 - 60	8 - 12	204 - 305		
.031	31 - 30	4 - 6	102 - 152	1.03	3.90
	31 - 40	4 - 8	102 - 204		
	31 - 60	8 - 12	204 - 305		
.033	33 - 30	4 - 6	102 - 152	1.17	4.42
.035	35 - 30	4 - 6	102 - 152	1.31	4.98
	35 - 40	4 - 8	102 - 204		
	35 - 60	8 - 12	204 - 305		
.039	39 - 30	4 - 6	102 - 152	1.63	6.18
	39 - 40	4 - 8	102 - 204		
	39 - 60	8 - 12	204 - 305		
.043	43 - 30	4 - 6	102 - 152	1.98	7.51
	43 - 40	4 - 8	102 - 204		
	43 - 60	8 - 12	204 - 305		

C DESCRIPTION OF THE EQUIPMENT

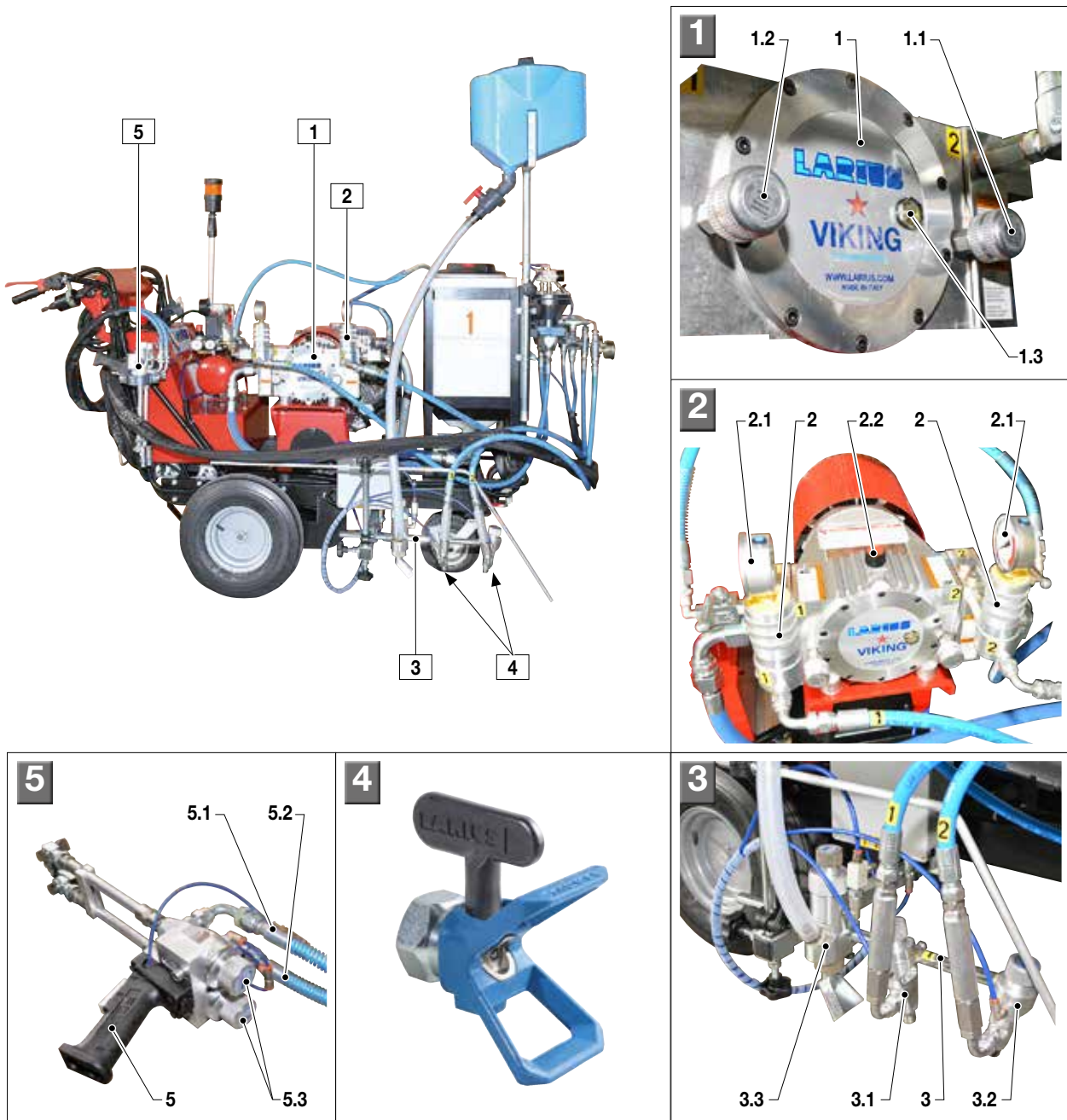

POS.	Description
1	Pumping group
1.1	Product pressure setting knob (1)
1.2	Product pressure setting knob (2)
1.3	Oil level check glass
2	Filter
2.1	Pressure gauge
2.2	Oil tap
3	Gun group
3.1	Product gun (1)

POS.	Description
3.2	Product gun (2)
3.3	Pearls gun
4	Super fast clean nozzle
5	Manual gun
5.1	Product tube (1)
5.2	Product tube (2)
5.3	Product application regulators

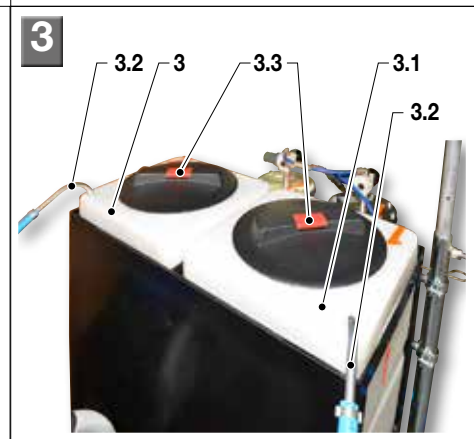
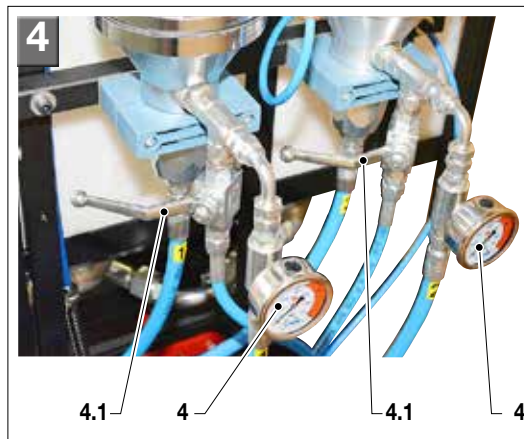
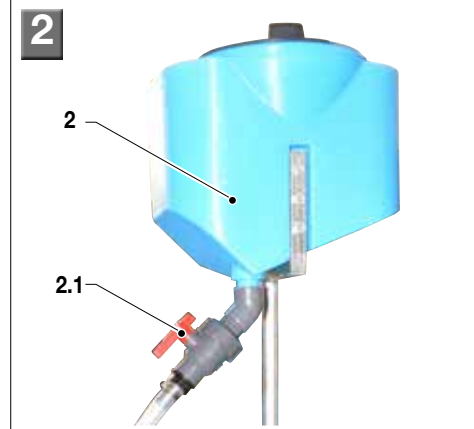
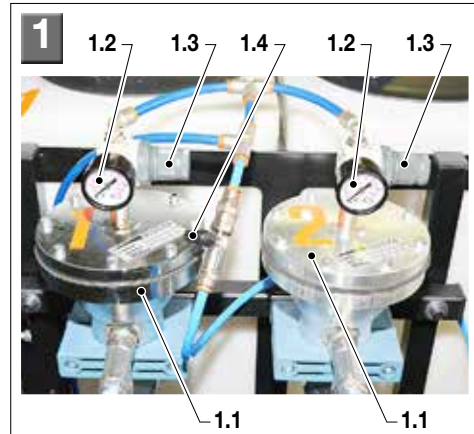
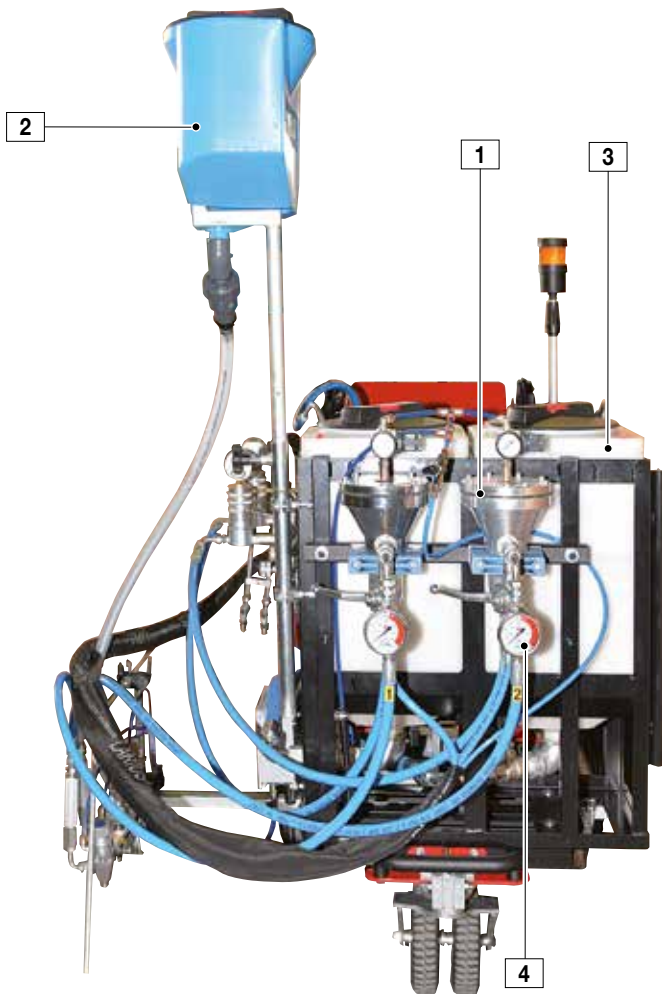

POS.	Description
1	Regulators unit
1.1	Pneumatic flow regulators
1.2	Pressure gauge
1.3	Pressure regulator
1.4	Manual air gun supply air valve
2	Bead tank
2.1	Manual bead descent valve

POS.	Description
3	Product tank (2)
3.1	Product tank (1)
3.2	Product recirculation tube
3.3	Tank fill cap
4	Product supply pressure gauge
4.1	Product supply manual open/close valve manual gun

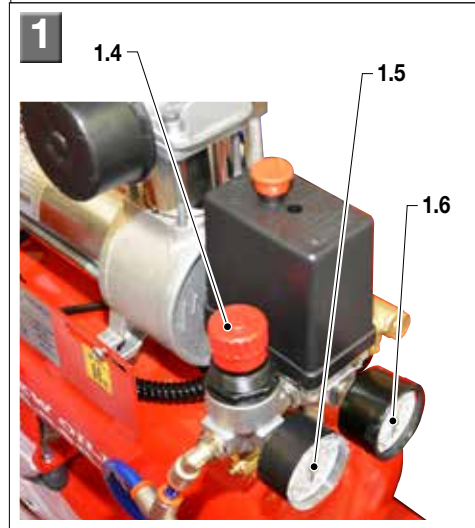
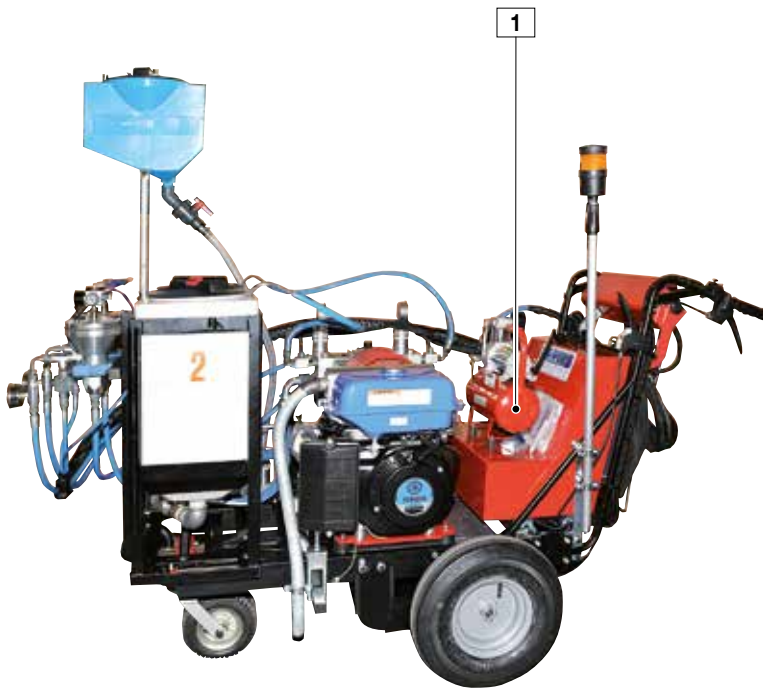

POS.	Description
1	Pneumatic system supply compressor
1.1	Compressor pressure switch
1.2	ON/OFF compressor button
1.3	Air filter

POS.	Description
1.4	Supplied pressure regulator
1.5	Supplied pressure gauge
1.6	Tank pressure gauge

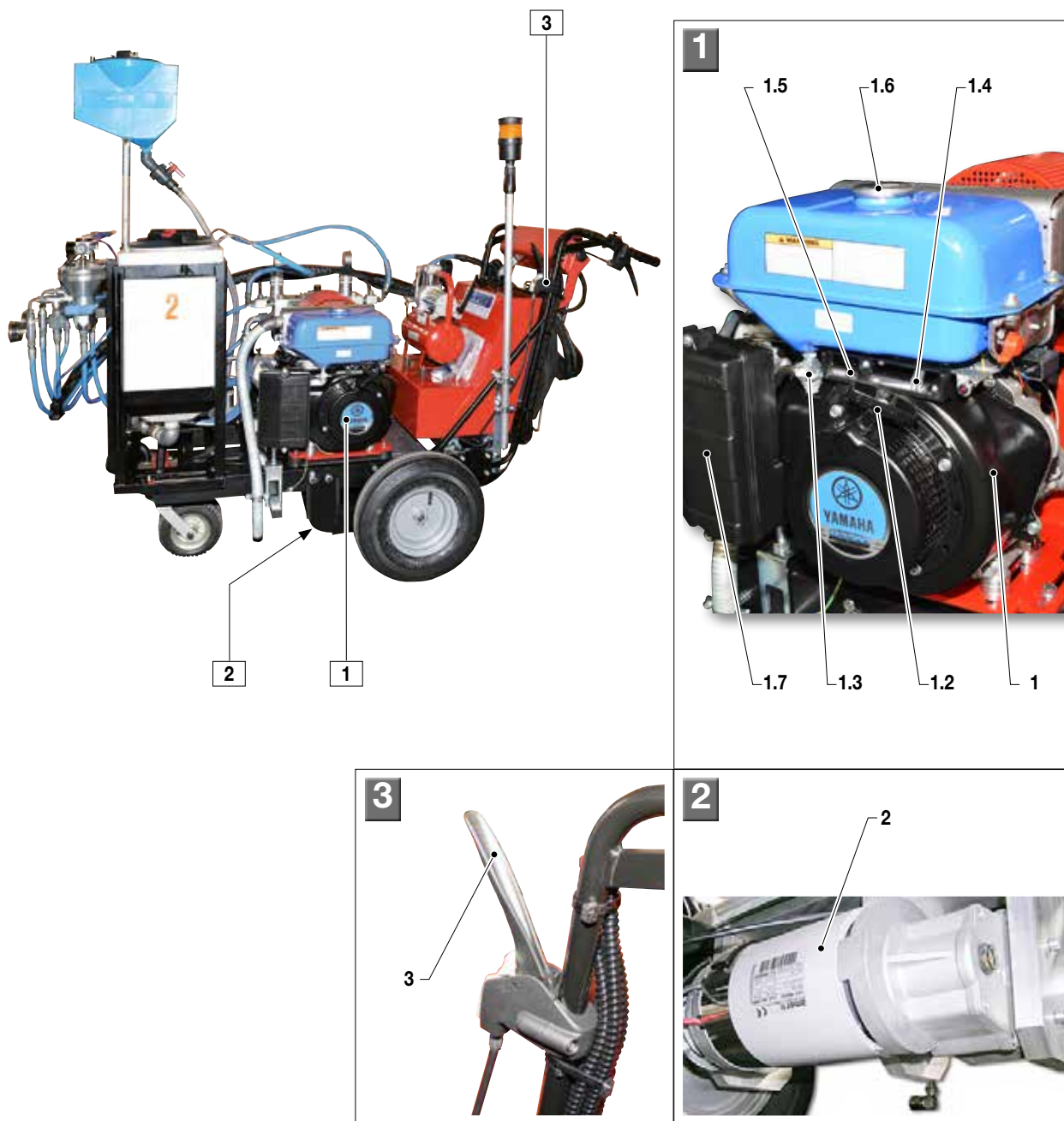

POS.	Description
1	Combustion engine
1.1	Cord pull-start ignition
1.2	ON/OFF switch combustion engine
1.3	ON/OFF Fuel tap
1.4	Motor rpm regulator
1.5	Air ON/OFF (choke)

POS.	Description
1.6	Fuel tap
1.7	Air filter
2	Electric motor for forward/reverse movement
3	Traction locking / releasing lever

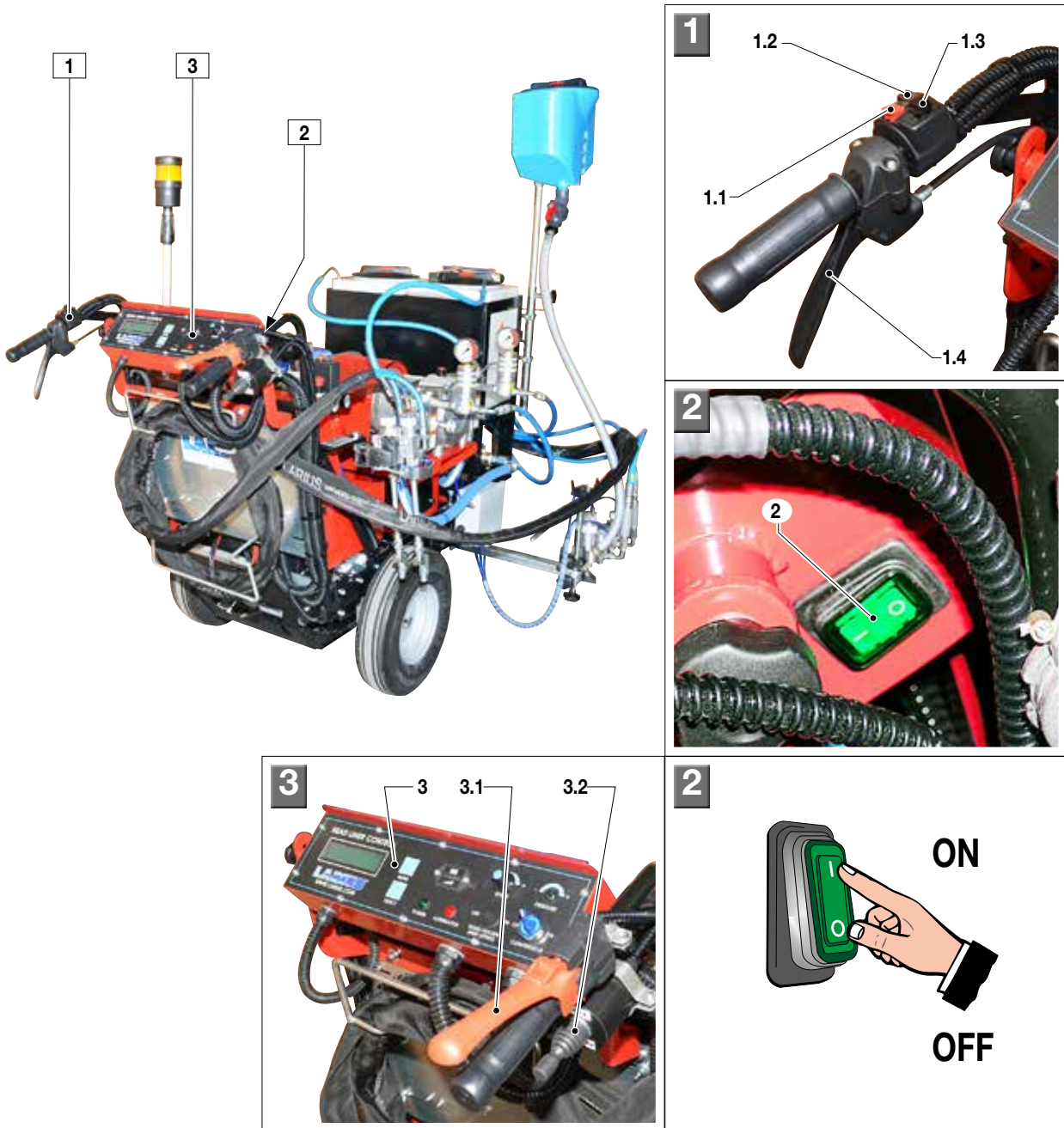

POS.	Description
1	Group
1.1	Manual spraying control switch
1.2	Flashing light switch (depending on the version)
1.3	Forward / Backward selector
1.4	Direction releasing lever

POS.	Description
2	ON/OFF panel Head Liner
3	Control Head Liner panel
3.1	Machine driving lever
3.2	Lever for automatic or manual line painting selection

D TRANSPORT AND UNPACKING

- The packed parts should be handled as indicated in the symbols and markings on the outside of the packing.
- Before installing the equipment, ensure that the area to be used is large enough for such purposes, is properly lit and has a clean, smooth floor surface.

The user is responsible for the operations of unloading and handling and should use the maximum care so as not to damage the individual parts or injure anyone.
To perform the unloading operation, use only qualified and trained personnel (truck and crane operators, etc.) and also suitable hoisting equipment for the weight of the installation or its parts. Follow carefully all the safety rules.
The personnel must be equipped with the necessary safety clothing.

- The manufacturer will not be responsible for the unloading operations and transport to the workplace of the machine.
- Check the packing is undamaged on receipt of the equipment. Unpack the machine and verify if there has been any damage due to transportation. In case of damage, call immediately **the manufacturer** and the Shipping Agent. All the notices about possible damage or anomalies must arrive timely within 8 days at least from the date of receipt of the plant through Registered Letter to the Shipping Agent and to **the manufacturer**.

The disposal of packaging materials is a customer's competence and must be performed in accordance with the regulations in force in the country where the plant is installed and used. It is nevertheless sound practice to recycle packaging materials in an environment-friendly manner as much as possible.

E SAFETY RULES

- THE EMPLOYER SHALL TRAIN ITS EMPLOYEES ABOUT ALL THOSE RISKS STEMMING FROM ACCIDENTS, ABOUT THE USE OF SAFETY DEVICES FOR THEIR OWN SAFETY AND ABOUT THE GENERAL RULES FOR ACCIDENT PREVENTION IN COMPLIANCE WITH INTERNATIONAL REGULATIONS AND WITH THE LAWS OF THE COUNTRY WHERE THE PLANT IS USED.

- THE BEHAVIOUR OF THE EMPLOYEES SHALL STRICTLY COMPLY WITH THE ACCIDENT PREVENTION AND ALSO ENVIRONMENTAL REGULATIONS IN FORCE IN THE COUNTRY WHERE THE PLANT IS INSTALLED AND USED.

Read carefully and entirely the following instructions before using the product. Please save these instructions in a safe place.

The unauthorised tampering/replacement of one or more parts composing the machine, the use of accessories, tools, expendable materials other than those recommended by the manufacturer can be a danger of accident.

The manufacturer will be relieved from tort and criminal liability.

- KEEP YOUR WORK PLACE CLEAN AND TIDY. DISORDER WHERE YOU ARE WORKING CREATES A POTENTIAL RISK OF ACCIDENTS.
- ALWAYS KEEP PROPER BALANCE AVOIDING UNUSUAL STANCE.
- BEFORE USING THE TOOL, ENSURE THERE ARE NOT DAMAGED PARTS AND THE MACHINE CAN WORK PROPERLY.
- ALWAYS FOLLOW THE INSTRUCTIONS ABOUT SAFETY AND THE REGULATIONS IN FORCE.
- KEEP THOSE WHO ARE NOT RESPONSIBLE FOR THE EQUIPMENT OUT OF THE WORK AREA..
- NEVER EXCEED THE MAXIMUM WORKING PRESSURE INDICATED.
- NEVER POINT THE SPRAY GUN AT YOURSELVES OR AT OTHER PEOPLE. THE CONTACT WITH THE CASTING CAN CAUSE SERIOUS INJURIES.
- IN CASE OF INJURIES CAUSED BY THE GUN CASTING, SEEK IMMEDIATE MEDICAL ADVICE SPECIFYING THE TYPE OF THE PRODUCT INJECTED. NEVER UNDERVALUE A WOUND CAUSED BY THE INJECTION OF A FLUID.
- ALWAYS DISCONNECT THE SUPPLY AND RELEASE THE PRESSURE IN THE CIRCUIT BEFORE PERFORMING ANY CHECK OR PART REPLACEMENT OF THE EQUIPMENT.
- NEVER MODIFY ANY PART IN THE EQUIPMENT. CHECK REGULARLY THE COMPONENTS OF THE SYSTEM. REPLACE THE PARTS DAMAGED OR WORN.
- TIGHTEN AND CHECK ALL THE FITTINGS FOR CONNECTION BETWEEN PUMP, FLEXIBLE HOSE AND SPRAY GUN BEFORE USING THE EQUIPMENT.
- ALWAYS USE THE FLEXIBLE HOSE SUPPLIED WITH STANDARD KIT. THE USE OF ANY ACCESSORIES OR TOOLING OTHER THAN THOSE RECOMMENDED IN THIS MANUAL, MAY CAUSE DAMAGE OR INJURE THE OPERATOR.
- THE FLUID CONTAINED IN THE FLEXIBLE HOSE CAN BE VERY DANGEROUS. HANDLE THE FLEXIBLE HOSE CAREFULLY. DO NOT PULL THE FLEXIBLE HOSE TO MOVE THE EQUIPMENT. NEVER USE A DAMAGED OR A REPAIRED FLEXIBLE HOSE.



 The high speed of the product in the hose can create static electricity through discharges and sparks. The pump is connected to the earth with a dragging chain. It is suggested to earth the equipment.



 The pump is earthed through the earth cable of the supply. The gun is earthed through the high pressure flexible hose. All the conductors near the work area must be earthed.



 The pump is earthed through the earth cable of the supply. The gun is earthed through the high pressure flexible hose. All the conductors near the work area must be earthed.

- NEVER SPRAY OVER FLAMMABLE PRODUCTS OR SOLVENTS IN CLOSED PLACES.
- NEVER USE THE TOOLING IN PRESENCE OF POTENTIALLY EXPLOSIVE GAS.



 Always check the product is compatible with the materials composing the equipment (pump, spray gun, flexible hose and accessories) with which it can come into contact. Never use paints or solvents containing halogen hydrocarbons (as the methylene chloride).



 If these products come into contact with aluminium parts can provoke dangerous chemical reactions with risk of corrosion and explosion.

 If these products come into contact with aluminium parts can provoke dangerous chemical reactions with risk of corrosion and explosion.



 IF THE PRODUCT TO BE USED IS TOXIC, AVOID INHALATION AND CONTACT BY USING PROTECTION GLOVES, GOGGLES AND PROPER FACE SHIELDS.

 IF THE PRODUCT TO BE USED IS TOXIC, AVOID INHALATION AND CONTACT BY USING PROTECTION GLOVES, GOGGLES AND PROPER FACE SHIELDS.

 IF THE PRODUCT TO BE USED IS TOXIC, AVOID INHALATION AND CONTACT BY USING PROTECTION GLOVES, GOGGLES AND PROPER FACE SHIELDS.

 TAKE PROPER SAFETY MEASURES FOR THE PROTECTION OF HEARING IN CASE OF WORK NEAR THE PLANT.

CONDITIONS OF GUARANTEE

 The conditions of guarantee do not apply in the following situations:

- improper washing and cleaning of components causing malfunction, wear or damage to the equipment or any of its parts;
- improper use of the equipment;
- use that does not conform with applicable national legislation;
- incorrect or faulty installation;
- modifications, interventions and maintenance that have not been authorised by the manufacturer;
- use of non-original spare parts or parts that do not correspond to the specific model;
- total or partial non-compliance with the instructions provided.

Engine safety precautions:

- Read the engine operator's manual annex.





 Never attempt to tamper with the calibre of instruments.

F SETTING-UP

CONNECTION OF THE GUNS

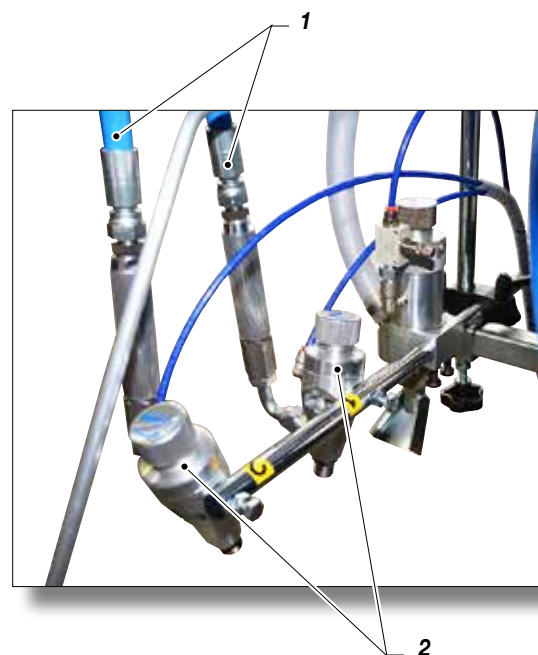
- Connect the high pressure hoses (1) to the flow regulator 3/18 and to the guns (2), taking care to fasten the connections tightly (*we recommend using two wrenches*). **NEVER** use any sealing products for threads on the fittings.
- It is recommended to use the hose provided with the standard kit. **NEVER** use a damaged or a repaired flexible hose.



CONNECTION OF THE MANUAL GUN

- Connect the high pressure flexible hose (3) to the flow regulator valves (4) and to the gun (5) tightening the fittings strongly (the use of two wrenches is suggested).

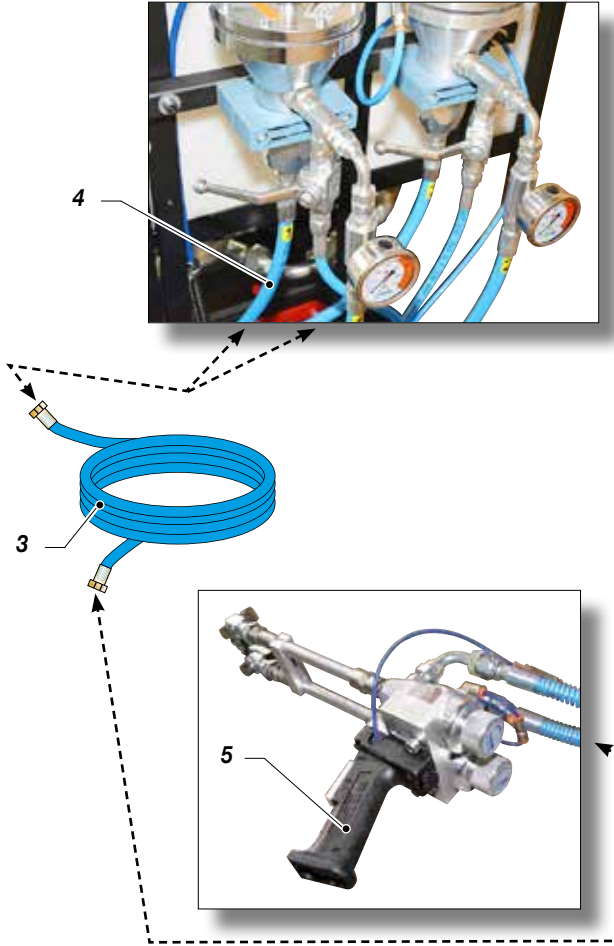

- Open the fuel tap (7) and position it to "ON" (I).

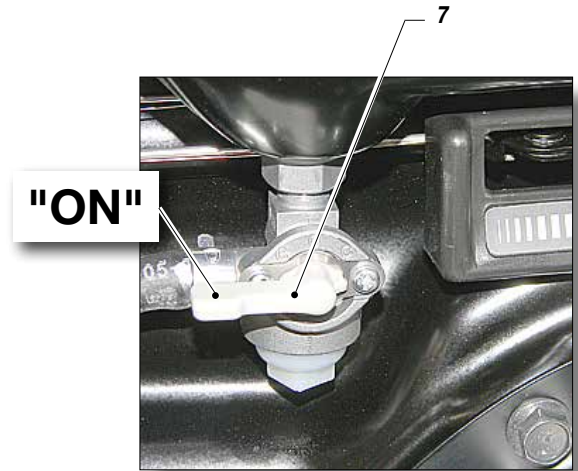

- Pull lever (8) for first start-up cold (position it to "I").

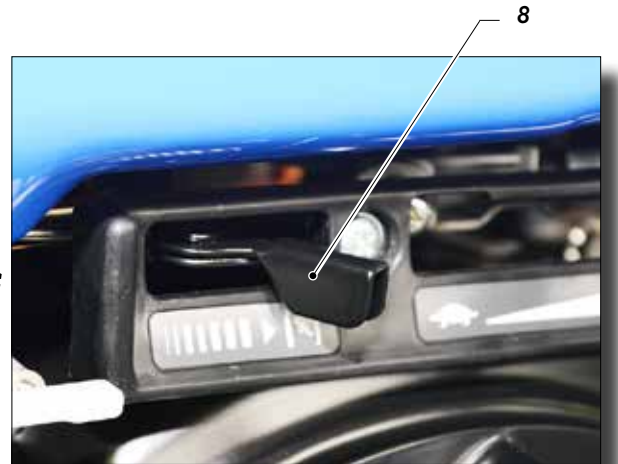

STARTING THE COMBUSTION ENGINE

To switch the internal combustion engine proceed as follows:

- Fill the fuel tank (6).

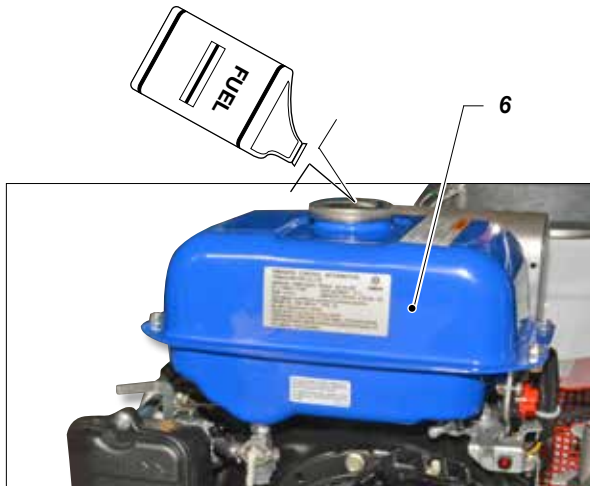

- Turn the equipment's switch (9) to ON (I).

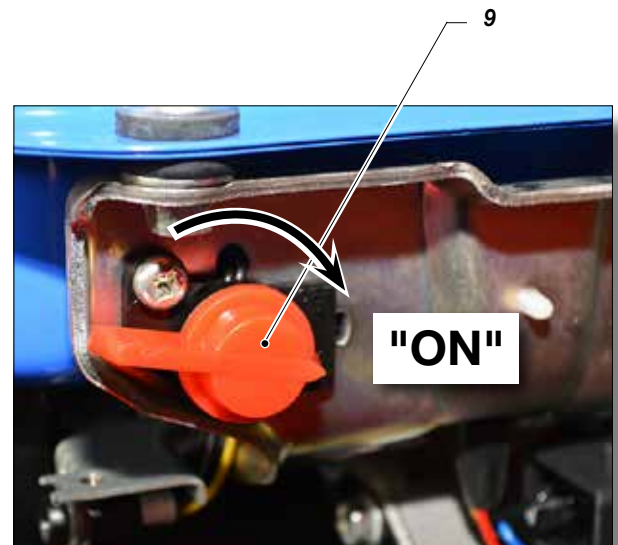

- Bring the accelerator lever (10) to about 1/2 of its run.

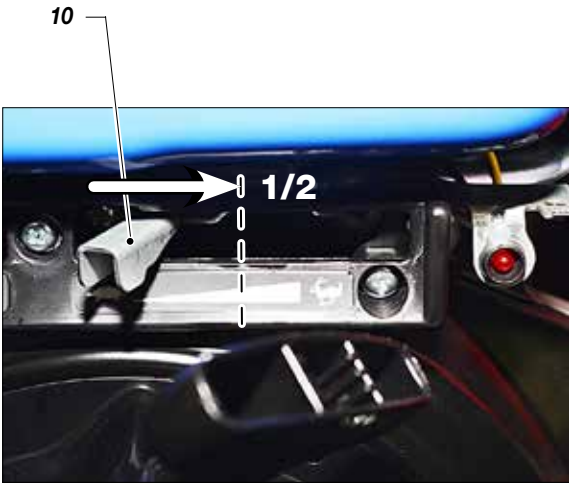

- Pull the rope to start (11).



WASHING OF THE NEW EQUIPMENT

- The equipment has already been adjusted at our factory with light mineral oil left inside the pumping group as protection. Therefore, wash with thinner before sucking the product.
- Fill the product tank with washing liquid.
- Ensure the guns (2-5) are without nozzle.

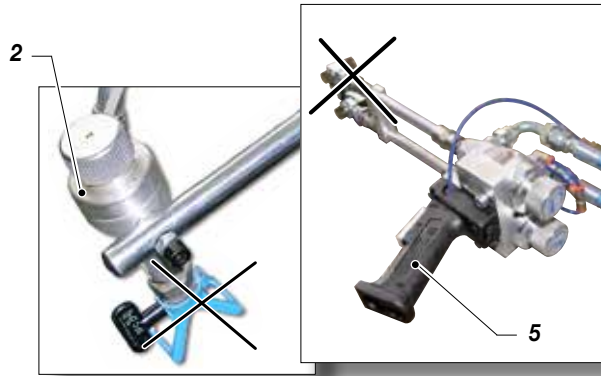

- Open the product output taps (12).

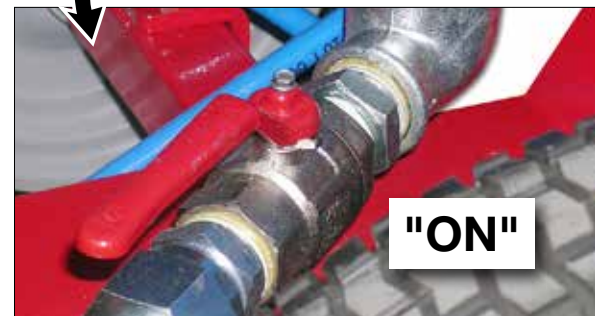
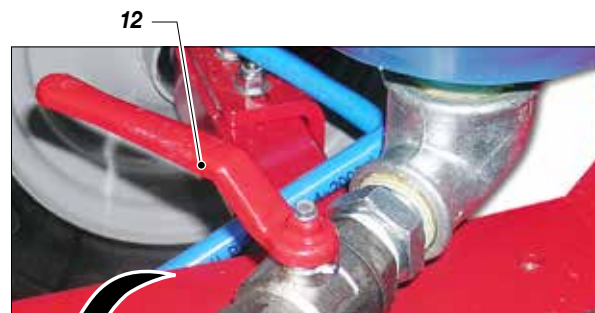

- Start the combustion engine following the indications provided in the chapter "STARTING COMBUSTION ENGINE".
- Turn the switch (13) to ON (I) in order to enable the control Head Liner panel.

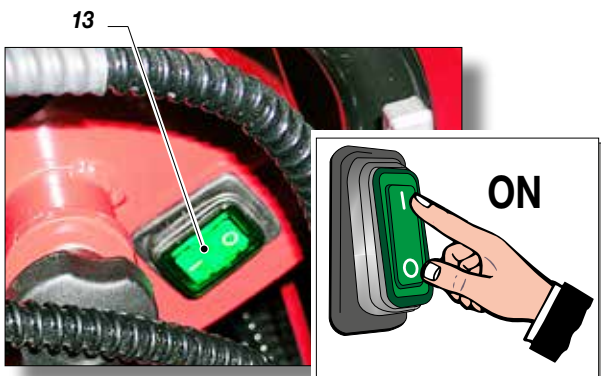

- Slightly turn pressure regulating knob (14) clockwise so that the machine idles.



14

- Open the re-circulation valve (15a) and (15b).
- Visually check that the washing liquid starts to re-circulate within the tank (16).
- Close the re-circulation valve (15a) and (15b).
- Open the tap (17) of the manual gun.

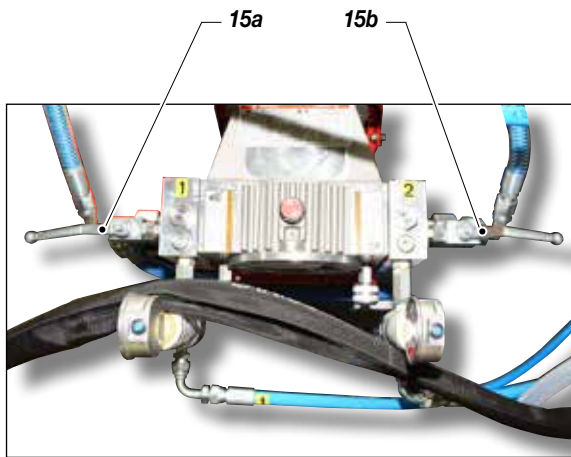

16

- Point the manual gun (15) towards a collecting container (16) keeping the trigger lever pressed (so as to drain the oil inside) till a clean solvent comes out. Now, release the lever.

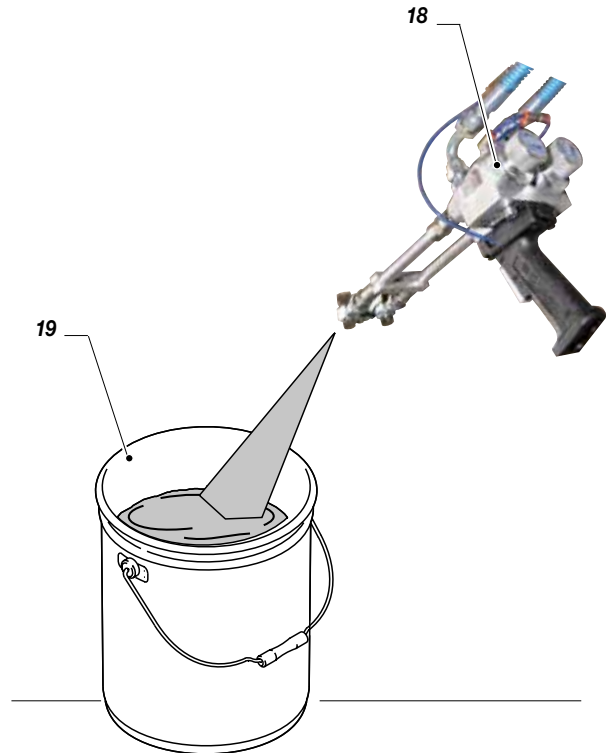

- Close the tap (17) of the manual gun.

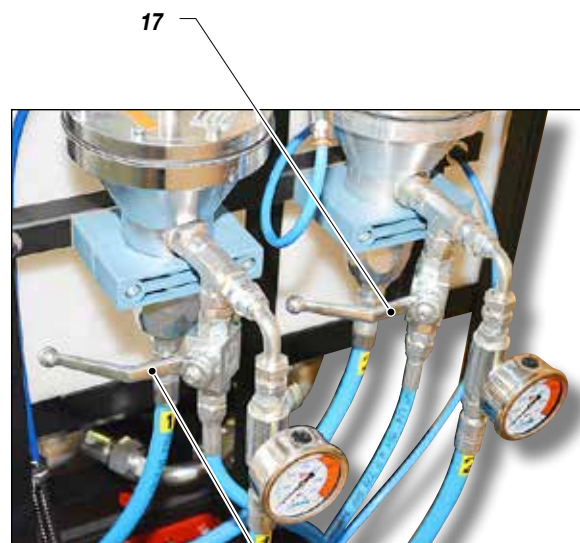

17

- Perform the same operation for the automatic spray guns as well (see *Head Liner control board instructions*).
- Remove any solvent remaining within the tubes by activating the manual and automatic guns.
- As soon as the pump begins to idle, turn the handle (14) to minimum to stop the system.



Absolutely avoid spraying solvents in closed environments. It is also recommended to keep the spray gun away from the pump in order to prevent vapours from coming into contact with the electrical motor.

- Stop the internal combustion engine.
- At this point the machine is ready. If water-based paints are to be used, after the washing with solvent, it is recommended to wash the tank again with soap and water, then rinse with clean water (*repeating the previously described procedures*).
- Insert the manual gun trigger lock and fix the nozzle.
- Insert the automatic guns trigger lock and fix the nozzles.

PREPARATION OF THE PAINT

- Make sure the product is suitable to be used with a spray gun.
- Mix and filter the product before using it. For filtration use **CLOSE-MESH** (ref. 214) and **LARGE-MESH** (ref. 215) LARIUS METEX braids.



Make sure the product to be used is compatible with the materials employed for manufacturing the equipment (*stainless steel and aluminium*). For this purpose, please contact the supplier of the product.

- Fill the tank (16) with the paint.

Never use products containing halogen hydrocarbons (as *methylene chloride*). If these products come into contact with aluminium parts of the equipment can provoke dangerous chemical reactions with risk of explosion.

G OPERATION

SETUP PROCEDURE

- Use the equipment only after performing all the **SETTING UP** operations described in the previous pages.
- Make sure that all the levers are in the **"RELEASE"** position, that is nothing is engaged.
- Check that the automatic lever (1) is in its "0" position.

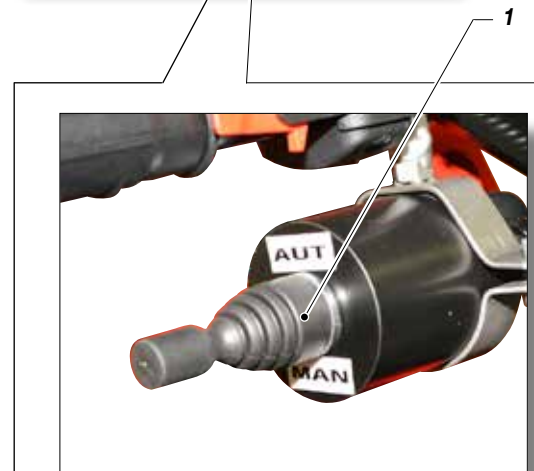

- Check that there is enough unleaded petrol. Turn fuel (2) knob to "ON".



- Turn the equipment knob (3) on "ON".

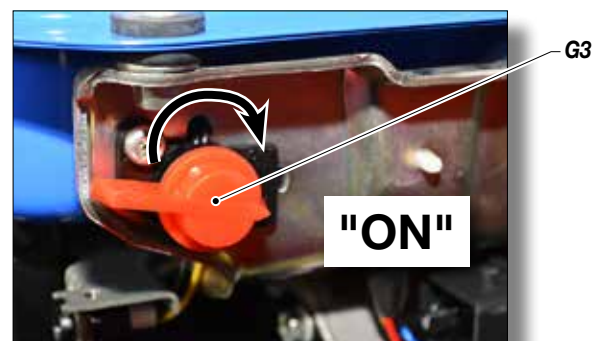

- Start the combustion engine following the indications provided in the chapter “STARTING COMBUSTION ENGINE”.
- Open the re-circulation valve (4a) and (4b).
- Turn slightly pressure regulating knob (5) clockwise so that the machine idles.
- Visually check that the product starts to re-circulate within the tank.
- Close the re-circulation valve (4a) and (4b).
- Open the tap (6) (if necessary only for painting with the manual gun).
- Turn the pressure adjustment handle (5) to the suitable operation value.

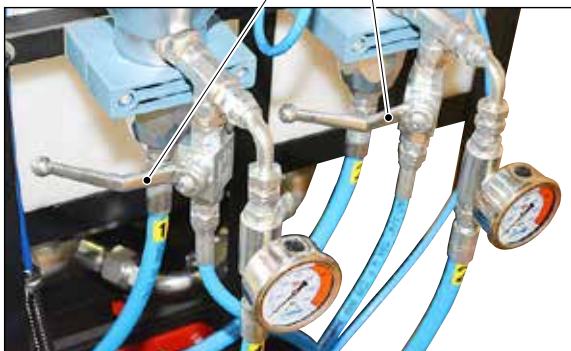
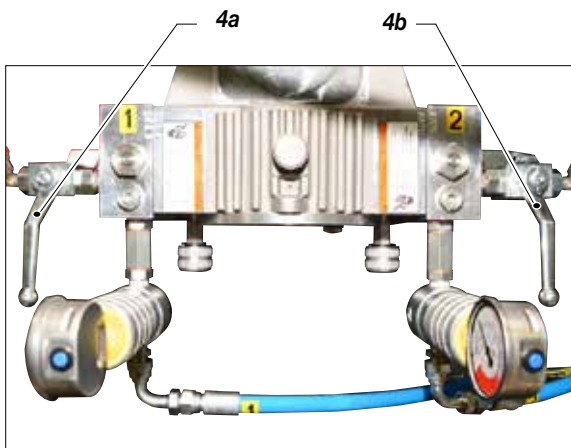

- At this point the machine will continue to suck the product till the flexible hose is full, up to the gun, and then it will

stop automatically once reached the preset pressure.

- Activate the compressor (8) (adjust the compressor pressure to 6 bar).

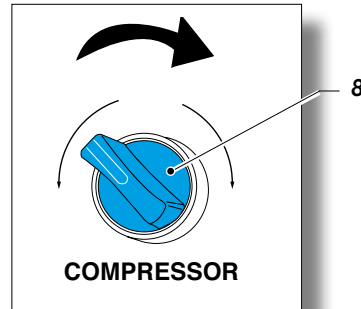

- Release the electric brake using the lever (9), in order to be able to move the machine more easily and accurately.

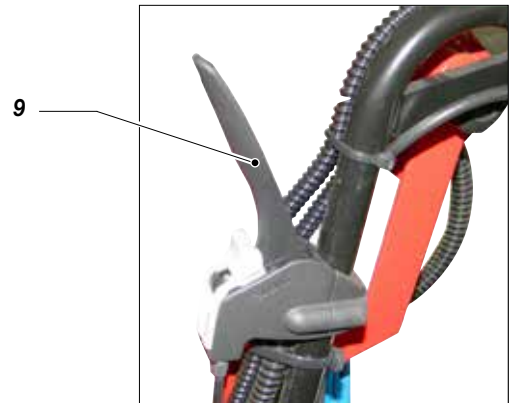

ADJUSTING THE INTERNAL COMBUSTION ENGINE SPEED

- Gently move the motor acceleration lever (10) to increase or decrease the speed of the pump. During the painting operation it is normally recommended to maintain the position of the accelerator lever (10) at about 3/4 of its run.

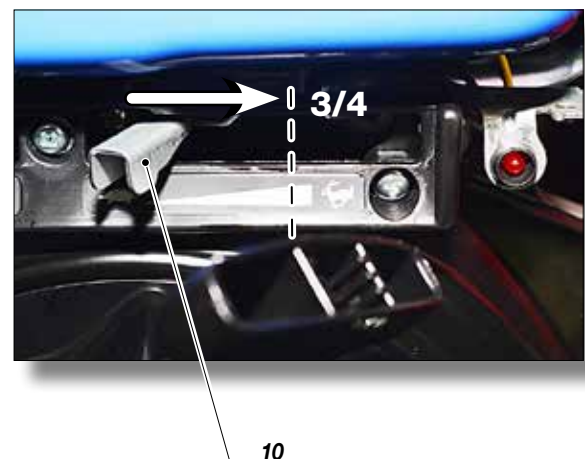

H PAINTING OPERATIONS

- Turn the pressure adjusting knob (1) and (2) to the suitable operation value ("+")



- It is possible to switch the control lever (3) placed on the right handle, on position "AUT" (AUTOMATIC) or on position "MAN" (MANUAL) to set the operation conditions of the automatic guns.
(See the "control bridge use" section for programming).



- The machine is outfitted with a manual (4) gun with a tube (5) to perform roadside writings with paint templates. The gun is situated under the control handles placed on the special tube winder.
- In order to use the manual spray gun, open the valve (6) located at the delivery filter's outlet.

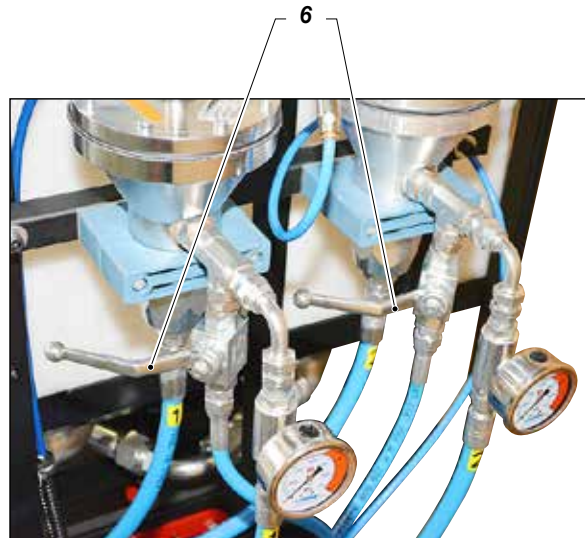
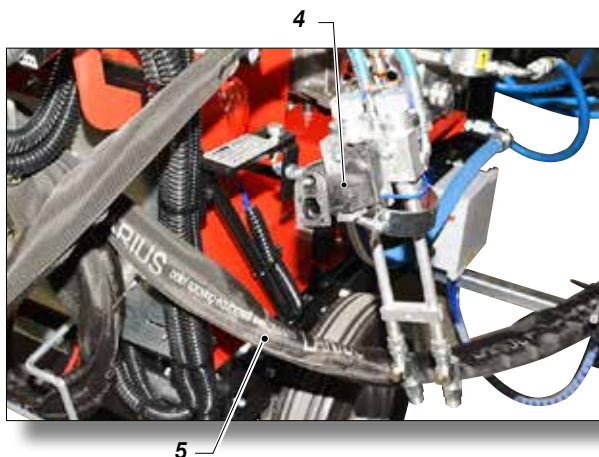

- If operation is required upon a long rectilinear section, the lever (7) must be placed in its position. A spring-action mechanical stopper will automatically block the front wheel (8) in its straight position, thereby ensuring a straight trajectory for the operator.



- Press the advancement lever (9) and begin to work based on the set cycle by activating the gun control lever "AUT" or "MAN" (3).

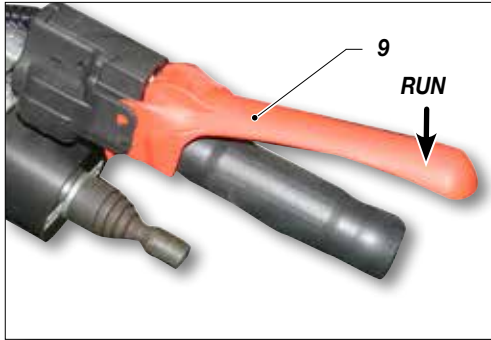

SPRAYING JET ADJUSTMENT

- Slowly turn clockwise the pressure control knob (10) to reach the pressure value able to grant a good atomization of the product.
- An irregular and marked spray on the sides indicates a low working pressure. On the contrary, a too high pressure causes a high fog ("overspray") and waste of product.
- In order to avoid excess paint thickness, do not spray if not simultaneously advancing with the machine.

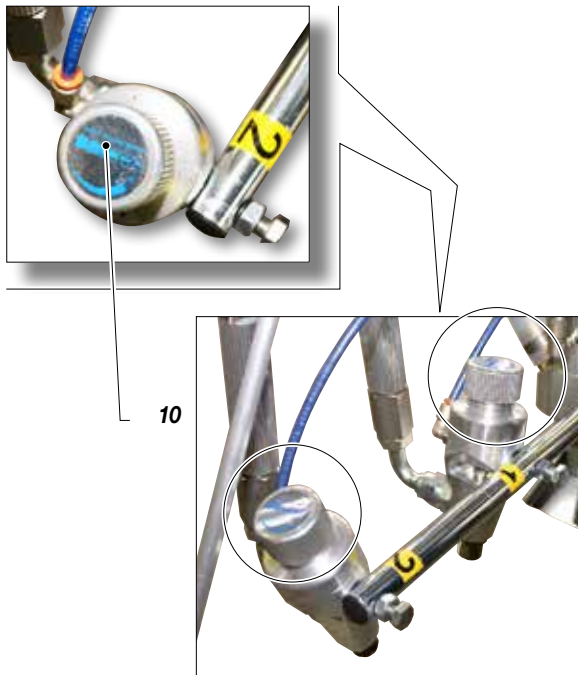

Warning: Recirculation safety valve: when working at the maximum pressure available, the release of the gun trigger may cause sudden increases of pressure. In this case, the recirculation safety valve opens automatically discharging part of the product from the recirculating tube. Then it closes so as to restore the previous working conditions.

Warning: After having used the equipment, follow all the procedures for decompression and cleaning indicated in the manual. At the end of the work, switch the levers into the resting position.

I CATADIOPTIC PEARLS DISTRIBUTING KIT

DESCRIPTION OF THE EQUIPMENT

With the new distribution system of reflecting pearls, the "VIKING LINER PLUS" unit can produce a more visible and therefore safer roadway indication, even in the worst weather conditions. The pearlized distribution kit is composed of a drop tank with two openings, two rubber tubes that carry the reflecting pearls to the dispensers.

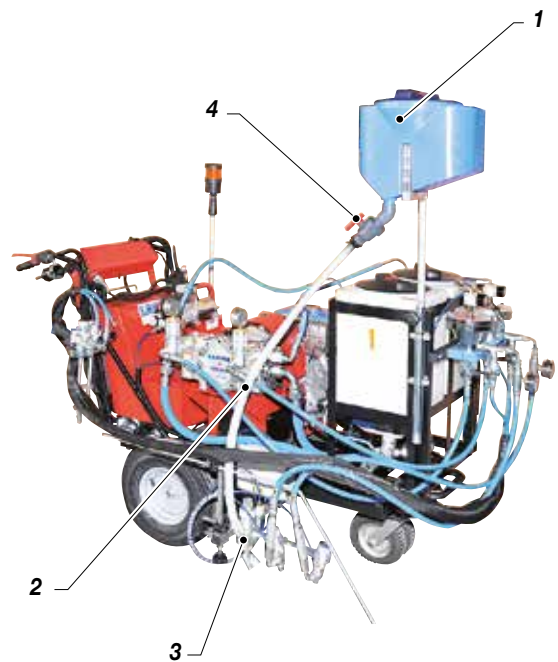

POS.	Description
1	Drop tank
2	Filling tubes
3	Dispensers
4	Catadioptric material distributing valve

J ADJUSTMENTS

ADJUSTING GUNS POSITION

The guns (4) are mounted on suitable sliding arms (5), (6), (7), (8). This allows the correct positioning of the guns according to working requirements.

The movements are indicated by the arrows (a), (b), (c), (d). In order to allow the shifting of the guns on the relevant arms, it is necessary to release the handles (9), (10), (11), (12) and the screws (13), (14).

Once the adjustment is completed, provide to duly tighten handles and screws.

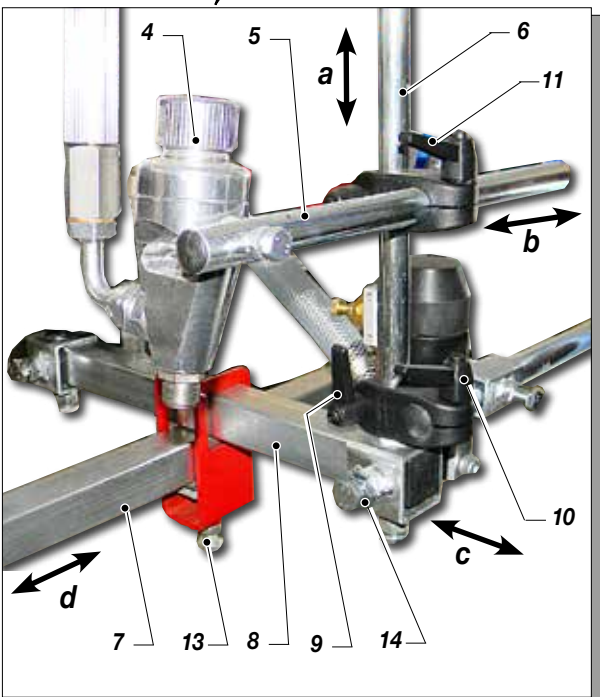

ADJUSTING THE REFLECTING PEARLS DISTRIBUTION UNIT

To set the position of the reflecting pearls distributors (15) it is necessary to adjust the screws (16).

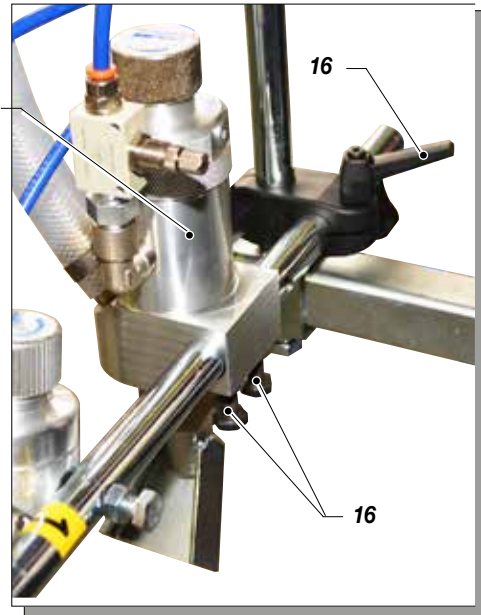

ADJUSTING THE PNEUMATIC SYSTEM PRESSURE



Before adjusting the pressure, start the compressor using the button (9).

In order to regulate the pressure in the pneumatic system, turn the knob (10) clockwise (+) to increase the pressure and counterclockwise (-) to reduce it.

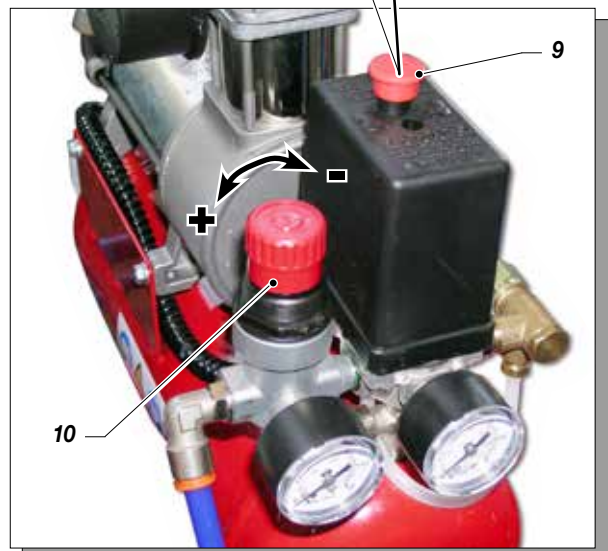
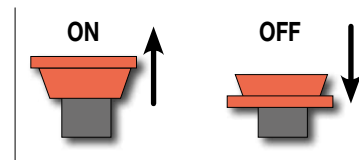

K CLEANING AT THE END OF WORK

- Reduce pressure to the minimum [turn counterclockwise the pressure control knob (1)].



- Press the switch (2) placed on the box of the electric motor to its OFF (0) position to stop the motor pump.

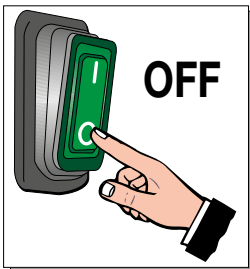
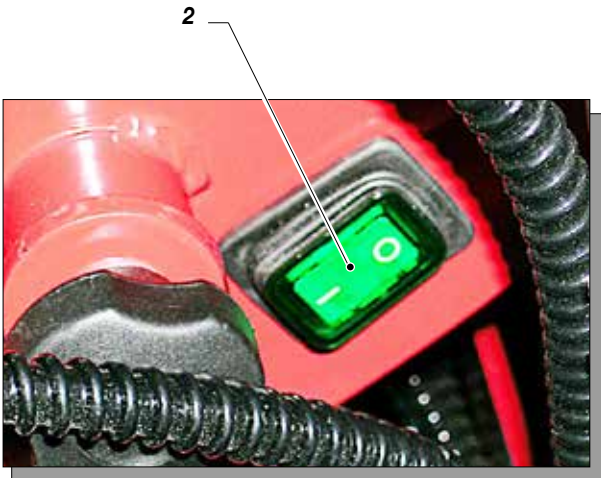

- Open the recirculation safety valve (3a) and (3b) to discharge the pressure in the circuit.

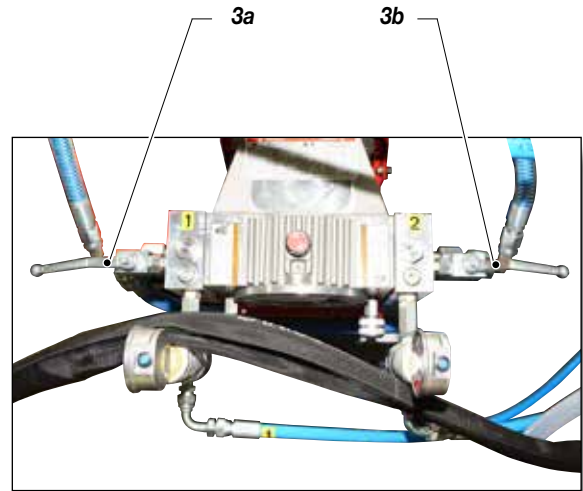

- Lift the suction pipe and replace the product tank with that of the solvent (make sure it is compatible with the product being used).
- Unscrew the gun nozzle (do not forget to clean it with solvent or water if you used hydrosoluble paints).
- Press the ON (I) switch and slightly turn the pressure control knob (1) clockwise so as the machine works until the connection to the engine is triggered.



- Make sure the solvent recycles from the recirculation tube.
- Point the gun towards the product collection tank and, keeping the trigger pressed, discharge the remaining product till a clean solvent comes out. Now, release the trigger.

- Lift again the suction pipe and remove the solvent tank.
- Point the manual gun (4) into a container (5), drain the residual paint and wait for the washing fluid to come out clean.

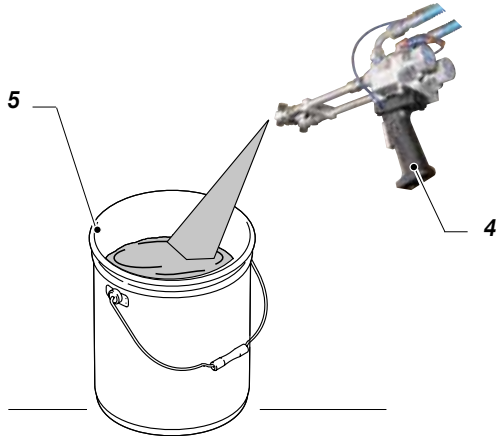

- As the pump starts idling, reduce pressure to the minimum (*turn counterclockwise the pressure control knob (1)*), press the OFF (0) switch to disengage the pump from the engine and stop the engine.
- Perform the washing of the guns.
- In case of long prolonged downtime, we recommend you to suck and to leave light mineral oil inside the pumping group and the flexible hose.
- From the control panel, set the **MENU 1** operation of the right and left guns simultaneously.
- Move the control lever to position "MAN" and drain any residual paint. Wait for the cleaning liquid to come through clean.
- Remove all clearing liquid from the tank and turn the machine off.
- Turn the pressure adjustment knob (1) to minimum (*pump stopped*).



Follow the washing procedure before using the equipment again.

L GENERAL MAINTENANCE



Discharge the pressure in the pump unit (*open the discharge valve*) before carrying out any maintenance operation.

DAILY

- Clean the filters;
- Clean the nozzles;
- Clean all the paint circuit with a specific product;
- Check the fuel motor (*see maintenance table*).

PERIODICALLY

- Clean the movable parts from the paint deposits (*clutch traction, spray guns, etc.*);
- Check the gun cables tightening, the wheel block and the traction;
- Check that the tubes and all the fittings are correctly tightened.

M ROUTINE MAINTENANCE

TOP UP HYDRAULIC OIL

With each start up, check the hydraulic oil level by looking through the gauge on the side of the hydraulic body. If necessary, use to top up the level:

AGIP DICREA 150 type hidraulic oil

RELEASE THE SUCTION VALVE

In case of pump failure, release the suction valve fitted on the head of the pump in the following way:

- Remove the suction hose fitting and release the valve by inserting a rigid rod (1) with a diameter lower than 15 mm.

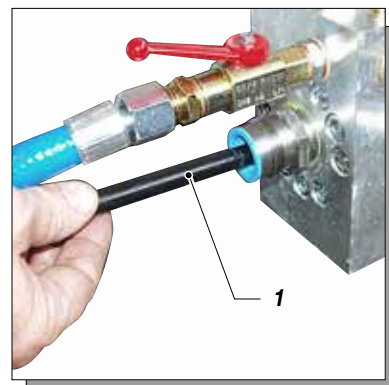

CLEANING THE COMPRESSION VALVE

When the compression valve must be removed, clean it with specific solvents according to the type of paint used and refit all parts by inverting the disassembly order.

REPLACING THE HYDRAULIC OIL

After operating for 100 hours, replace the oil in the pump;

- Discharge the waste oil through the *hydraulic filter* fitted at the bottom of the pump casing.
- Clean and, if necessary, replace the worn seals.
- Replace the filter in its seat by screwing it tightly.
- Fill the pump with the recommended oil until it reaches the maximum level.

AGIP DICREA 150 type hidraulic oil

- Then, replace the oil every 250 hours.

Oil max level



MOTOR OIL CHECK



Always check that there is oil in the motor.

Every 100 hours check the oil level through the dedicated oil plugs on the base of the engine. Refill the oil level if necessary.

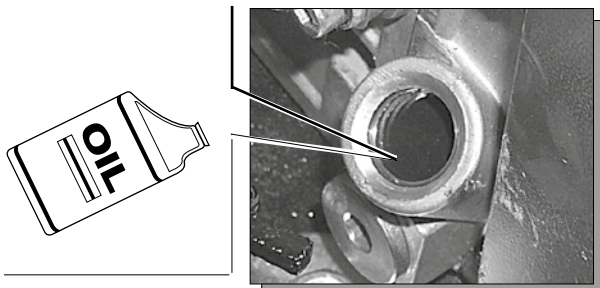

DESCRIPTION OF CONTROLS

1) Directional lever

Pull on the lever to release the linear drive lock (a) and allow the machine to perform curved line tracts.

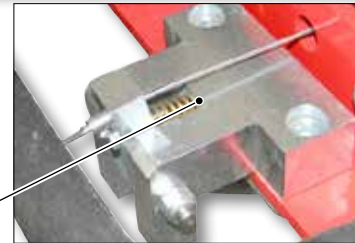

2) Advancement

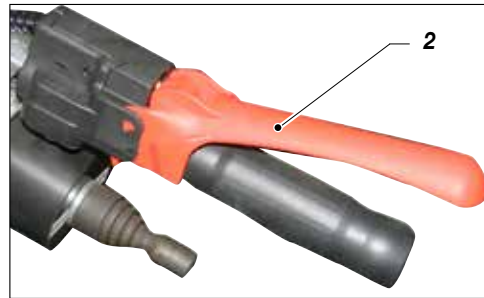

3) Accelerator

It gradually sets the number of revolutions of the internal combustion engine.

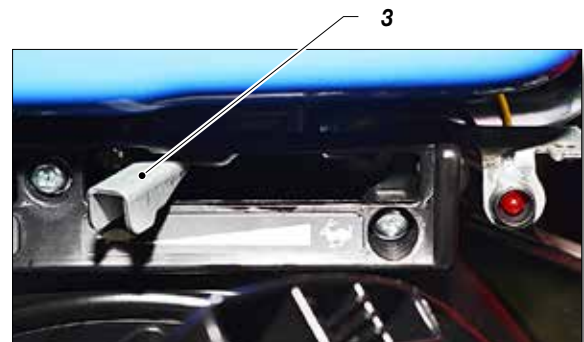

- 4) **Direction selector**
It allows the user to select the machine advancement direction; if pressed, it stops the machine movement.
- 5) **Electric brake release**
When pressed, it allows the machine to be pushed in the event of electrical failure or lockage.
- 6) **Light switch**
It activates/deactivates the frontal spotlight (if installed).
- 7) **Spraying**
By pressing it, the manual spraying is enabled.
- 8) **indicator**
It displays the battery charge status.
- 9) **Speed regulation handle**
It allows the user to gradually regulate the machine's advancement speed.
- 10) **Blue light selector**
It activates the oil cooling fan.
- 11) **Green indicator light**
When on, it indicates that the machine is ready for operation
- 12) **Alternator**
When the red indicator is on, it indicates a failure of the alternator employed for charging the batteries.

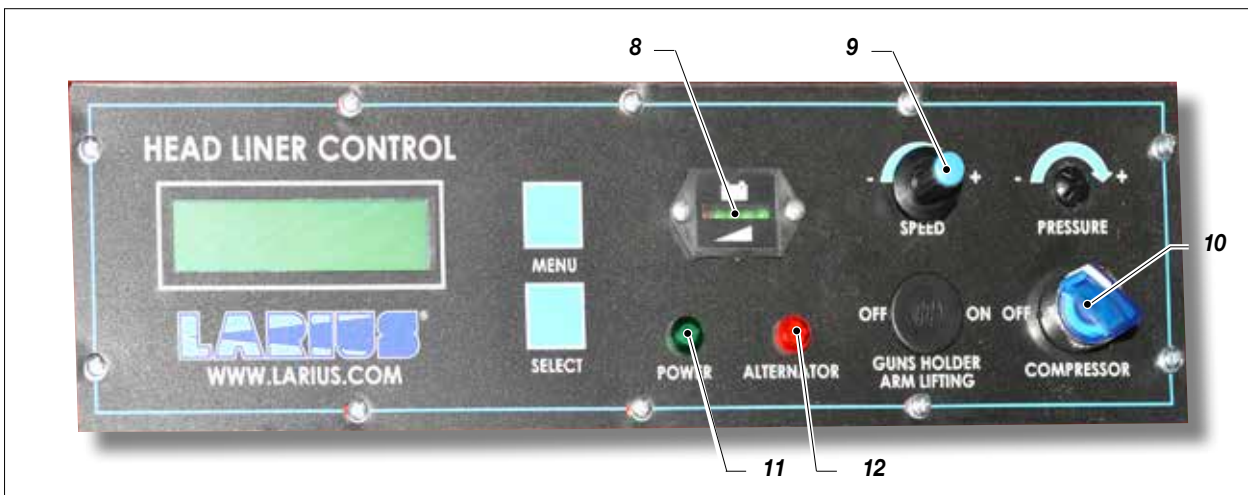
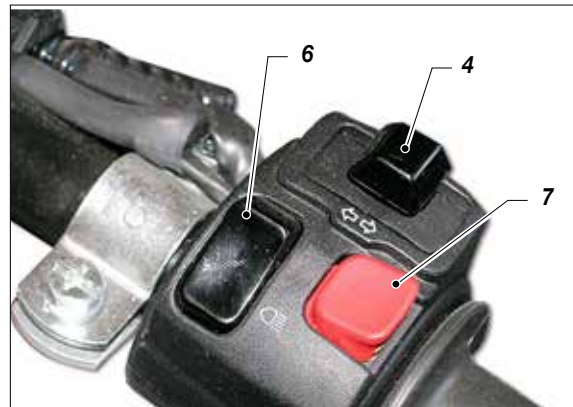
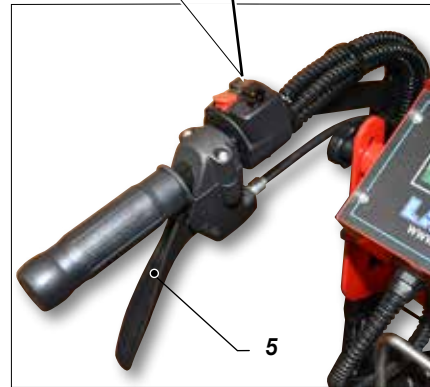
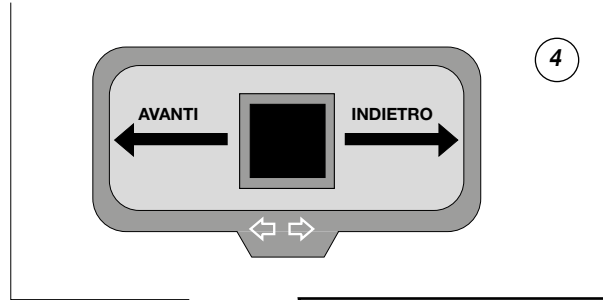

TROUBLESHOOTING

Problem	Cause	Solution
<ul style="list-style-type: none"> • Engine won't start • WARNING : <i>For further solutions to engine problems please see the enclosed "Lombardini" instruction manual.</i> 	<ul style="list-style-type: none"> • The fuel manifold is closed; • Engine is out of gas; • Cold engine; • Spark plug cable is disconnected or damaged; 	<ul style="list-style-type: none"> • Switch the fuel manifold to "Open" position; • Refill gas tank; • Switch the Start lever to MAX position; • Connect or replace the cable;
<ul style="list-style-type: none"> • The equipment does not start 	<ul style="list-style-type: none"> • On/Off switch disconnected; • Breakdown of pressure transmitter; • Breakdown of motor electric control box; • The line of material coming out of the pump is already under pressure; • The product is solidified inside the pump; 	<ul style="list-style-type: none"> • Ensure the On/Off switch is on the "on" position and turn clockwise the pressure control knob; • Verify and replace it, if necessary; • Verify and replace it, if necessary; • Open the drain valve to release pressure in the circuit; • Open the drain valve to release pressure in the circuit and stop the machine. Disassemble the pumping group and the pressure transmitter and clean;
<ul style="list-style-type: none"> • The equipment does not suck the product 	<ul style="list-style-type: none"> • Suction filter clogged; • Suction filter too fine; • The equipment sucks air; 	<ul style="list-style-type: none"> • Clean or replace it; • Replace it with a larger-mesh filter (<i>with very dense products, remove the filter</i>); • Check the suction pipe;
<ul style="list-style-type: none"> • The equipment sucks but it does not reach the pressure desired 	<ul style="list-style-type: none"> • Lack of product; • The equipment sucks air; • The drain valve is open; • Suction or delivery valve dirty; 	<ul style="list-style-type: none"> • Add the product; • Check the suction pipe; • Close the drain valve; • Disassemble the pumping group;
<ul style="list-style-type: none"> • When pressing the trigger, the pressure lowers considerably 	<ul style="list-style-type: none"> • Nozzle too big or worn; • The product is too dense; • The filter of the gun-butt is too fine; 	<ul style="list-style-type: none"> • Replace it with a smaller one; • Dilute the product, if possible; • Replace it with a larger-mesh filter;
<ul style="list-style-type: none"> • The pressure is normal but the product is not atomized 	<ul style="list-style-type: none"> • The nozzle is partially clogged; • The product is too dense; • The filter of the gun-butt is too fine; 	<ul style="list-style-type: none"> • Clean or replace it; • Dilute the product, if possible; • Replace it with a larger-mesh filter;
<ul style="list-style-type: none"> • The atomization is imperfect 	<ul style="list-style-type: none"> • The nozzle is worn; 	<ul style="list-style-type: none"> • Replace it;
<ul style="list-style-type: none"> • When releasing the trigger of the gun, the equipment does not stop 	<ul style="list-style-type: none"> • Suction or delivery valve dirty; • Drain valve defective; 	<ul style="list-style-type: none"> • Disassemble the pumping group and clean; • Verify and replace it, if necessary;

P CORRECT PROCEDURE OF DECOMPRESSION

MANUAL GUN

- Push the OFF button (1) switching the machine off.



- Place under the gun the paint collecting tank.
- Operate the manual gun to discharge the pressure.

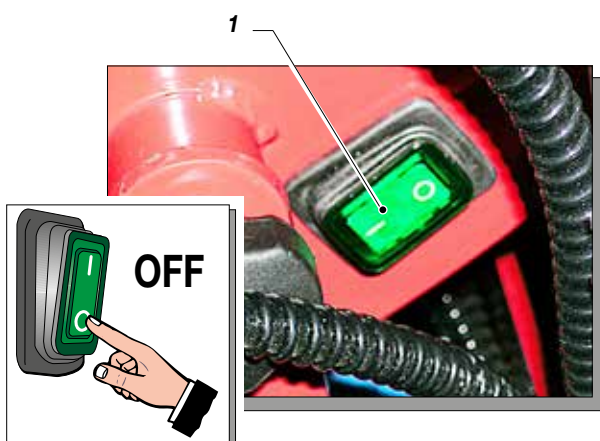

AUTOMATIC GUN

- Press the switch (2) to spray the product and discharge the residual pressure from the automatic guns.
- Turn the levers (3) and (4) to release residual pressure.

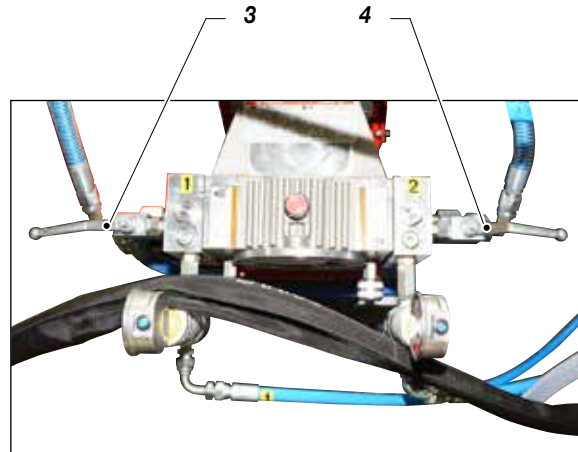

If the equipment is still under pressure after performing the operations above described because of the nozzle or the flexible hose clogged, proceed as follows:

- Loosen very slowly the gun nozzle.
- Release the safety clamp.
- Point the gun towards the collecting container of the product and press the trigger to release pressure.
- Loosen very slowly the connection fitting from the flexible hose to the gun.
- Clean or replace the flexible hose and the nozzle.



SPARE PARTS

R COMPLETE COLOUR BODY
Page 29

S COMPLETE HYDRAULIC BODY
Page 30

U CARTER
Page 34

T COMPLETE PUMP MOTOR BODY
Page 32

W FLOW REGULATORS
Page 36

Diagram of the Viking Liner Plus 2K machine with callouts for parts R, S, U, T, and W. The machine is shown from a side-rear perspective, highlighting the engine, pump, and various hoses and tanks.

X TANKS
Page 36

V ALTERNATOR
Page 35

Y LEVERISMI DI COMANDO
Page 37

Z SPARE PARTS
Page 38

Diagram of the Viking Liner Plus 2K machine with callouts for parts X, V, Y, and Z. The machine is shown from a side-front perspective, highlighting the engine, pump, and various hoses and tanks.

EXPLODED VIEW GUN LA 95 RIF. 23340/4

WARNING: Always indicate code and quantity for each part required.

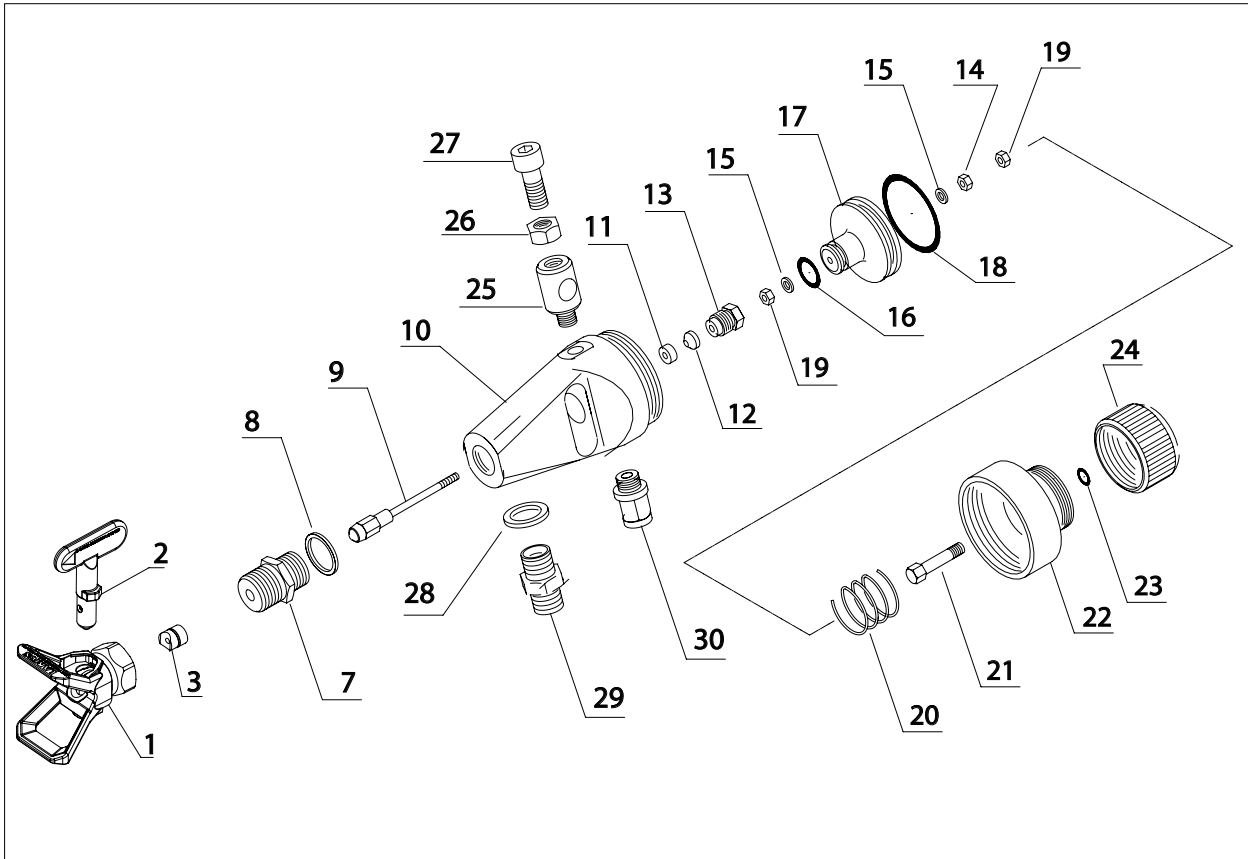

Pos.	Code	Description	Q.ty	Pos.	Code	Description	Q.ty
1	18270	Super Fast Clean body	1	19	11027	Self-blocking nut	2
2	See table*	Super Fast Clean	1	20	11108	Spring	1
3	18280	Super Fast Clean gaskets	1	21	11715	Screw	1
7	11004	Sleeve	1	22	11716	Back tap	1
8	33007	Washer	1	23	33013/7	O-ring	1
9	11705	Punch	1	24	11717	Adjusting knob	1
10	11711	Gun body	1	25	11718	Female coupling	1
11	11712	Gaskets stuffing ring	1		11720	Male coupling	1
12	11114	Gasket	1	26	52017	Nut	1
13	11713	Gaskets stuffing screw	1	27	34008	Screw	1
14	900025	M3 nut	1	28	33012	Washer	1
15	11714	Washer	2	29	3289	Nipple	1
16	32015/3	O-ring	1	30	11719	Cylindric fitting	1
17	11721	Piston	1	31	15002	Nozzle fitting	1
18	11105	O-ring	1				

R COMPLETE COLOUR BODY

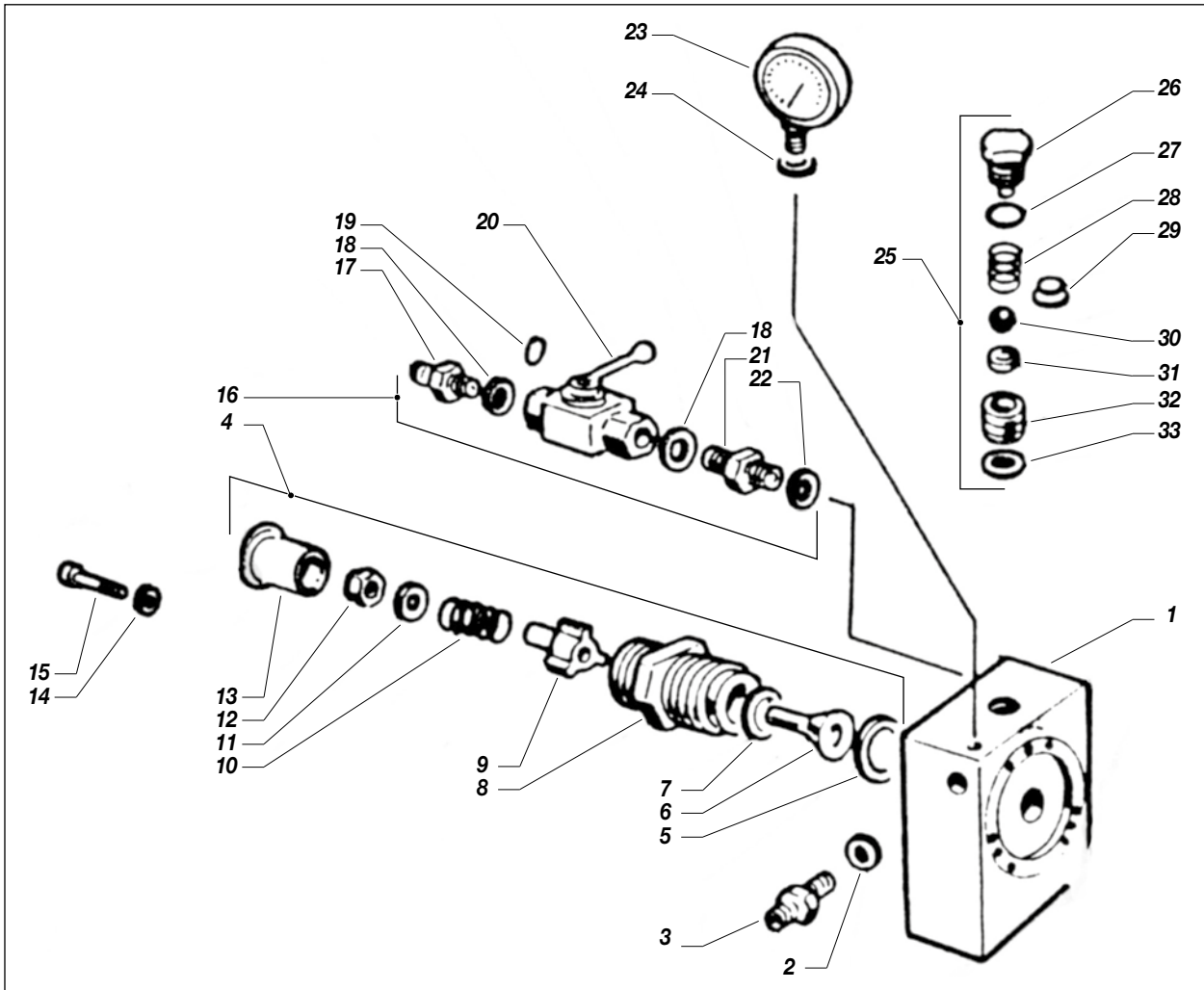

Pos	Code	Description	Pos	Code	Description
	33000	Complete colour body	17	33015	Nipple
1	33001DX	Right colour body casting	18	33012	1/4" copper washer
1	33001	Left colour body casting	19	33013/3	O ring
2	33007	Ø16 copper washer	20	33013	Return tap
3	33006	High pressure hose fitting	21	33011	3/8"x1/4" nipple
4	33017	Complete suction valve	22	33010	3/8" copper washer
5	33018	Gasket	23	33008	Pressure gauge
6	33019	Complete spear valve	24	33009	Pressure gauge gasket
7	33020/1	Spear valve seat	25	33033	Complete drain valve
8	33020	Valve body	26	33032	Sealing plug
9	33021	Spear valve guide	27	33031	Copper seal
10	33022	Spring	28	53006	Spring
11	33023	Ø6,3 washer	29	33029	Spring seat
12	33024	Self-locking nut	30	33028	Ø11 ball
13	96099	Inlet liner	31	33027/2	Ball seat
14	33005	Ø10 SCHNORR washer	32	33027/1	Ball seat fitting
15	33004	10x55 TCE screw	33	33026	Gasket
16	33016	Complete return tap			

S COMPLETE HYDRAULIC BODY

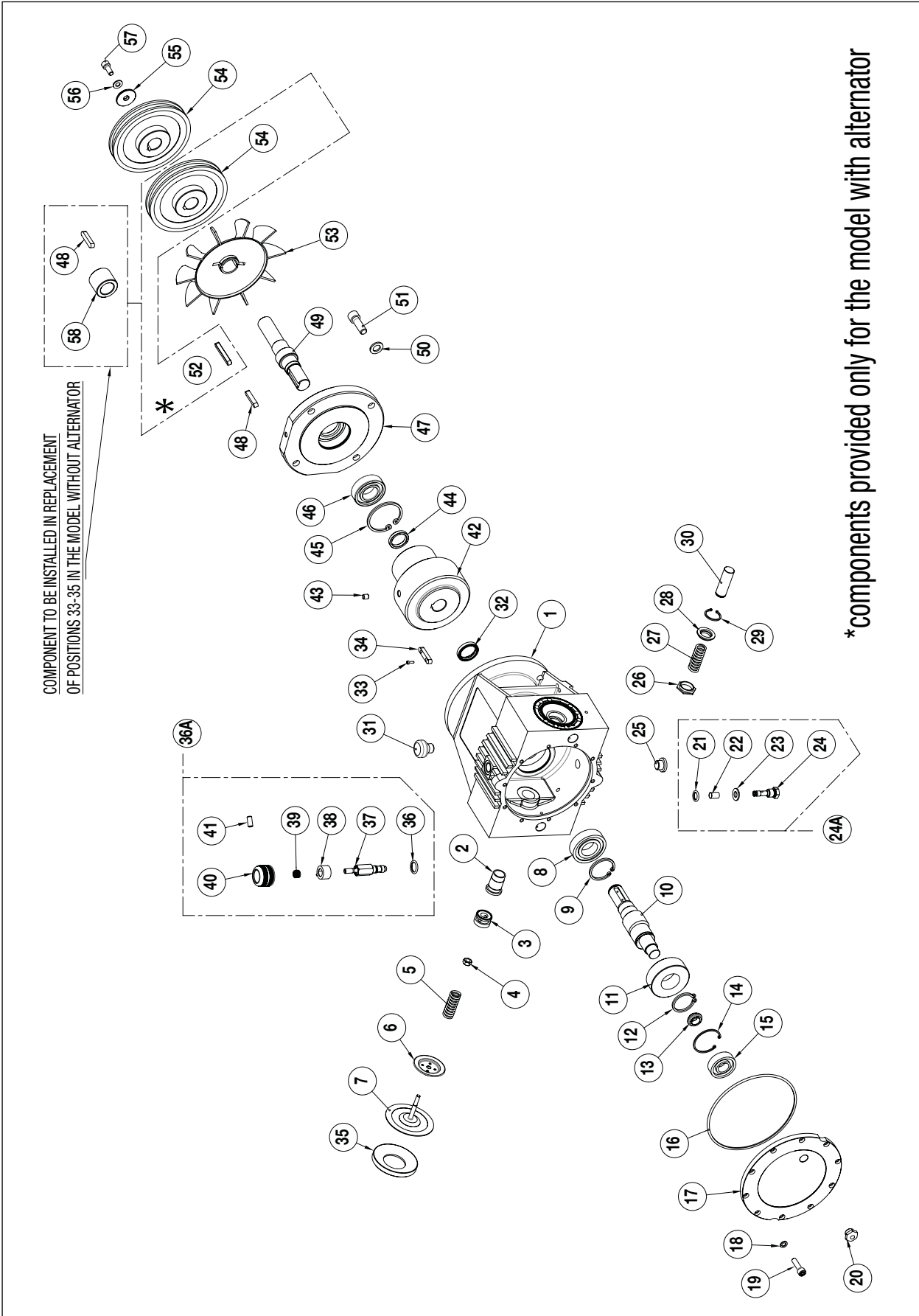

Pos.	Code	Description	Pos.	Code	Description
1	18711	Hydraulic body	31	82005	Plug oil
2	32018	Cylinder liner	32	31128	Corteco 28x38x7
3	32033	Piston insert	33	9308	Screw M3x8 UNI 5931
4*	3302/4	Nut	34	18716	Tab
5*	33002/3	Spring	35	33003	Diaphragm insert
6*	33002/2	Oil distributor	36A	32150	Valve assembly of pression
7*	33002/1	Diaphragm	36	32014	OR 9.8x1.5
8	31125	Bearing	37	32155	Valve body
9	81020	Elastic ring	38	32016	Retainer
10	18712	Eccentric Shaft	39	32017/2	Spring
11	18725	Eccentric Bearing	40	32017	Knob
12	12470	Elastic ring	41	32017/1	Dowel M5x12 2K
13	18175	Spacer	42	18387	flywheel-Sleeve
14	18727	Elastic ring	43	18142	Dowel M8x10 TC
15	18728	Bearing	44	18321	Spacer
16	18726	OR 4625	45	18341	Elastic ring
17	18713	Cover	46	42255	Bearing
18	12462	Washer	47	18314	Flange
19	81032	Screw M8x35	48	81014	Tab
20	32007	Plug inspection	49	18328	Shaft
21	32012	OR 2021	50	95114	Washer Ø 12
22	258	Filter	51	18171	Screw M12x25
23	32010	Washer 18x14,5x1,5	52	31166	Tab
24	12461	body Oil filter	53	18342	Fan
25	32108	Plug oil 3/8"	54	18320	Pulley
26	32041	Nut Cylinder liner	55	95153	Washer Ø 9x36
27	32022	Spring	56	34009	Washer Ø 8
28	32021	Washer	57	96031	Screw M8x25
29	32020	Elastic ring	58	18384	Spacer
30	32019	Piston			

T COMPLETE PUMP MOTOR BODY

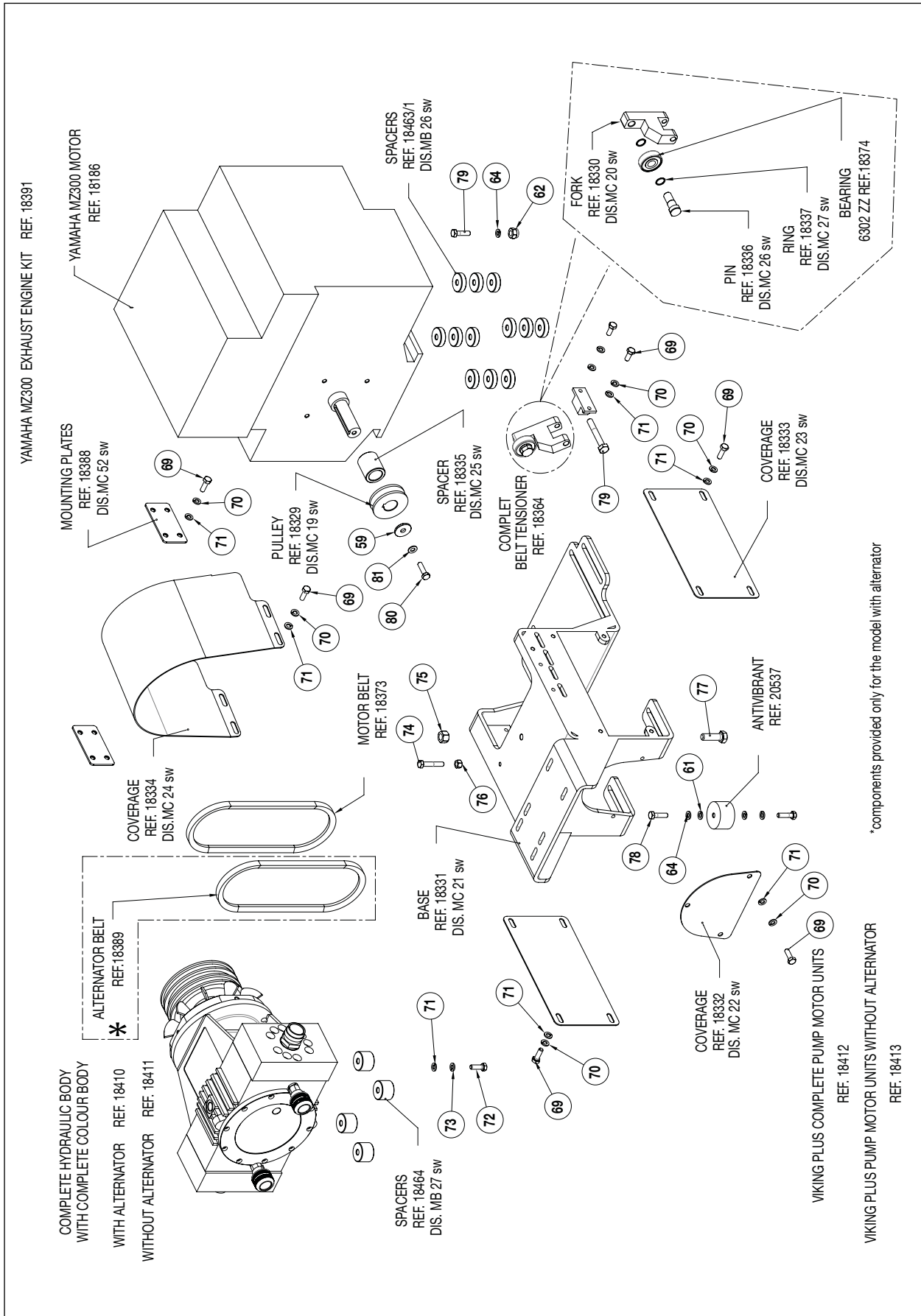

Pos.	Code	Description	Pos.	Code	Description
59	95153	Washer Ø 9x36	74	4436	Screw M8x70
61	95096	Washer Ø 10	75	96893	Nut M12
62	96080	Nut M10	76	52017	Nut M18
64	81033	Washer Ø 10	77	5755	Screw M12x120
69	32004	Screw M8x16	78	6130	Screw M10x20
70	34009	Washer schnor Ø 8	79	20560	Screw TE UNI5737 M10x60
71	32024	Washer Ø 8	80	18192	Screw TE 3/8-24
72	96031	Screw M8x25	81	33005	Washer schnor Ø 10
73	96030	Washer grower Ø 8			

U CARTER

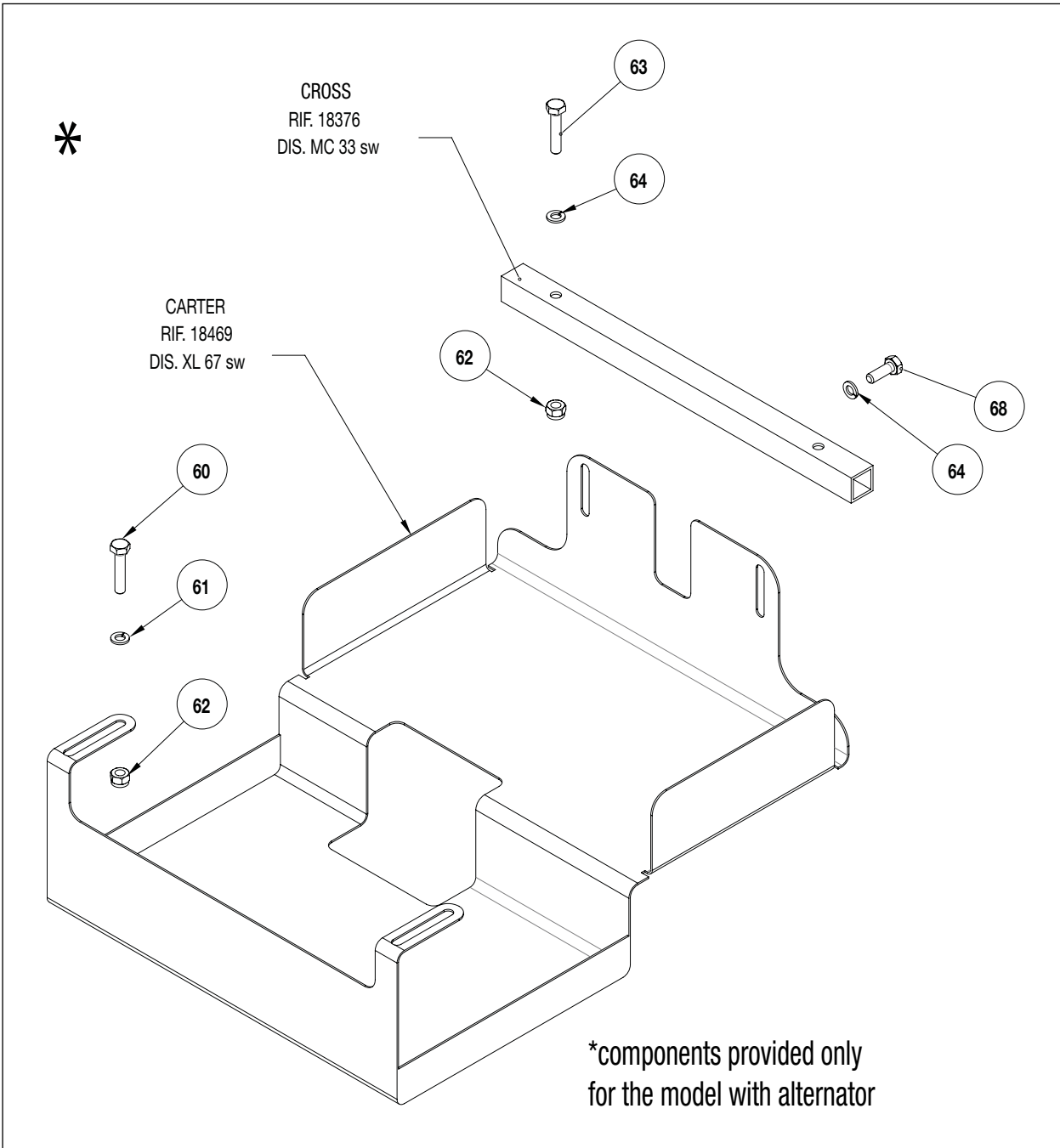

Pos.	Code	Description	Pos.	Code	Description
60	69107	Screw M10x80	63	20560	Screw M10x60
61	95096	Washer Ø 10	64	81033	Washer Ø 10
62	96080	Nut M10	68	6130	Screw M10x20

V ALTERNATOR

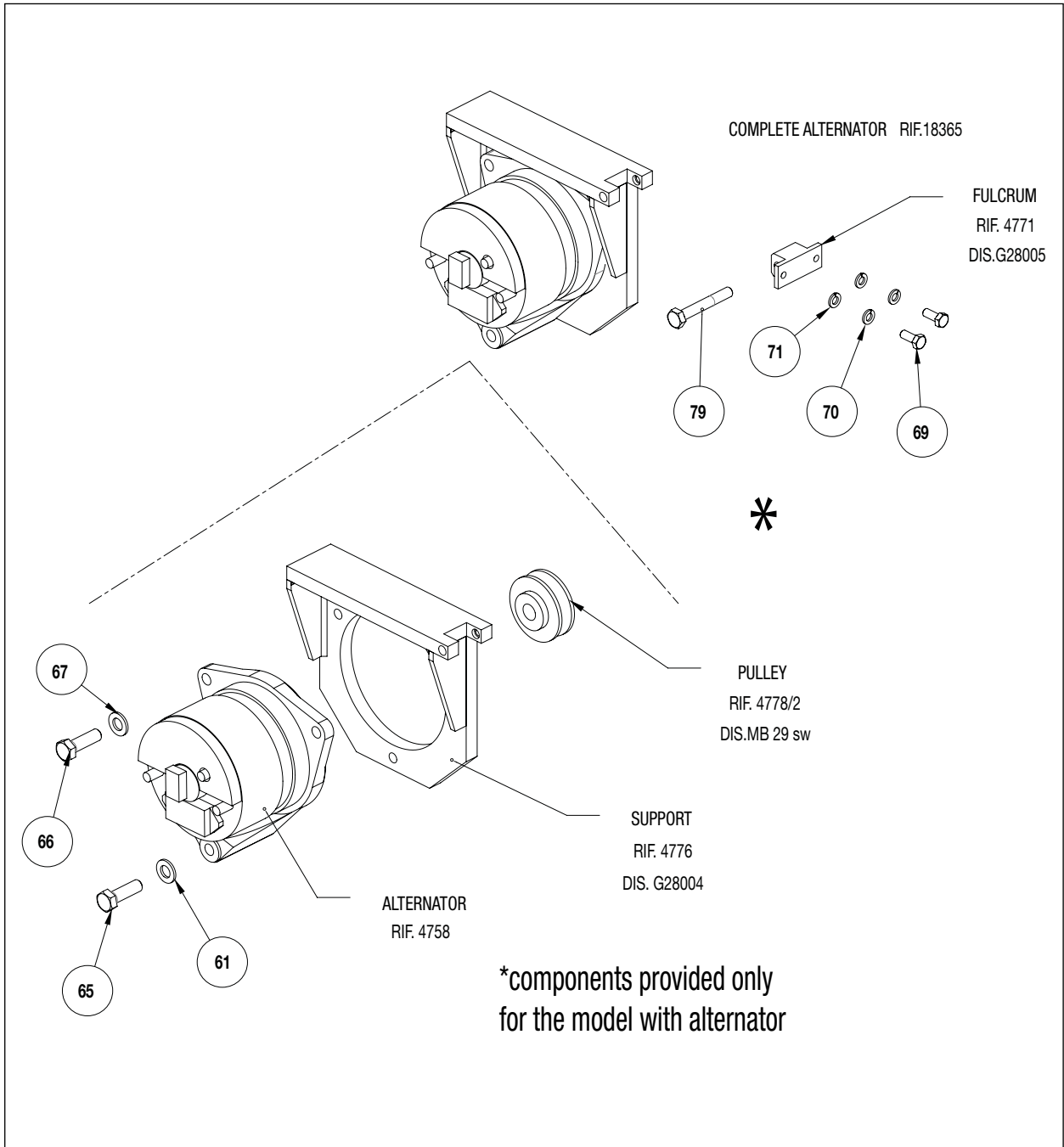

Pos.	Code	Description	Pos.	Code	Description
61	95096	Washer Ø 10	69	32004	Screw M8x16
65	4440	Screw M20x100	70	34009	Washer schnoro Ø 8
66	95083	Screw M12x40	71	32024	Washer Ø 8
67	95066	Washer Ø 12	79	20560	Screw TE UNI5737 M10x60

W FLOW REGULATORS

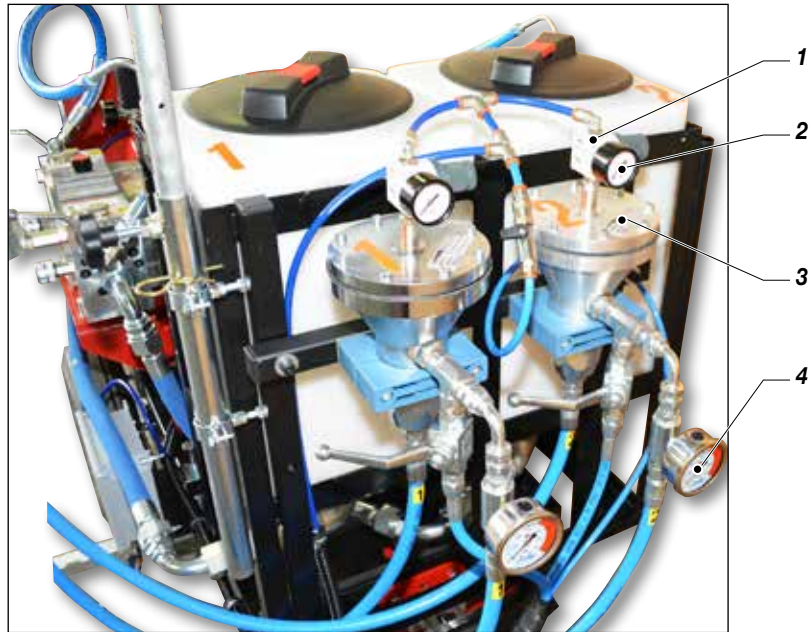

Pos.	Code	Description	Pos.	Code	Description
1	3344	Regulator	3	7130	Regulator
2	8167	Pressure gauge	4	147	Pressure gauge

X TANKS

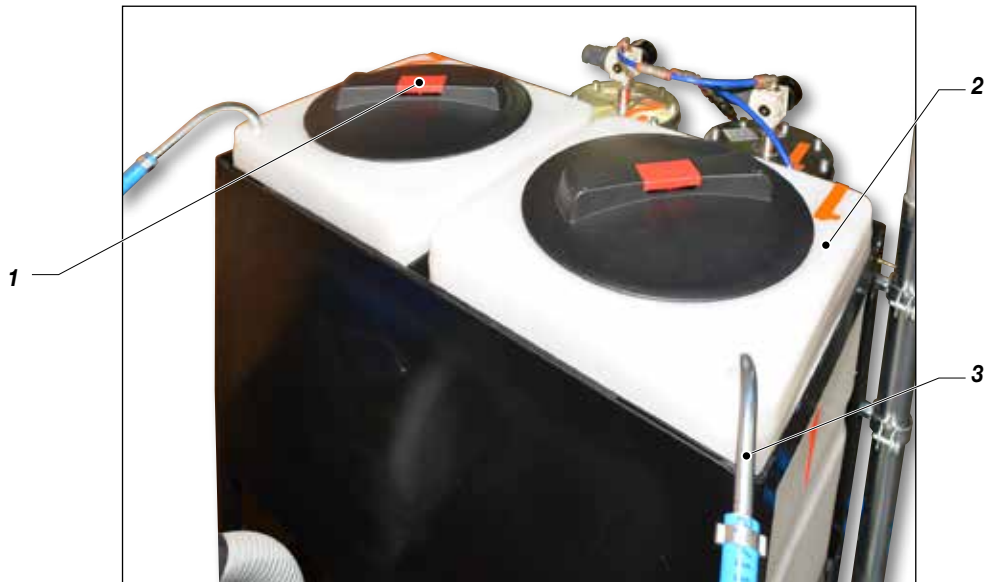

Pos.	Code	Description	Pos.	Code	Description
1	19510/1	Plug	2	20802/1	Light blue tank
2	20802	White tank	3	16609	Recirculation tube

Y CONTROL LEVER MECHANISMS

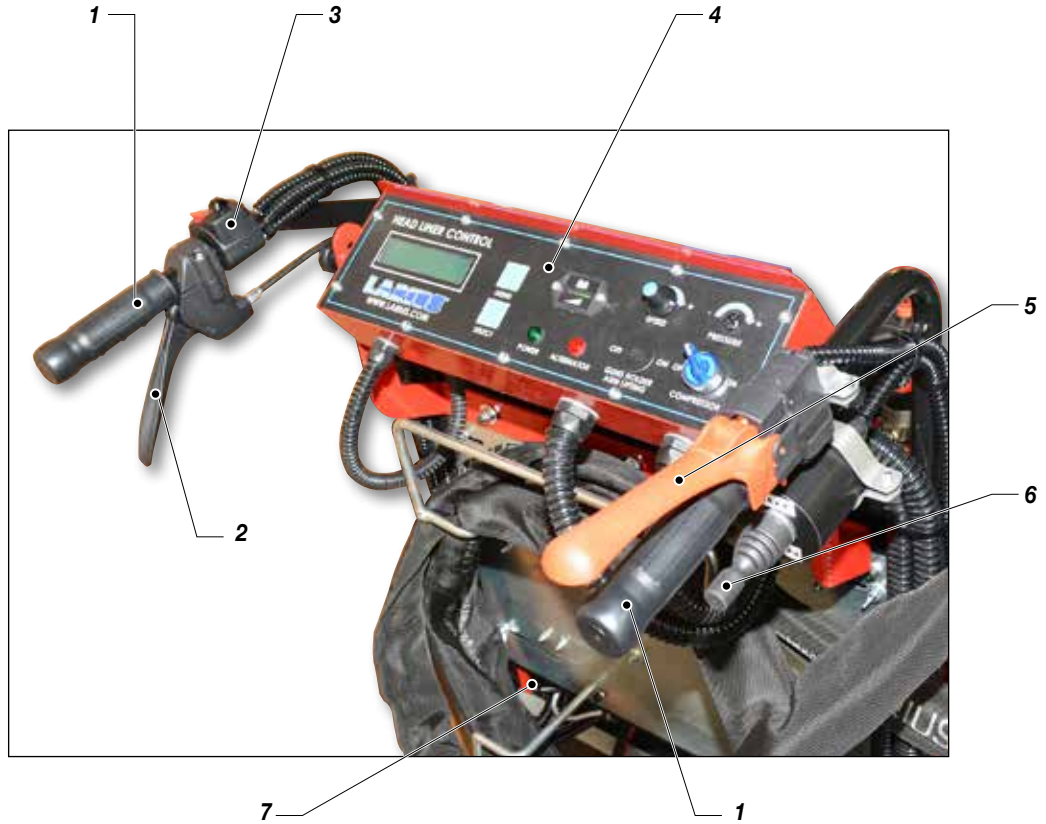

Pos.	Code	Description	Pos.	Code	Description
	4280	Electric geared motor complete with encoder	3	4012	Controls group
	4283	120Amp drive operation	4	4487	Control Head Liner panel units
1	4047	Knob	5	4046	Control lever
2	4464	Control lever	6	4769	Knob
			7	4010/1	Batteries

Z SPARE PARTS

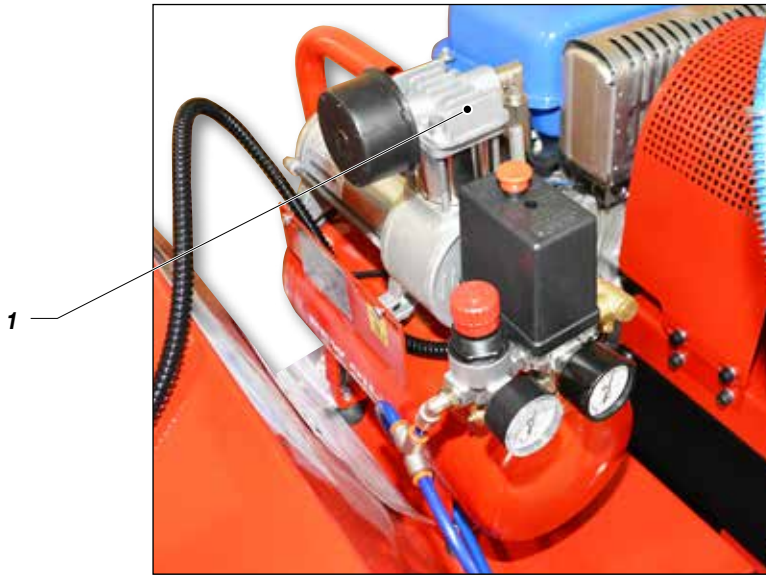

Pos.	Code	Description	Pos.	Code	Description
1	4770	Complete compressor			

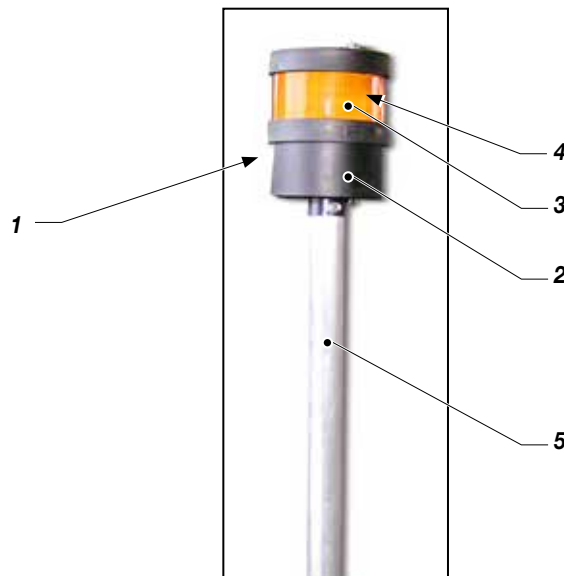

Pos.	Code	Description	Pos.	Code	Description
	4507	Kit flashing light with staff	4	4520/3	BA150 24V 5W micro lamp
1	4520	Flashing light Liner self-propelled	5	4520/4	Extendible extension mt. 5 3x0.75 NE
2	4520/1	Base+black cover flashing			
3	4520/2	Flashing luminous column			

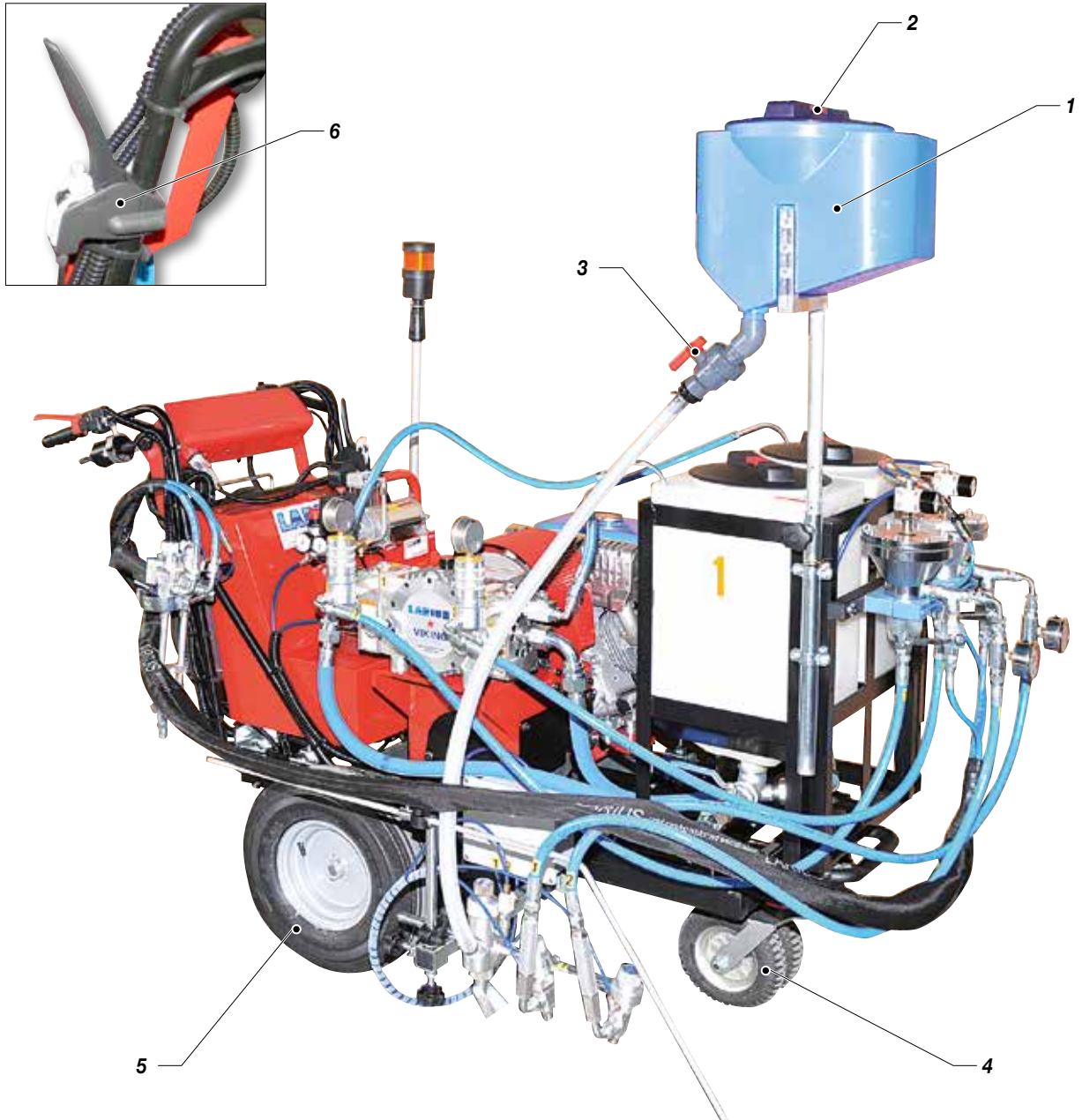

Pos.	Code	Description	Pos.	Code	Description
	4950/1	Viking Liner Plus bicomponent version	4	4732	Front wheel
1	19510	Tank	5	4493/1	Rear wheel
2	19510/1	Cap tank	6	4044	Lever kit
3	19517	1" PVC ball valve			

AA VIKING LINER CONTROL PANEL USE

Discharge pressure turning the knobs (X1).

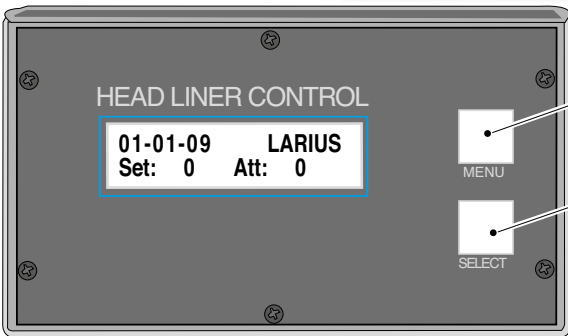

Display when the electronic box is switched on **Fig.1**

MENU key

SELECT key

- Activate by means of dedicated switch “0-1” on the right side of the control panel;
- The display shows date, time and temperature (see Fig. 1);
- Press the menu key to scroll through the list of functions from 1 through 9.



MENU 1: SETUP DATE

Press the “MENU” key and the first setting “1. DATE” will appear.

To change the date:

- Press the “SELECT” key to enter the page;
- Press “MENU” to change the numbers for the date;
- Press “SELECT” to shift from day to month and to year;
- Press “SELECT” from the year position to return to point “1. DATE”.

Press “MENU” to go on to point 2.



MENU 2: SETUP TIME

When “MENU” is pressed from point 1, the display shows “2. TIME”.

To change the time:

- Press the “SELECT” key to enter the page;
- Press “MENU” to change the numbers for the date;
- Press “SELECT” to shift from hour to minutes and seconds;
- Press “SELECT” from the second position to return to point “2. TIME”.

Press “MENU” to go on to point 3.



MENU 3: SETTING MAINTENANCE HOURS

When “MENU” is pressed from point 2, the display shows “3. MAINTENANCE HOURS”. This menu is used to set the n° of hours between successive maintenance tasks.

To change the time:

- Press the “SELECT” key to enter the page;
- Press “MENU” to increase the time set. Hold “MENU” down and press and release “SELECT” to invert the counter and therefore reduce the time set ;
- Press “SELECT” again to return to point “3. MAINTENANCE HOURS”.

Press “MENU” to go on to point 4.



MENU 4: MAINTENANCE ALERT

When “MENU” is pressed from point 3, the display shows “4. MAINTENANCE ALERT”. This menu is used to set the n° of hours prior warning for maintenance tasks.

To change:

- Press the “SELECT” key to enter the page;
- Press “MENU” to increase the time set. Hold “MENU” down and press and release “SELECT” to invert the counter and therefore reduce the time set;
- Press “SELECT” again to return to point “4. MAINTENANCE ALERT”.

Press “MENU” to go on to point 5.



MENU 5: MAINTENANCE DONE

When “MENU” is pressed from point 4, the display shows “5. MAINTENANCE DONE”. This menu is used to reset the countdown after having completed maintenance.

To change:

- Press the “SELECT” key to enter the page;
- Press “SELECT” again to confirm that maintenance has been done. The display automatically goes back to menu “5. MAINTENANCE DONE”.

Press “MENU” to go on to point 6.



MENU 6: TOTALS

When “MENU” is pressed from point 5, the display reads “6. TOTALS”. This menu shows the number of hours worked and the number of times the pump control clutch has been activated.

- Press the “MENU” or “SELECT” key to return to “6. TOTALS”.
- Press “MENU” to go on to point 7.



MENU 7: LANGUAGE

When "MENU" is pressed from point 6, the display shows "7. LANGUAGE". This menu can be used to set the language.

- Press the "SELECT" key to access the page, and the "MENU" key to switch from Italian to English and from English to Italian;
- Press "SELECT" to return to "7. LANGUAGE". Press "MENU" to go on to point 8.



MENU 8: SEQUENCER

When "MENU" is pressed from point 7, the display shows "8. SEQUENCER". This menu can be used to select or deselect the use of the automatic tracker.

- Press the "SELECT" key to access the page, and the "MENU" key to switch from sequencer YES or NO ;
- Press "SELECT" to return to "8. SEQUENCER". Press "MENU" to go on to point 9.



If "Sequencer YES" is selected, it is possible to enter the dotting setting menu described below.



MENU 9: RETURN

When "MENU" is pressed from point 8, the display reads "9. END". This menu is used to go back to the initial page.

- Press the "SELECT" key to return to the home page.

BB LINE SEQUENCING FUNCTION

From the home page, keep the "MENU" key pressed for more than 2 seconds to enter the line programming mode. (*Note. Only if Menu 8 was previously set to "Sequencer ON"*).

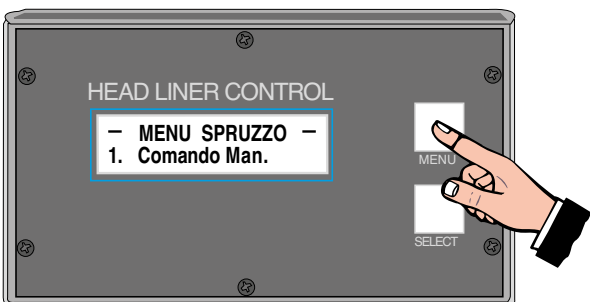

MENU 1: MANUAL COMMAND

This function allows one to decide which gun to use with the control lever in the "continuous" position. The possibilities are:

- Left gun only;
- Right gun only;
- Right and left guns and simultaneously;
- Press the menu button to change setting;
- Press the select key to exit.

Note: this menu refers only to the "MANUAL" ("MAN") line.



MENU 2: RIGHT LINE

This function allows the programming of the length of the dashed line.

- Press menu key until page 2 is displayed;
- Press select key to enter the page;
- Press the menu key to increase the set value;
- Hold “MENU” down and press and release “SELECT” to invert the counter (*and therefore reduce the value set*).
- Press select to exit.



MENU 3: RIGHT SPACE

This function allows the programming of the length of the blank area between dashes.

- Press menu key until page 3 is displayed;
- Press select key to enter the page;
- Press the menu key to increase the set value;
- Hold “MENU” down and press and release “SELECT” to invert the counter (*and therefore reduce the value set*).
- Press select to exit.



MENU 4: LEFT LINE

This function allows for the programming of the length of the dashed line.

- Press menu key until page 4 is displayed;
- Press select key to enter the page;
- Press the menu key to increase the set value;
- Hold “MENU” down and press and release “SELECT” to invert the counter (*and therefore reduce the value set*).
- Press select to exit.



MENU 5: LEFT SPACE

This function allows for the programming of the length of the blank area between dashes.

- Press menu key until page 5 is displayed;
- Press select key to enter the page;
- Press the menu key to increase the set value;
- Hold “MENU” down and press and release “SELECT” to invert the counter (*and therefore reduce the value set*).
- Press select to exit.



MENU 6: START LEFT SPACE

This function allows for the spray delay to be set exclusively for the left gun.



MENU 7: AUTOMATIC SPRAY COMMAND

This function allows to set the guns to be used with the lever in the “AUTOMATIC” (“AUT”) position.

- Press menu key until page 7 is displayed;
- Press the select key to enter the page.

Possible settings are:

- Left gun off + Right gun dashed;
- Left gun off + Right gun continuous;
- Left gun dashed + Right gun dashed;
- Left gun dashed + Right gun continuous;
- Left gun continuous + Right gun dashed
- Press the menu key to choose the desired setting;
- Press select to exit.



MENU 8: DISTANCE

This function allows to set the distance of work before the sprayer stops.

- Press menu key until page 8 is displayed;
- Press select key to enter the page;
- Press the menu key to increase the set value;
- Holding down the menu key, press and release the select key to decrease the set value;
- Press select to exit.

N.B.: the value “0” disenables the control.



MENU 9: STEP LENGTH

This function is used to correct any errors that may occur between the dotted line entered and the line actually made.

- Press the “MENU” key until page 9 is displayed;
- Press the “SELECT” key to enter the page;
- Press the “MENU” key to increase the value set (*the line length is reduced*);
- Hold “MENU” down and press and release “SELECT” to invert the counter (and therefore reduce the value set). The length of the line increases;
- Press “SELECT” to exit.

N.B.: the step length is already set in the factory and generally does not need to be changed.



MENU 10: RETURN

This function is used to go back to the home page.

- Press the “MENU” key until page 10 is displayed;
- Press the “SELECT” key to return to the home page.

Once the various options have been set, it is possible to shift from the manual to the automatic spraying by simply changing the position of the control lever:

AUT = AUTOMATIC (works using the settings in menu “2. LINE”, “3. SPACE” and “7.COMMAND”).

MAN = MANUAL (works using the settings in menu “1. MANUAL COMMAND”).

CC ACCESSORIES

WARNING: Always indicate code and quantity for each part required



Art. 11220: AT 250 1/4+base
Art. 11221: AT 250 M16x1,5+base



Code 11080: AT 300 1/4+base
Code 11081: AT 300 M16x1,5+base



Code 11135: L91X 1/4+base
Code 11136: L91X M16x1,5+base



Art. 95218: 30 MESH FILTER
Art. 95219: 60 MESH FILTER
Art. 95220: 100 MESH FILTER
Art. 95221: 200 MESH FILTER



Art. 4038: LASER POINTER



Art. 4506: ADJUSTABLE SPOTLIGHT



Art. 4507: FLASHING LIGHT

Art. 26000: OPERATOR FOOTBOARD



Art. 4720: SEAT KIT

SUPER FAST-CLEAN



SUPER FAST-CLEAN TIP

Nozzles code		
SFC07-20	SFC19-60	SFC29-80
SFC07-40	SFC21-20	SFC31-40
SFC09-20	SFC21-40	SFC31-60
SFC09-40	SFC21-60	SFC31-80
SFC11-20	SFC23-20	SFC33-40
SFC11-40	SFC23-40	SFC33-60
SFC13-20	SFC23-60	SFC33-80
SFC13-40	SFC25-20	SFC39-40
SFC13-60	SFC25-40	SFC39-60
SFC15-20	SFC25-60	SFC39-80
SFC15-40	SFC27-20	SFC43-40
SFC15-60	SFC27-40	SFC43-60
SFC17-20	SFC27-60	SFC43-80
SFC17-40	SFC27-80	SFC51-40
SFC17-60	SFC29-20	SFC51-60
SFC19-20	SFC29-40	SFC51-80
SFC19-40	SFC29-60	

Art. 18280: GASKETS



Art. 18270: SUPER FAST-CLEAN base UE 11/16x16

Nozzles code

TSC 07-20	TSC 19-20
TSC 07-40	TSC 19-40
TSC 09-20	TSC 19-60
TSC 09-40	TSC 21-20
TSC 11-20	TSC 21-40
TSC 11-40	TSC 21-60
TSC 13-20	TSC 23-20
TSC 13-40	TSC 23-40
TSC 13-60	TSC 23-60
TSC 15-20	TSC 27-20
TSC 15-40	TSC 27-40
TSC 15-60	TSC 27-60
TSC 17-20	TSC 31-40
TSC 17-40	TSC 31-60
TSC 17-60	

TOP SPRAYING CLEAN



From size 7-20 to 31-60

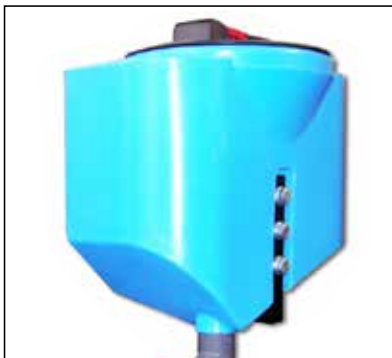

**Code 4405:
REFLECTING PEARLS TANK WITH DISPENSER**

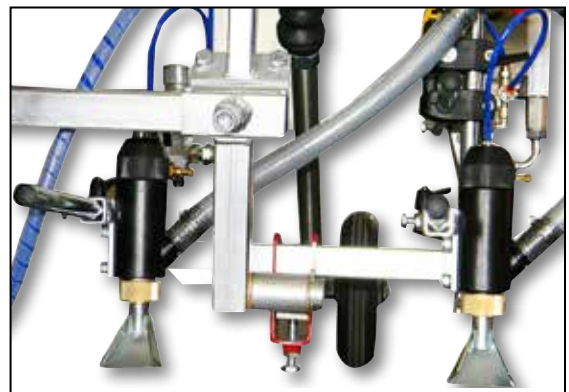

**Code 4500:
MICROSPHERES DISPENSER**

**GUN EXTENSION**

Art. 153: cm 30

Art. 155: cm 60 - Art. 156: cm 100

**COMPLETE FAST-CLEAN EXTENSION**

Art. 170: cm 30

Art. 171: cm 60 - Art. 172: cm 100

**PLA 1/4"****+ FAST-CLEAN
WITH NOZZLE**

Art. 11420-11425-11430: cm 130-180-240

PLA M16x1,5**+ FAST-CLEAN WITH NOZZLE**

Art. 11421-11426-11431: cm 130-180-240

**Art. 16780: TELESCOPIC PAINT ROLLER**

Gun 220 bar

Extension 1300 - 2000 mm

**PLA**

Art. 11400: cm 130

Art. 11401: cm 180 - Art. 11402: cm 240

**TUBES MANUAL WINDER**

3/16" - 3/8" - 1/4" max width mt. 20



CE DECLARATION OF CONFORMITY



Company



LARIUS srl
Via Antonio Stoppani 21 - 23801 Calolziocorte (LC) ITALY
Tel: +39 0341 621152
Fax: +39 0341 621243
E-mail: larius@larius.com

Declares under his owns responsibility that the product:

VIKING LINER PLUS **Airless professional road marking bicomponent version 2k 1:1**

complies with the directives: | - EC Directive 2006/42 Machinery Directive

furthermore to the
harmonized standards: | - UNI EN ISO 12100-1/-2
Machinery safety, basic concepts, general principles of design. Basic terminology, methodology. Technical principles.

This declaration relates exclusively to the product in the state in which it was placed on the market, and excludes components or modifications which are added or carried out subsequently by end user.

Calolziocorte, 03 January 2024
Location / Date

Signature

Pierangelo Castagna
Managing Director



**SAMOA INDUSTRIAL, S.A. - HEADQUARTERS
SPAIN AND EXPORT MARKETS**

POL. IND. PORCEYO, I-14 - CAMINO DEL FONTÁN, 831
E-33392 GIJÓN (ASTURIAS), SPAIN
TEL.: +34 985 381 488 - FAX: + 34 985 147 213

**SAMOA S.A.R.L.
FRANCE**

P.A.E.I. DU GIESSEN
3, RUE DE BRISCHBACH
67750 SCHERWILLER, FRANCE
TEL.: +33 3 88 82 79 62 - FAX: +33 3 88 82 77 88

**SAMOA ITALIA - LARIUS
ITALY**

VIA ANTONIO STOPPANI,21
23801 CALOLZIOCORTE (LC) ITALY
Tel.: +39 0341 621152 - Fax: + 39 0341 621242

SAMOA FLOWTECH GMBH

GERMANY, AUSTRIA, SWITZERLAND, THE NETHERLANDS AND GREECE
AM OBEREICHHOLZ 4
D - 97828 MARKTHEIDENFELD, GERMANY
TEL.: +49 9391 9826 0 - FAX: +49 9391 98 26 50

SAMOA LTD.

UNITED KINGDOM AND REP. OF IRELAND

ASTURIAS HOUSE - BARRS FOLD ROAD
WINGATES INDUSTRIAL PARK
WESTHOUGHTON, BL5 3XP, UK
TEL.: +44 1942 850600 - FAX: +44 1942 812160



SAMOA CORPORATION

USA AND CANADA
90 MONTICELLO ROAD
WEAVERVILLE, NC 28787, USA
TEL. +1 (828) 645-2290 - FAX: +1 (828) 658 0840



©Copyright, SAMOA INDUSTRIAL, S.A.
SAMOA Industrial, S.A. is an ISO 9001, ISO 14001 and ISO 45001 certified company.

»»» Contact us today!
Visit www.samoaindustrial.com for more information.

INSTRUCTION MANUAL AVAILABLE IN:		
	IT	https://www.larius.com/wp-content/uploads/VIKING_LINER_PLUS_2K_I.pdf
	EN	https://www.larius.com/wp-content/uploads/VIKING_LINER_PLUS_2K_UK.pdf