



www.larius.com



NOVA 20:1 PNEUMATIC WASHING PUMP

HIGH-PRESSURE,
HIGH-VOLUME WASH PUMPS
FOR INTENSIVE CLEANING
IN HAZARDOUS ENVIRONMENTS

USABLE WITH COLD OR HOT WATER UP TO 90°

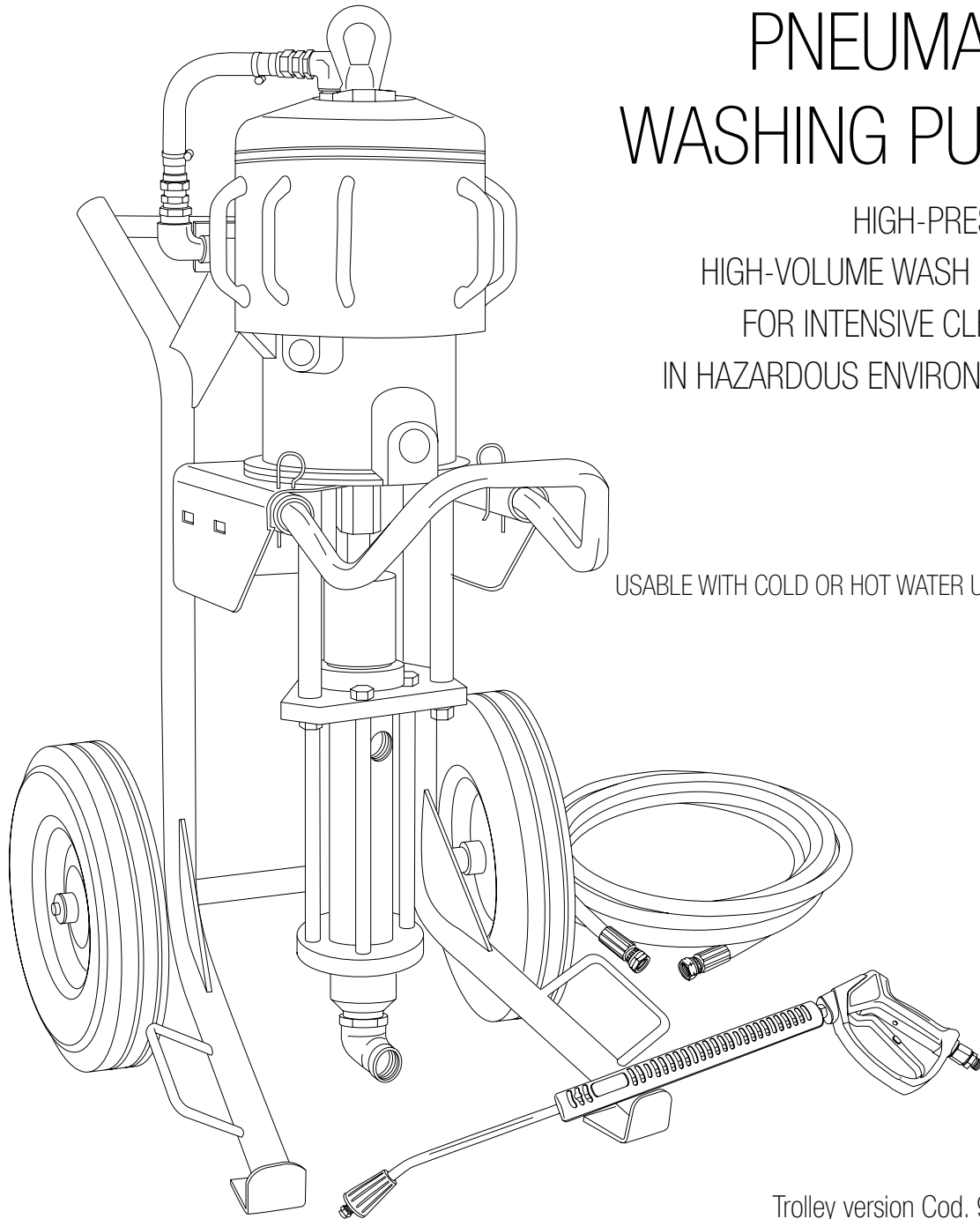

Trolley version Cod. 95799/1

Wall version Cod. 95760



- IT https://www.larius.com/wp-content/uploads/NOVA_20_1_WASH_PUMP_I.pdf
- EN https://www.larius.com/wp-content/uploads/NOVA_20_1_WASH_PUMP_UK.pdf
- ES https://www.larius.com/wp-content/uploads/NOVA_20_1_WASH_PUMP_ES.pdf



This manual is to be considered as an English language translation of the original manual in Italian. The manufacturer shall bear no responsibility for any damages or inconveniences that may arise due to the incorrect translation of the instructions contained within the original manual in Italian.

Due to a constant product improvement programme, the factory reserves the right to modify technical details mentioned in this manual without prior notice.



NOVA 20:1

Pneumatic washing pumps

INDEX

| | | |
|----------|--|----|
| A | WARNINGS | 4 |
| B | WORKING PRINCIPLE | 5 |
| C | TECHNICAL DATA | 6 |
| D | DESCRIPTION OF THE EQUIPMENT | 6 |
| E | TRANSPORT AND UNPACKING | 7 |
| F | CONDITIONS OF GUARANTEE | 7 |
| G | SAFETY RULES..... | 7 |
| H | ANTIFREEZE SYSTEM | 8 |
| I | GROUNDING..... | 9 |
| J | SETTING UP | 9 |
| K | WALL MOUNTING..... | 9 |
| L | WORKING | 10 |
| M | CLEANING AT THE END OF THE WORK..... | 10 |
| N | ROUTINE MAINTENAINCE | 10 |
| O | TROUBLESHOOTING | 11 |
| P | DISASSEMBLY OF THE PNEUMATIC MOTOR..... | 12 |
| Q | MOTOR GROUP SPARE PARTS | 18 |
| R | PUMPING GROUP SPARE PARTS..... | 22 |
| S | COMPLETE TROLLEY..... | 23 |
| T | AIR GROUP SPARE PARTS - TROLLEY VERSION COD. 95145 | 24 |
| U | AIR GROUP SPARE PARTS - WALL VERSION COD. 95145/1 | 24 |
| V | ACCESSORIES..... | 25 |
| W | ATEX CERTIFICATION | 25 |
| | DECLARATION OF CONFORMITY | 29 |

**WE ADVISE THE USE OF THIS EQUIPMENT ONLY BY PROFESSIONAL OPERATORS.
 ONLY USE THIS MACHINE FOR USAGE SPECIFICALLY MENTIONED IN THIS MANUAL.**

Thank you for choosing a **SAMOA** product.
 As well as the product purchased, you will receive a range of support services
 enabling you to achieve the results desired, quickly and professionally.



A WARNINGS

The table below provides the meaning of the symbols used in this manual in relation to using, earthing, operating, maintaining, and repairing of this equipment.

| | |
|--|---|
| | <ul style="list-style-type: none"> • Read this operator's manual carefully before using the equipment. • An improper use of this machine can cause injuries to people or things. • Do not use this machine when under the influence of drugs or alcohol. • Do not modify the equipment under any circumstances. • Use products and solvents that are compatible with the various parts of the equipment, and read the manufacturer's warnings carefully. • See the Technical Details for the equipment given in the Manual. • Check the equipment for worn parts once a day. If any worn parts are found, replace them using ONLY original spare parts. • Keep children and animals away from work area. • Comply with all safety standards. |
| | <ul style="list-style-type: none"> • It indicates an accident risk or serious damage to equipment if this warning is not followed. |
| | <p>FIRE AND EXPLOSION HAZARD</p> <ul style="list-style-type: none"> • Solvent and paint fumes in work area can ignite or explode. • To help prevent fire and explosion: <ul style="list-style-type: none"> - Use equipment ONLY in well ventilated area. - Eliminate all ignition sources, such as pilot lights, cigarettes and plastic drop cloths (potential static arc). - Ground equipment and conductive objects. - Use only grounded hoses. - Do not use trichloroethane, methylene chloride, other halogenated hydrocarbon solvents or fluids containing such solvents in pressurized aluminium equipment. Such use can cause serious chemical reaction and equipment rupture, and result in death, serious injury, and property damage. - Do not form connections or switch light switches on or off if the air contains inflammable fumes. • If electrical shocks or discharges are encountered the operation being carried out using the equipment must be stopped immediately. • Keep a fire extinguisher at hand in the immediate vicinity of the work area. |
| | <ul style="list-style-type: none"> • It indicates wound and finger squashing risk due to movable parts in the equipment. • Keep away from moving parts. • Do not use the equipment without the proper protection. • Before any inspection or maintenance of the equipment, carry out the decompression procedure explained in this manual, and prevent any risk of the equipment starting unexpectedly. |
| | <ul style="list-style-type: none"> • Report any risk of chemical reaction or explosion if this warning has not been given. • (IF PROVIDED) There is a risk of injury or serious lesion related to contact with the jet from the spray gun. If this should occur, IMMEDIATELY contact a doctor, indicating the type of product injected. • (IF PROVIDED) Do not spray before the guard has been placed over the nozzle and the trigger on the spray gun. • (IF PROVIDED) Do not put your fingers in the spray gun nozzle. • Once work has been completed, before carrying out any maintenance, complete the decompression procedure. |
| | <ul style="list-style-type: none"> • It indicates important recommendations about disposal and recycling process of products in accordance with the environmental regulations. |
| | <ul style="list-style-type: none"> • Mark any clamps attached to earth cables. • Use ONLY 3-wire extension cords and grounded electrical outlets. • Before starting work make sure that the electrical system is grounded and that it complies with safety standards. • High-pressure fluid from gun, hose leaks, or ruptured components will pierce skin. • To help prevent injection, always: <ul style="list-style-type: none"> - (IF PROVIDED) Engage trigger lock when not spraying. - (IF PROVIDED) Do not put your hand over the spray tip. Do not stop or deflect leaks with your hand, body or other. - (IF PROVIDED) Do not point gun at anyone or at any part of the body. - (IF PROVIDED) Never spray without tip guard. - Do pressure relief if you stop spraying or being servicing sprayer and before any maintenance operations. - Do not use components rated less than sprayer Maximum Working Pressure. - Never allow children to use this unit - (IF PROVIDED) Brace yourself; gun may recoil when triggered. |
| | <p>If high pressure fluid pierces your skin, the injury might look like "just a cut", but it is a serious wound! Get immediate medical attention.</p> |
| | <ul style="list-style-type: none"> • It is obligatory to wear suitable clothing as gloves, goggles and face shield. • Wear clothing that complies with the safety standards in force in the country in which the equipment is used. • Do not wear bracelets, earrings, rings, chains, or anything else that may hinder the operator's work. • Do not wear clothing with wide sleeves, scarves, ties, or any other piece of clothing that could get tangled up in moving parts of the equipment during the work, inspection, or maintenance cycles. |

B WORKING PRINCIPLE

NOVA 20:1 PNEUMATIC WASHING PUMP is a high pressure pneumatic pump for professional use to be used for cleaning with water.

reciprocating movement of the motor piston; this movement is transmitted through a connecting rod to the material pumping piston which allows to suck water.

NOVA pump is essentially constituted of an air motor and a structure called «pumping group» .
In the pneumatic motor, compressed air causes the vertical

The ratio 20:1 means that the outlet pressure of water is 20 times higher than the pump feed air pressure.

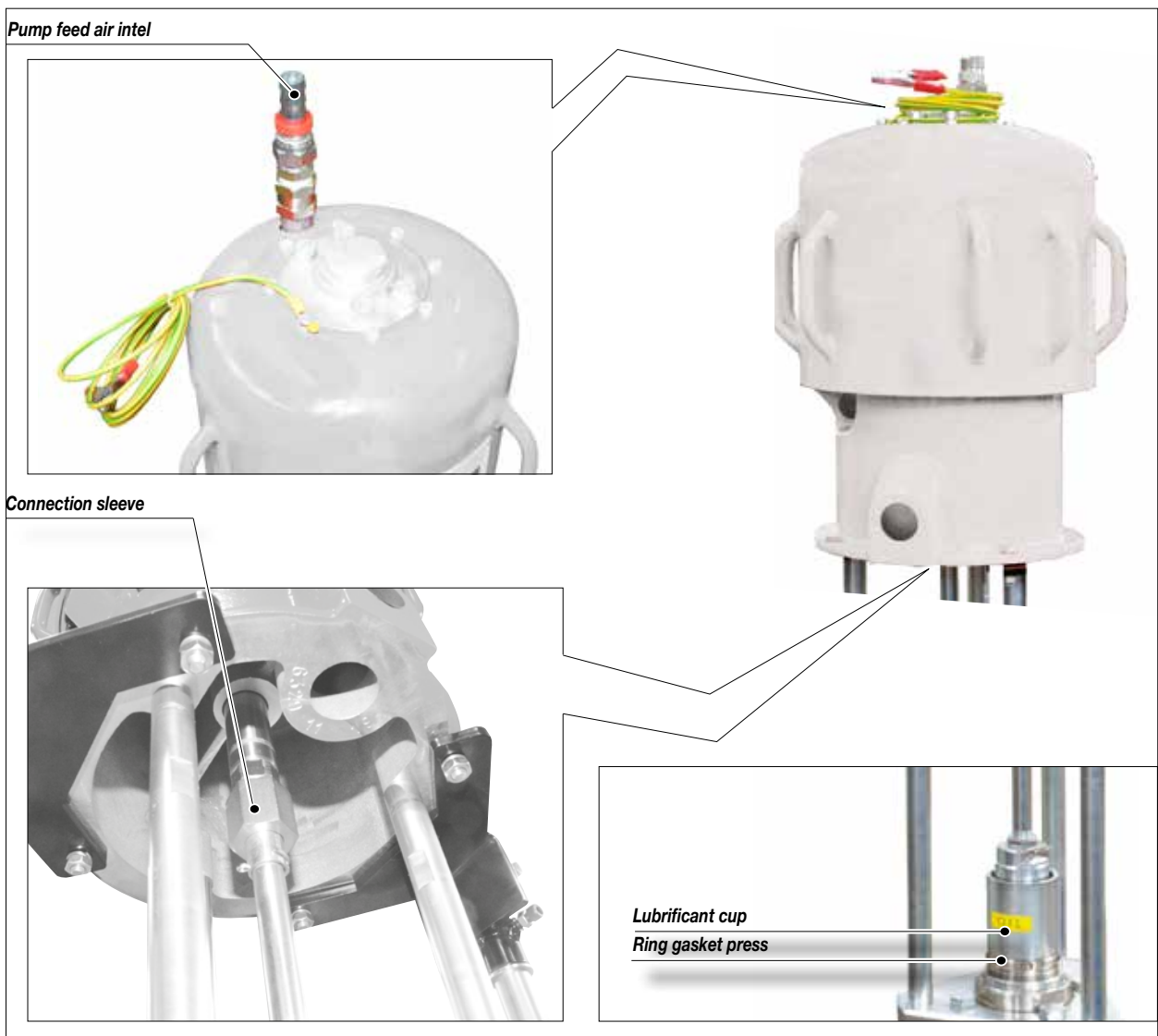

Fig. 1



C TECHNICAL DATA

NOVA 20:1 PNEUMATIC WASHING PUMP

| | |
|-----------------------|--------------|
| Feeding air pressure | 7 bar |
| Max water pressure | 140 bar |
| Feeding air inlet | 3/4" GAS (M) |
| Max delivery | 32 l/min |
| Material output | 1½" GAS (F) |
| Max water temperature | 90° |

Parts of the pump in contact with water

Pumping group: steel stainless steel AISI 303 and 420B

Sealing balls: stainless steel AISI 420B

Gaskets: PTFE



The disposal of some parts of the pump no more usable is a customer's competence and must be performed in accordance with the regulations in force in the country where the plant is installed and used.

D DESCRIPTION OF THE EQUIPMENT

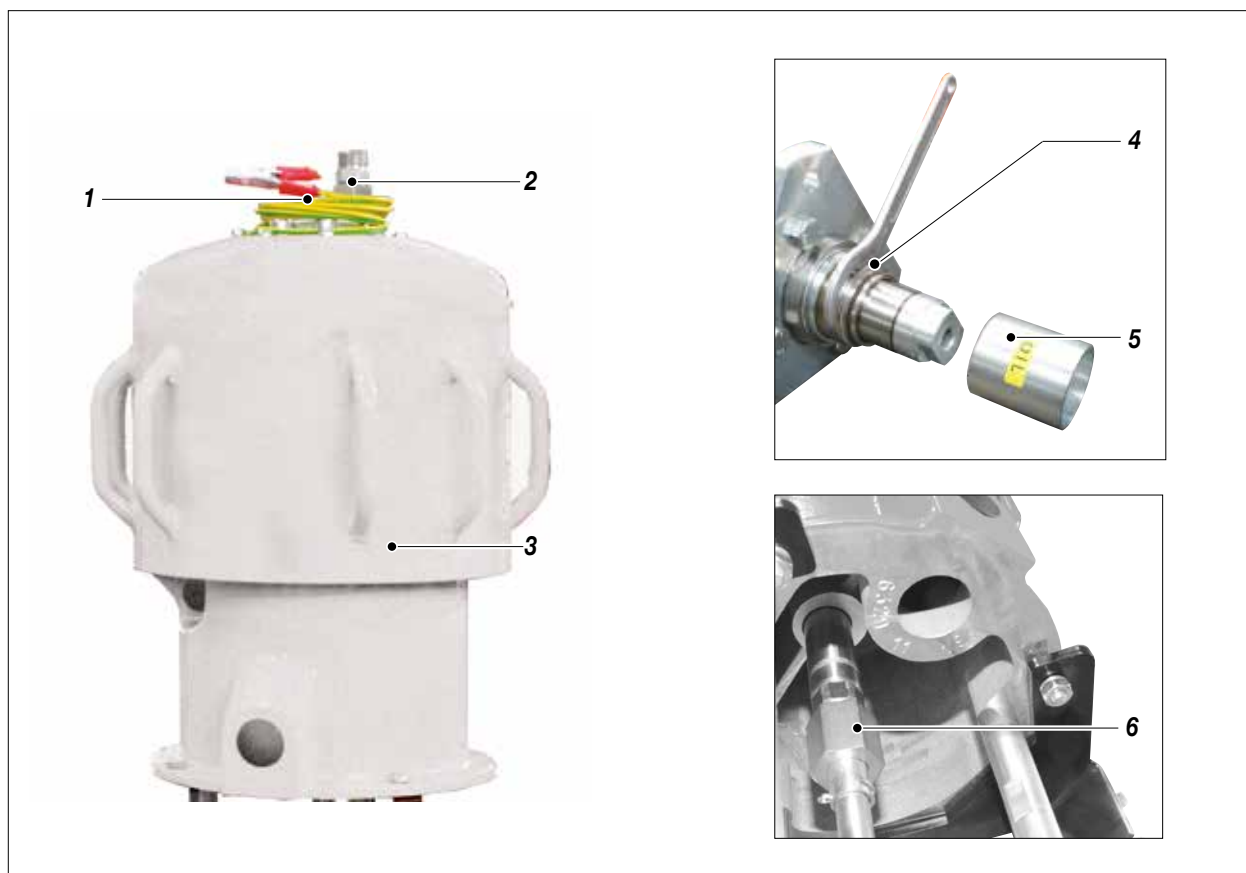

Fig. 1

| Pos. | Description |
|------|---------------------|
| 1 | Grounding cable |
| 2 | Pump feed air inlet |
| 3 | Pneumatic motor |

| Pos. | Description |
|------|-------------------|
| 4 | Ring gasket press |
| 5 | Lubricant cap |
| 6 | Connection sleeve |



E TRANSPORT AND UNPACKING

- The packed parts should be handled as indicated in the symbols and markings on the outside of the packing.
- Before installing the equipment, ensure that the area to be used is large enough for such purposes, is properly lit and has a clean, smooth floor surface.
- The user is responsible for the operations of unloading and handling and should use the maximum care so as not to damage the individual parts or injure anyone.

To perform the unloading operation, use only qualified and trained personnel (truck and crane operators, etc.) and also suitable hoisting equipment for the weight of the installation or its parts.

Follow carefully all the safety rules.

The personnel must be equipped with the necessary safety clothing.

- The manufacturer will not be responsible for the unloading operations and transport to the workplace of the machine.
- Check the packing is undamaged on receipt of the equipment. Unpack the machine and verify if there has been any damage due to transportation.

In case of damage, call immediately the manufacturer and the Shipping Agent. All the notices about possible damage or anomalies must arrive timely within 8 days at least from the date of receipt of the plant through Registered Letter to the Shipping Agent and to the manufacturer.



The disposal of packaging materials is a customer's competence and must be performed in accordance with the regulations in force in the country where the plant is installed and used. It is nevertheless sound practice to recycle packaging materials in an environment-friendly manner as much as possible.

F CONDITIONS OF GUARANTEE



The conditions of guarantee do not apply in the following situations:

- improper washing and cleaning of components causing malfunction, wear or damage to the equipment or any of its parts;
- improper use of the equipment;
- use that does not conform with applicable national legislation;
- incorrect or faulty installation;
- modifications, interventions and maintenance that have not been authorised by the manufacturer;
- use of non-original spare parts or parts that do not correspond to the specific model;
- total or partial non-compliance with the instructions provided.

G SAFETY RULES



Read carefully and entirely the following instructions before using the product. Please save these instructions in a safe place.



The unauthorised tampering/replacement of one or more parts composing the machine, the use of accessories, tools, expendable materials other than those recommended by the manufacturer can be a danger of accident.



The manufacturer will be relieved from tort and criminal liability.

- THE EMPLOYER SHALL TRAIN ITS EMPLOYEES ABOUT ALL THOSE RISKS STEMMING FROM ACCIDENTS, ABOUT THE USE OF SAFETY DEVICES FOR THEIR OWN SAFETY AND ABOUT THE GENERAL RULES FOR ACCIDENT PREVENTION IN COMPLIANCE WITH INTERNATIONAL REGULATIONS AND WITH THE LAWS OF THE COUNTRY WHERE THE PLANT IS USED.
- THE BEHAVIOUR OF THE EMPLOYEES SHALL STRICTLY COMPLY WITH THE ACCIDENT PREVENTION AND ALSO ENVIRONMENTAL REGULATIONS IN FORCE IN THE COUNTRY WHERE THE PLANT IS INSTALLED AND USED.
- KEEP YOUR WORK PLACE CLEAN AND TIDY. DISORDER WHERE YOU ARE WORKING CREATES A POTENTIAL RISK OF ACCIDENTS.
- ALWAYS KEEP PROPER BALANCE AVOIDING UNUSUAL STANCE.
- BEFORE USING THE TOOL, ENSURE THERE ARE NOT DAMAGED PARTS AND THE MACHINE CAN WORK PROPERLY.
- ALWAYS FOLLOW THE INSTRUCTIONS ABOUT SAFETY AND THE REGULATIONS IN FORCE.
- KEEP THOSE WHO ARE NOT RESPONSIBLE FOR THE EQUIPMENT OUT OF THE WORK AREA.
- **NEVER** EXCEED THE MAXIMUM WORKING PRESSURE INDICATED.
- (IF PROVIDED) **NEVER** POINT THE SPRAY GUN AT YOURSELVES OR AT OTHER PEOPLE. THE CONTACT WITH THE CASTING CAN CAUSE SERIOUS INJURIES. **NEVER** UNDERVALUE A WOUND CAUSED BY THE INJECTION OF A FLUID.
- RELEASE THE PRESSURE IN THE CIRCUIT BEFORE PERFORMING ANY CHECK OR PART REPLACEMENT OF THE EQUIPMENT.
- NEVER MODIFY ANY PART IN THE EQUIPMENT. CHECK REGULARLY THE COMPONENTS OF THE SYSTEM. REPLACE THE PARTS DAMAGED OR WORN.
- (IF PROVIDED) TIGHTEN AND CHECK ALL THE FITTINGS



FOR CONNECTION BETWEEN PUMP, FLEXIBLE HOSE AND SPRAY GUN BEFORE USING THE EQUIPMENT.

- ALWAYS USE THE FLEXIBLE HOSE SUPPLIED WITH STANDARD KIT.
- THE USE OF ANY ACCESSORIES OR TOOLING OTHER THAN THOSE RECOMMENDED IN THIS MANUAL, MAY CAUSE DAMAGE OR INJURE THE OPERATOR.
- THE FLUID CONTAINED IN THE FLEXIBLE HOSE CAN BE VERY DANGEROUS. HANDLE THE FLEXIBLE HOSE CAREFULLY. DO NOT PULL THE FLEXIBLE HOSE TO MOVE THE EQUIPMENT. NEVER USE A DAMAGED OR A REPAIRED FLEXIBLE HOSE.



Take proper safety measures for the protection of hearing in case of work near the plant.



The high speed of travel of the product in the hose can create static electricity through discharges and sparks. It is suggested to earth the equipment. The pump is earthed through the earth cable of the supply.

The gun is earthed through the high pressure flexible hose.

All the conductors near the work area must be earthed.



Avoid approaching too much to the pump piston rod when the pump is working or under pressure.

A sudden movement of the piston rod can cause wounds or finger squashing.

H ANTIFREEZE SYSTEM



The machine is equipped with an anti-freeze system that allows it to work even at very low temperatures. However, after a few minutes of operation, the upper metal outer surface cools dramatically. Avoid touching the area indicated. Contact of the skin with the low-temperature area may cause frostbite. Common working clothes and leather gloves provide adequate protection.

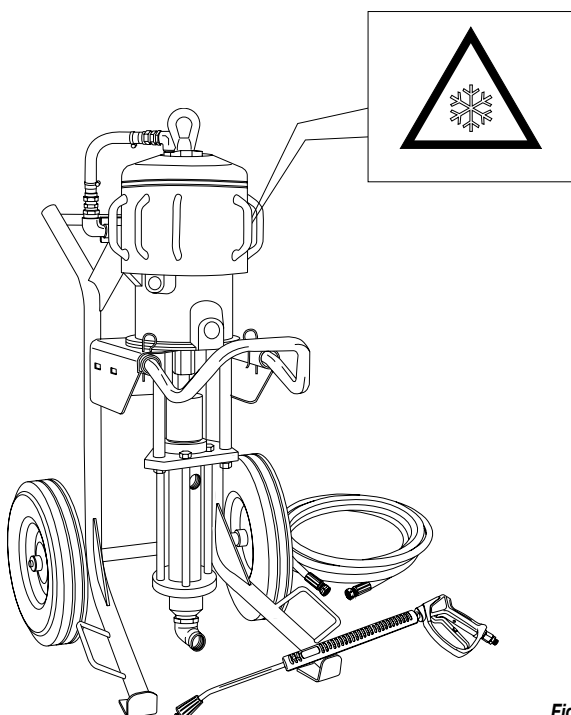

Fig. 1

In cold weather conditions it is necessary to add antifreeze liquid (1) in the FRL group (2).

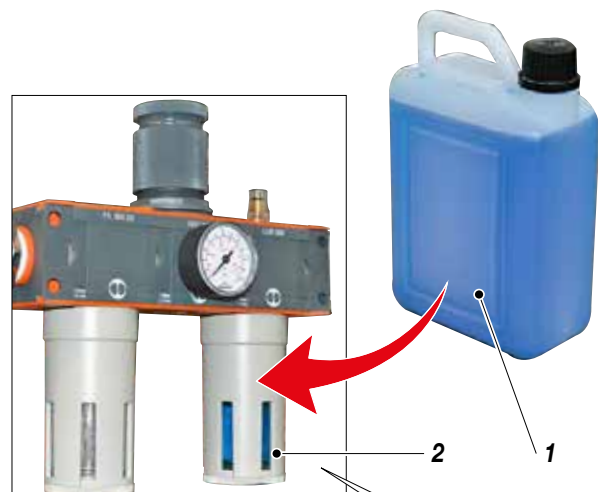
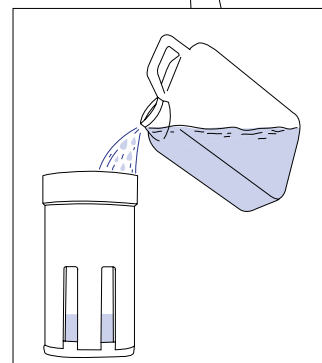

Fig. 2





If 100% pure antifreeze liquid is used, it is recommended the dilution shown in the table.

| DILUTION RECOMMENDED FOR PURE PRODUCT | | |
|---------------------------------------|-------------------------------|--|
| % water dilution | °C, environmental temperature | |
| 10% | -5 | |
| 20% | -10 | |
| 30% | -20 | |
| 40% | -25 | |
| 50% | -37 | |
| 60% | -50 | |

NOTE

When the pump is used in places with higher temperatures, the phenomenon indicated above may not occur and therefore it is not necessary to use antifreeze.

I GROUNDING

- When using volatile cleaning products, the equipment must be grounded thereby reducing the risk of static and electric shocks and providing an escape route for electrical current.
- For cleaning in closed areas, locate the pump away from any storage tanks and provide adequate ventilation.
- If flammable materials are placed in the cleaning area, take appropriate precautions to avoid sparks.

AIR AND FLUID HOSES

- use only electrically conductive hoses

SPRAY GUN/DISPENSE VALVE

- Ground through connection to a properly grounded fluid hose and pump

SOLVENT PAILS USED WHEN FLUSHING

- Use only metal pails
- Place the pail only on grounded surface
- Don't place the pail on a non-conductive surface, such as paper or cardboard, which interrupts grounding continuity

GROUNDING PUMP

- Use supplied grounding wire (1) and clamp (2)
- Connect the other end of the wire to a true earth ground (3)

MAINTAINING GROUNDING CONTINUITY DURING FLUSHING OR PRESSURE RELIEF

- Firmly hold the metal part of the spray gun / dispense valve on the side of a grounded metal pail, then activate the spray gun / dispense valve

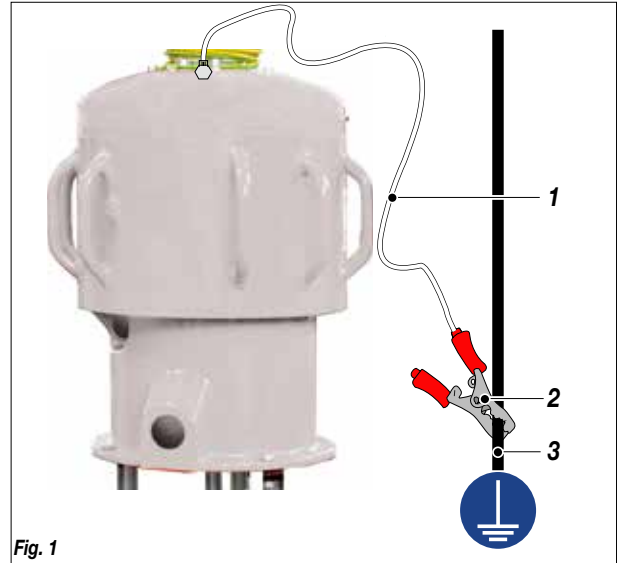

Fig. 1

J SETTING UP



Install at the pump inlet an air pressure regulator (it is suggested complete with condensate filter and lubricator). The outlet pressure of the water is 20 times the inlet pressure of the pump feed air. Therefore, it is extremely important to adjust the value of the feed air pressure.

CONNECTION OF THE MATERIAL INLET PIPE

- Connect the suction hose to the liquid inlet on the pump and to the suction pipe by tightly tightening the fittings
- Place the suction tube in the drum containing the cleaning liquid or to the water supply

CONNECTION OF THE MATERIAL OUTLET PIPE

- Connect the spray hose to the pump outlet
- Connect the spray gun to the hose

WASHING THE NEW EQUIPMENT

The pump was factory tested with light mineral oil which remained inside the lower for protection. If the fluid to be pumped is not compatible with the one used for testing, wash the pump with a suitable solution.

K WALL MOUNTING

- Ensure that the wall on which you intend to install the pump is suitable to support the weight of the pump and accessories and the stresses resulting from the use of the pump itself
- Ensure that the installation location has a space that allows easy access to the operator
- Be sure to position the bracket at an adequate height to ensure correct placement of the hoses and allow for displacement



- Firmly screw the bracket to the wall with screws and bolts suitable for the purpose
- Fix the pump to the bracket and connect the pipes as indicated in the 'SETTING UP' chapter

L WORKING



Check all the fittings for connection of the different components (pump, flexible hose, spray gun, etc.) before using the equipment.

- Dip the material pumping hose into the water tank.
- Make the compressed air flow into the pump. It is advisable to adjust air pressure to minimum necessary for its continuous working.
- When the product chamber is full, pump will start working and stopping. Pump will start working again any time the trigger of the spray gun is pressed or the delivery valve is open.
- In case of difficult suction of the pump, slowly open the bleeder valve and close it when some water comes out



Always avoid pump idling: this operation could damage the pneumatic motor and the seals.

M CLEANING AT THE END OF THE WORK

If a long period of inactivity is expected, it is advisable to suck and leave light mineral oil inside the pumping unit according to the following procedure:

- Stop the air supply to the pump.
- Immerse the pumping tube in a container containing lubricating oil, specific for a correct maintenance of the pump components.
- Make compressed air flow into the pump. It is advisable to adjust the air pressure to minimum necessary to its continuous working.
- Point the spray gun or the delivery valve at a container and drain all the liquid left inside the pump till mineral oil comes out.
- Now, stop the air supply to the pump and drain the residual pressure.

N ROUTINE MAINTENANCE



Always close the compressed air supply and release the pressure in the plant before performing any check or maintenance of the pump.

- Check periodically (and each time the pump is operated after a long storage) the packing nut (2) is not loosened, causing otherwise the coming out of the product. To tighten the packing nut, lift the wet cup (1). The packing nut (2) must be tightened so as to avoid wastes of product, but not excessively to provoke pumping piston seizure and seals wear. In case of persistent coming out of product, replace the seals.
- To prevent the product from drying up on the piston rod, refill the cup (1) with lubricant.
- Check periodically the air supply to the pump. Ensure the air is always clean and lubricated. In case of installation of a lubricator on the air supply to the pump, it is advisable to keep its cup full of a mixture of water and antifreeze liquid (dilution ratio 4:1).

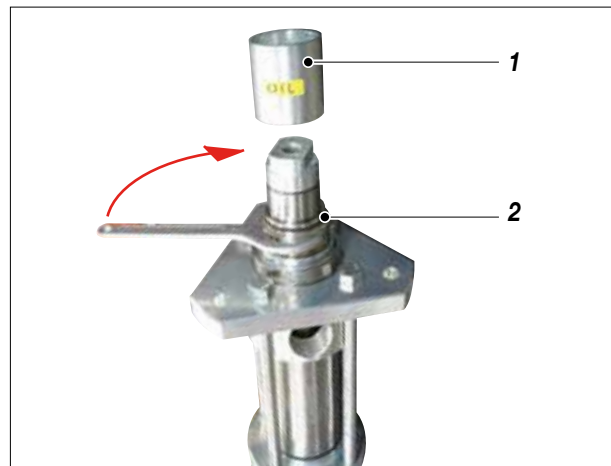

Fig. 1



Fig. 2



0 TROUBLESHOOTING

| Problem | Possible cause | Solution |
|--|---|--|
| The pump does not start | Feeding air is not enough; | Check the air supply. Increase the diameter of the feeding hose; |
| | Outlet liquid line clogged; | Clean. Disconnect the outlet liquid pipe. Feed pump at minimum pressure and check if the pump starts without the outlet pipe; |
| | Pneumatic motor blocked in the cycle reversal position; | Turn the plug counterclockwise and push downwards the valve body. Use a metal rod and a mallet; |
| | Parts failure of the pneumatic motor; | Disassemble the motor and check; |
| Accelerated working and no pressure of the pump | There is no liquid; | Add liquid; |
| | The pump sucks air; | Open the exhausting valve. For the version on air hoist, follow the instructions in the relevant manual; |
| | Feeding air is not enough; | Increase the feeding air pressure; |
| | Suction valve worn or partially clogged; | Disassemble the suction valve. Clean and/or replace if necessary the worn parts; |
| | Outlet valve worn or partially clogged; | Disassemble the outlet valve. Clean and/or replace if necessary the worn parts; |
| The pump works, but the product is not flowing enough | Suction valve worn or partially clogged; | Disassemble the suction valve. Clean and/or replace the worn parts; |
| | Outlet liquid line clogged; | Clean. Disconnect the outlet liquid pipe. Feed pump at minimum pressure and check if delivery increases without the outlet pipe; |
| | The feed air pressure is too low; | Increase air pressure; |
| Leakage of product from the lubricating cup | Upper gaskets worn. | Tighten the packing nut. In case of persistent waste of product, replace the upper gaskets of the pumping unit. |



Always close the compressed air supply and release the pressure in the plant before performing any check or replacement of parts of the pump.



P DISASSEMBLY OF THE PNEUMATIC MOTOR



Always close the compressed air supply and release the pressure in the plant before disassembling the pneumatic motor of the pump.

- Unscrew the coupling sleeve so as to disconnect the pumping group from the motor.
- Disconnect the air feeding pipe to the pump.
- Unscrew the eyebolt plug (1) and pull it upwards together with the guide rod (2).
- Hold the guide rod and remove the plug (using two wrenches).
- Replace immediately the plug with a usual M8 nut (3) before

the guide rod (2) slides into the cylinder.

- Turn counterclockwise the screws (4) take care to the washers (5) and remove the covering (6).
- Unscrew the two ring nuts (7) from the support (8).
- Turn counterclockwise the screws (9) take care to the washers (10) and remove the support (8) together with the rollers (11) and the pins (12).
- Extract the spring (13), the spring guide rod (14) and the roller pushing piston (15). Ensure the spring slides freely on the guide rod, the guide rod slides into the roller pushing piston and this last slides into the mount hole.
- Check the roller (11) and the pin (12) are undamaged. Replace them if damaged.
- Remove and check the rubber pad (16) and the washer (17).

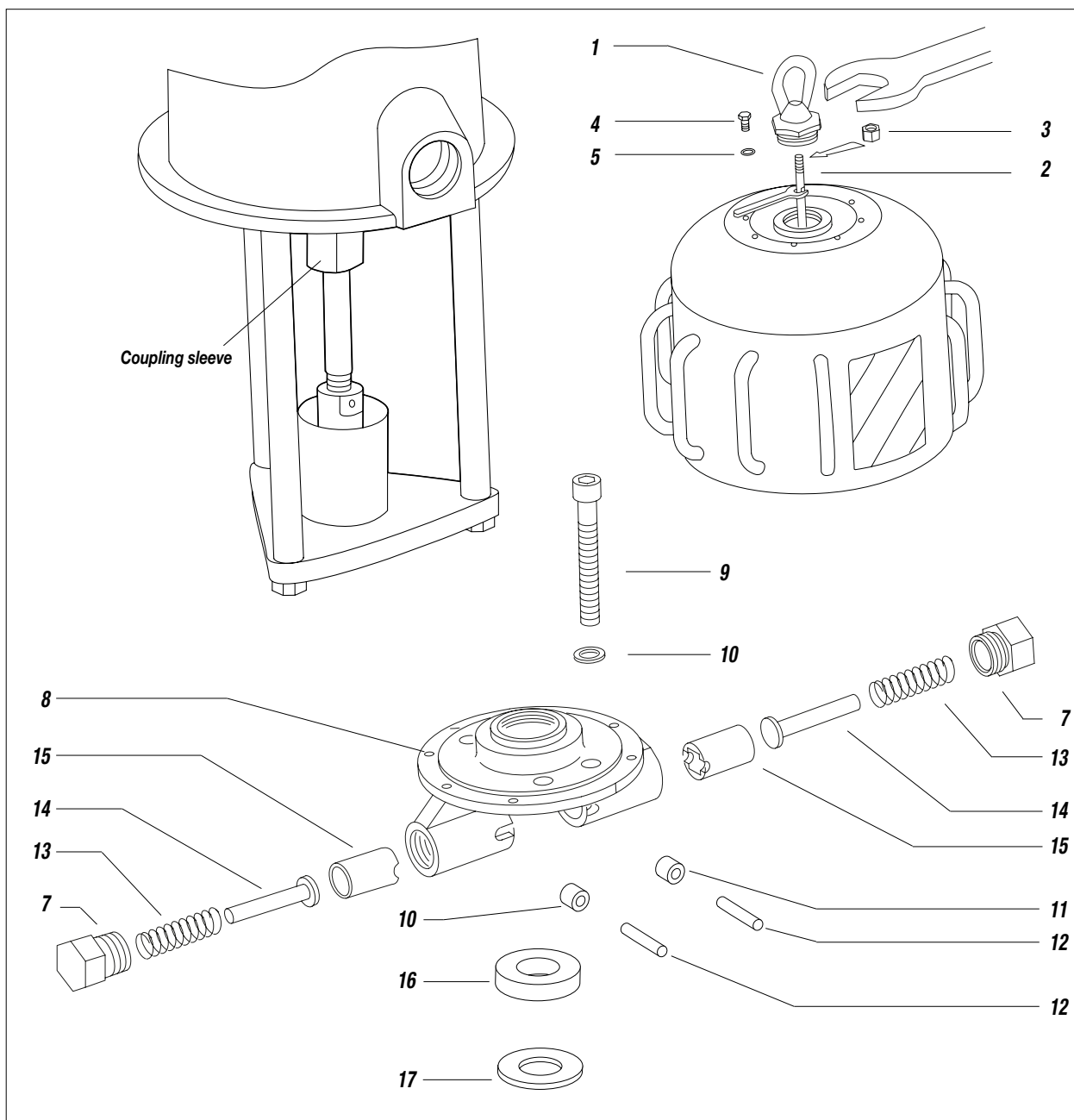

Fig. 1



- Pull upwards the seat (18) so as to take out the valves (19) and the springs (20) (clean and/or replace the worn parts).
- Unscrew the lock nut (21) [take care of the washer (22)] by keeping the bush (23) blocked using a wrench.
- Remove the seat (24) from the rod (18).
- Unscrew the bush (23) (if necessary, keep the rod (24) blocked on the threaded part using pliers with the bits wrapped in rags to avoid damage to thread).

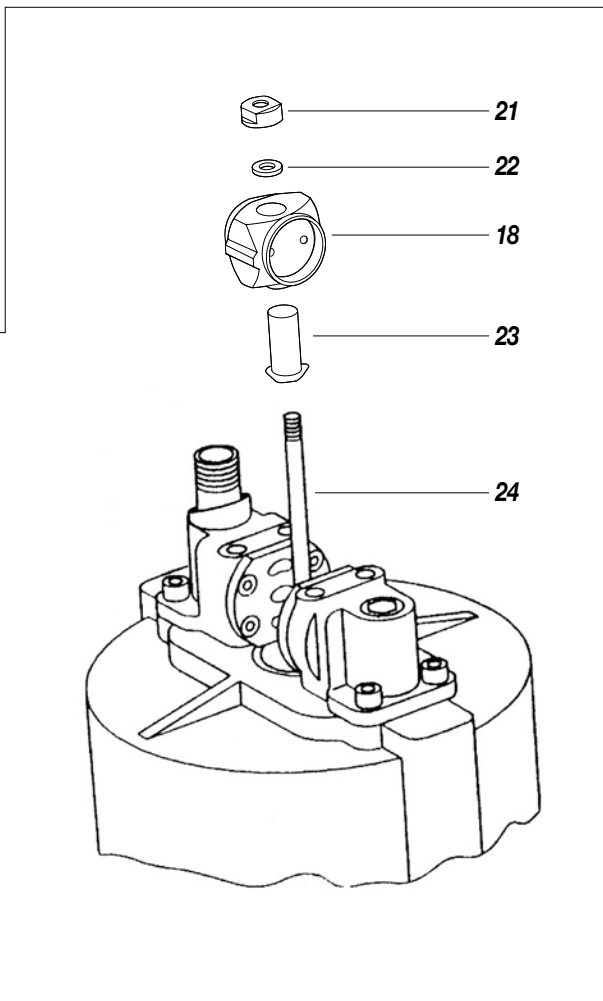
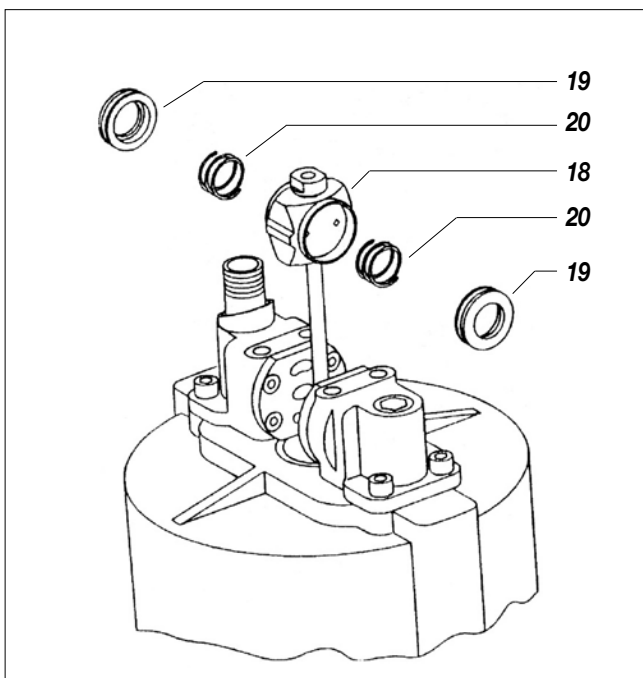

Fig. 2

- Remove the screws (25) [take care to the washers (26)], a manifold (27) and the gasket (28).

- Using a screwdriver, remove the washer (29) and the rubber pad (30).

Handle with care the manifold. The edges of its plate are very sharp.
Important: do not remove the other manifold if not necessary (it will facilitate the fastening of the manifold removed).

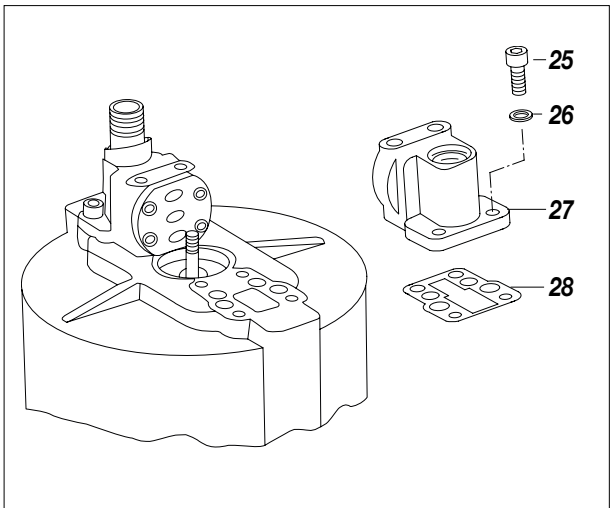

Fig. 3

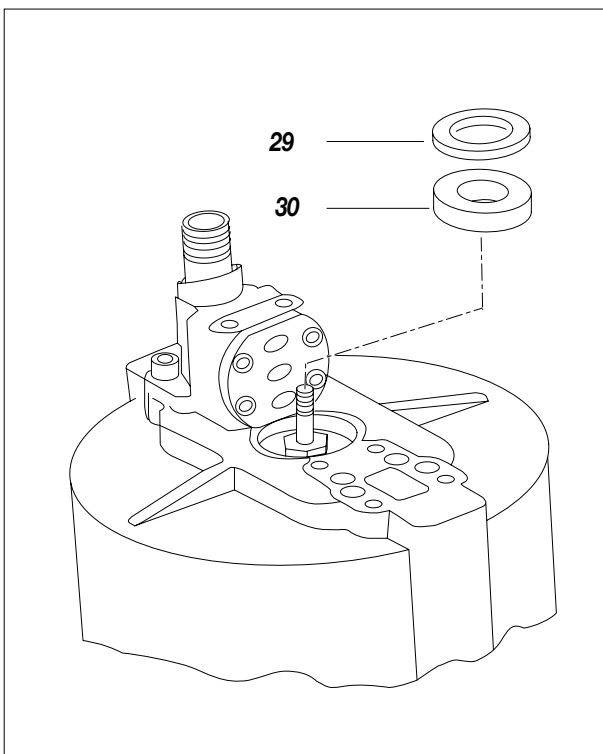

Fig. 4



- Turn counterclockwise the rod guiding screw (31) [take care to the washer (32)] and check the seal inside the screw (31) is undamaged.
- Take out the screws (33) [take care of the washers (34)] and remove carefully the cylinder (35) (do not bend it during extraction in order to avoid that motor piston may damage the internal surface of the cylinder).

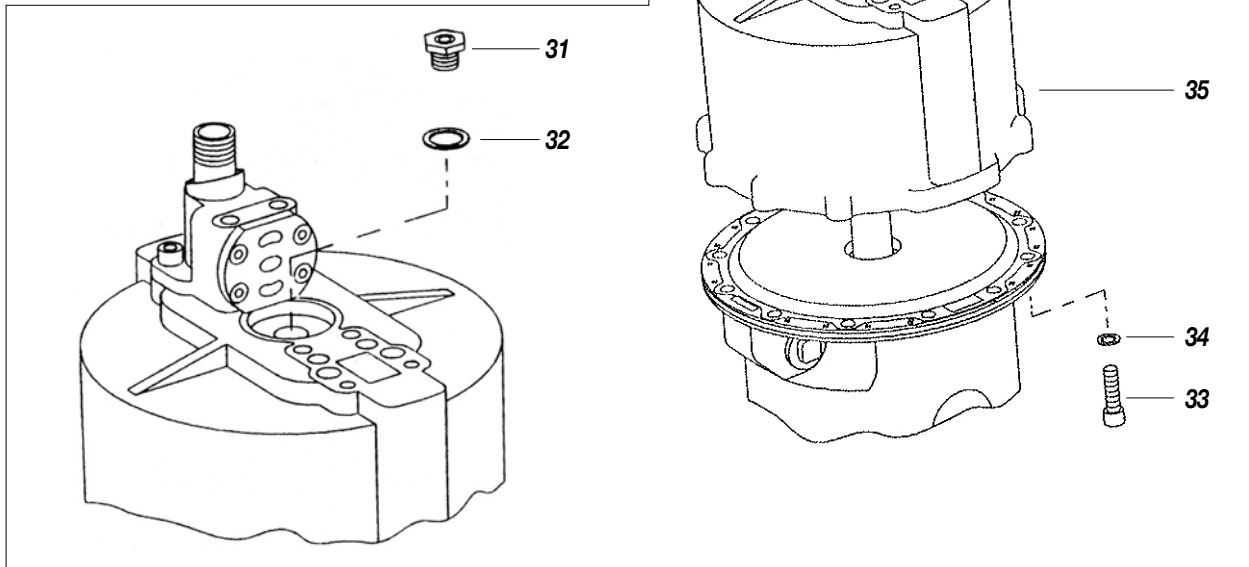

Fig. 5

- Extract the motor piston from the motor support (36).
- Verify the O-ring (37) is undamaged.
- Tighten the lower edge of the piston rod using pliers (see illustration) and unscrew the fitting (38) with a wrench.
- Remove the motor rod (39) and check it is undamaged.
- Rub the motor rod (39) with vaseline grease before inserting it into the housing of the piston rod.
- Tighten again with pliers the lower edge of the piston rod and screw the fitting (38) (application of a sealant on the thread is advisable).

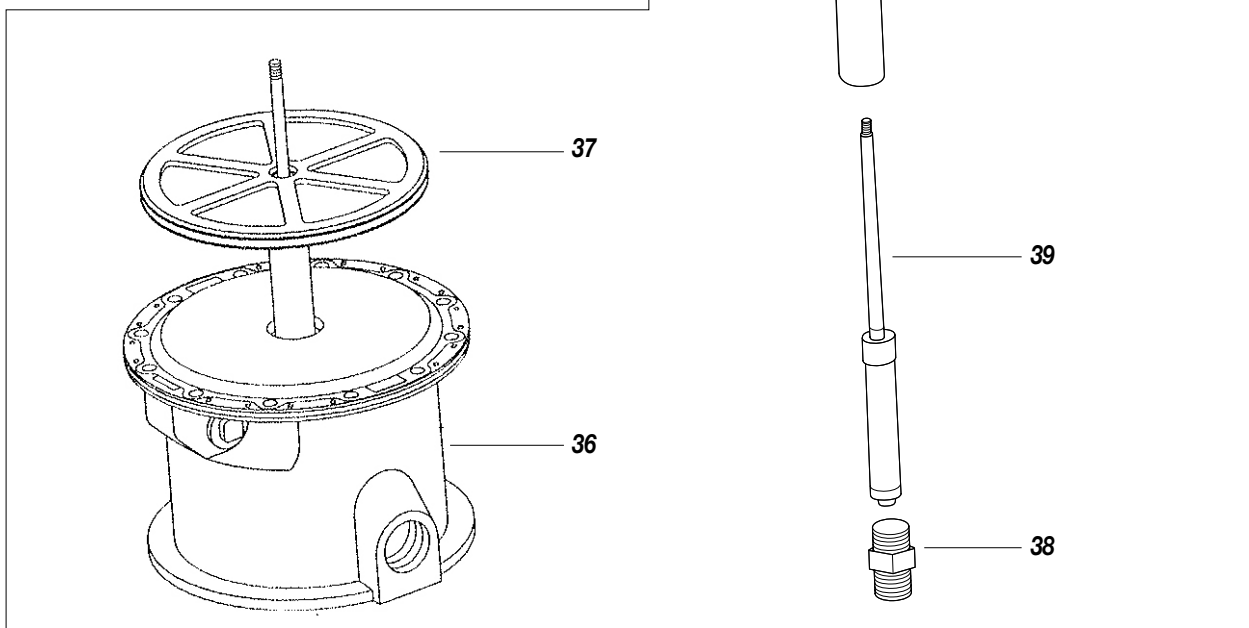

Fig. 6P



- Check the gas ring inside the support (40) is undamaged.
- Check the gasket (41) is undamaged and correctly positioned.
- Coat the inner walls of the cylinder (42) with a thin layer of vaseline grease.
- Insert the motor piston (43) into the cylinder (42) carefully.
- Fasten the cylinder (42) on the support (40) (respect the position) and at the same time insert the piston rod into the support.
- Turn clockwise the screws (44).

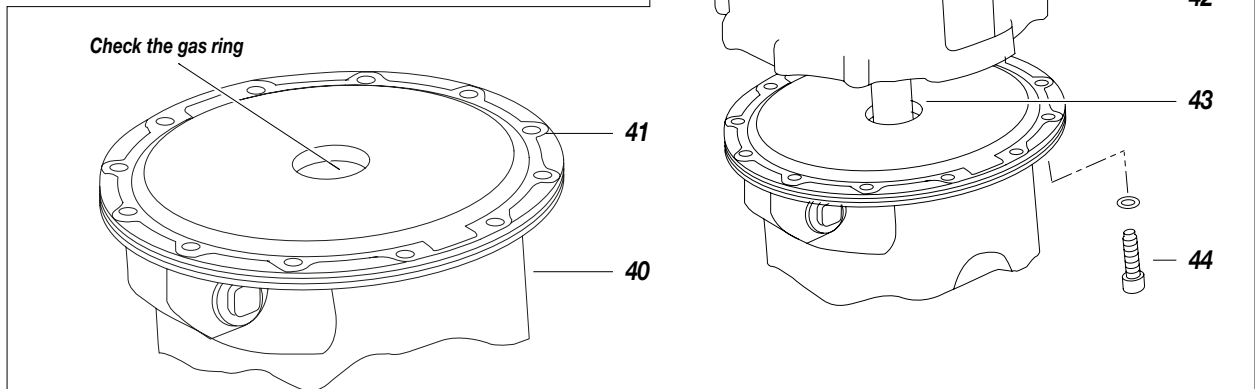

Fig. 7

- Insert into the motor rod (45) the washer (46).
- Carefully insert the rod guiding screw (47) into the motor rod (turn it slowly following the direction of the thread) and screw it on the cylinder (42).
- Insert the rubber pad (48) and the washer (49) into the support.
- Screw the bush (50) on the motor rod (45). Insert the seat (P51), the washer (52) and screw the lock nut (53).

⚠ Adjust bush and lock nut so as the rod (45) just out of about 1 mm from the lock nut (see illustration).

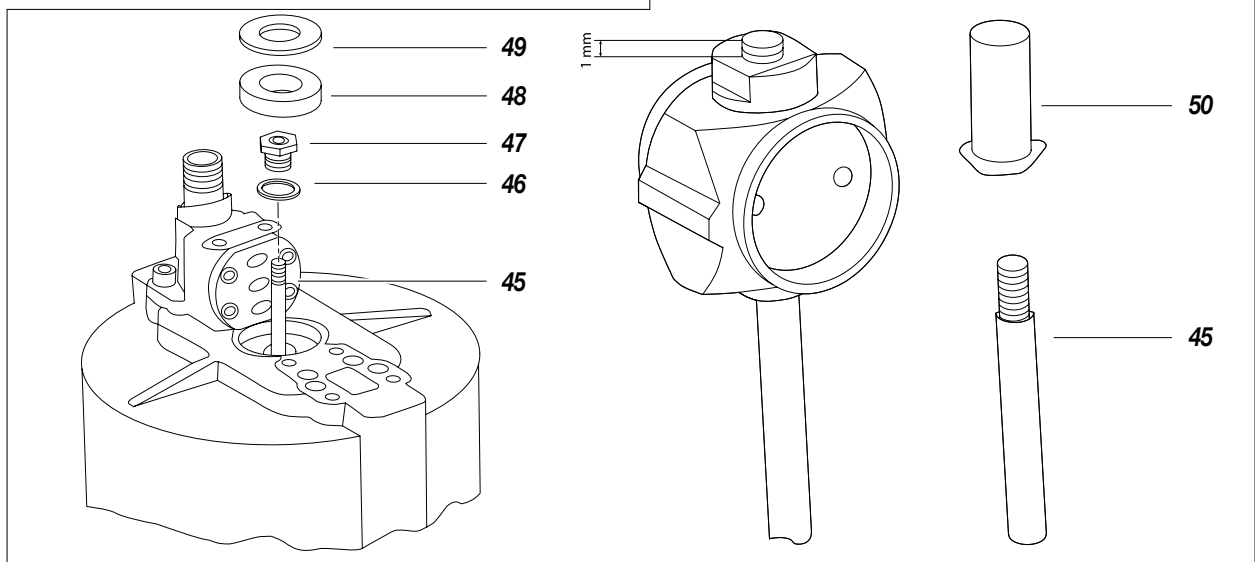

Fig. 8



- Insert the springs (55) and the valves (56) into the seat (54). Position the seat on the pump support and lay the manifold (57) on the seat [do not forget the gasket (58)].
- Fasten the manifold with screws (*do not tighten*) ensuring it is perfectly parallel to the other manifold and the distance between them is 46 mm (see illustration). The distance between the walls of the manifold and the edge of the seat must be about 0,8 mm.

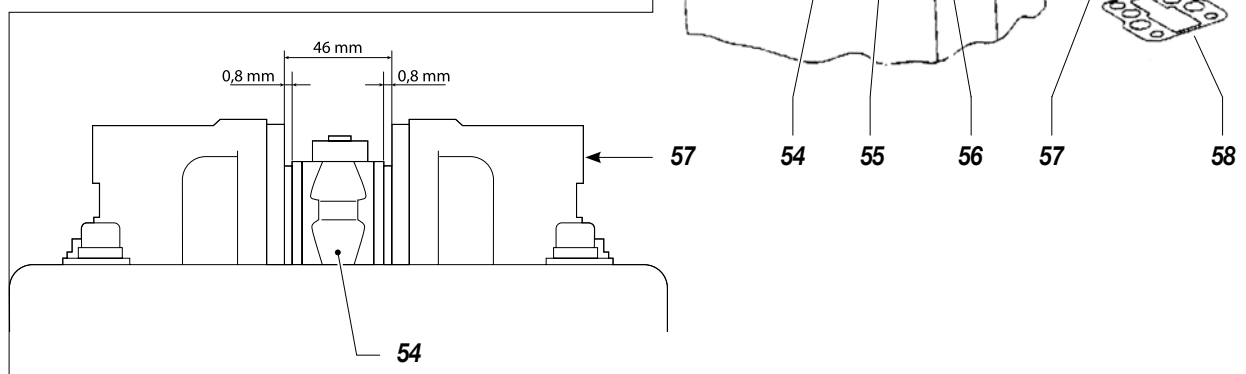

Fig. 9

- Rub the rollers (59) and the pins (60) with vaseline grease and insert them into the mount (61).
- Rub the rubber pad (62) and the washer (63) with vaseline grease and insert them into the mount (61).
- Grease the roller pushing pistons (64), the spring guide rods (65), the springs (66) and insert them into the mount (61).
- Fasten without tightening the ring nuts (67) on the mount (61).
- Fasten the mount on the manifolds and tighten the screws (69) [do not forget of washer (68)].
- Tighten the ring nuts (67) and the screws (70).
- Assemble again the covering and all the fittings of the air supply line.

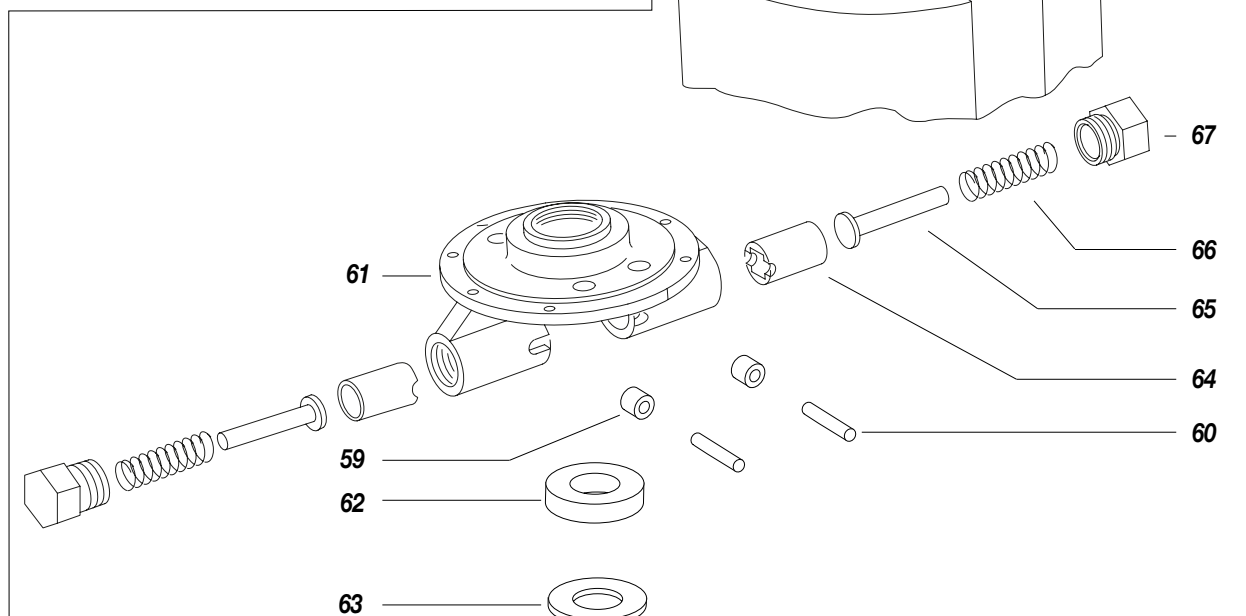

Fig. 10

Intentionally blank page



Q MOTOR GROUP SPARE PARTS

WARNING: Always indicate code and quantity for each part required.

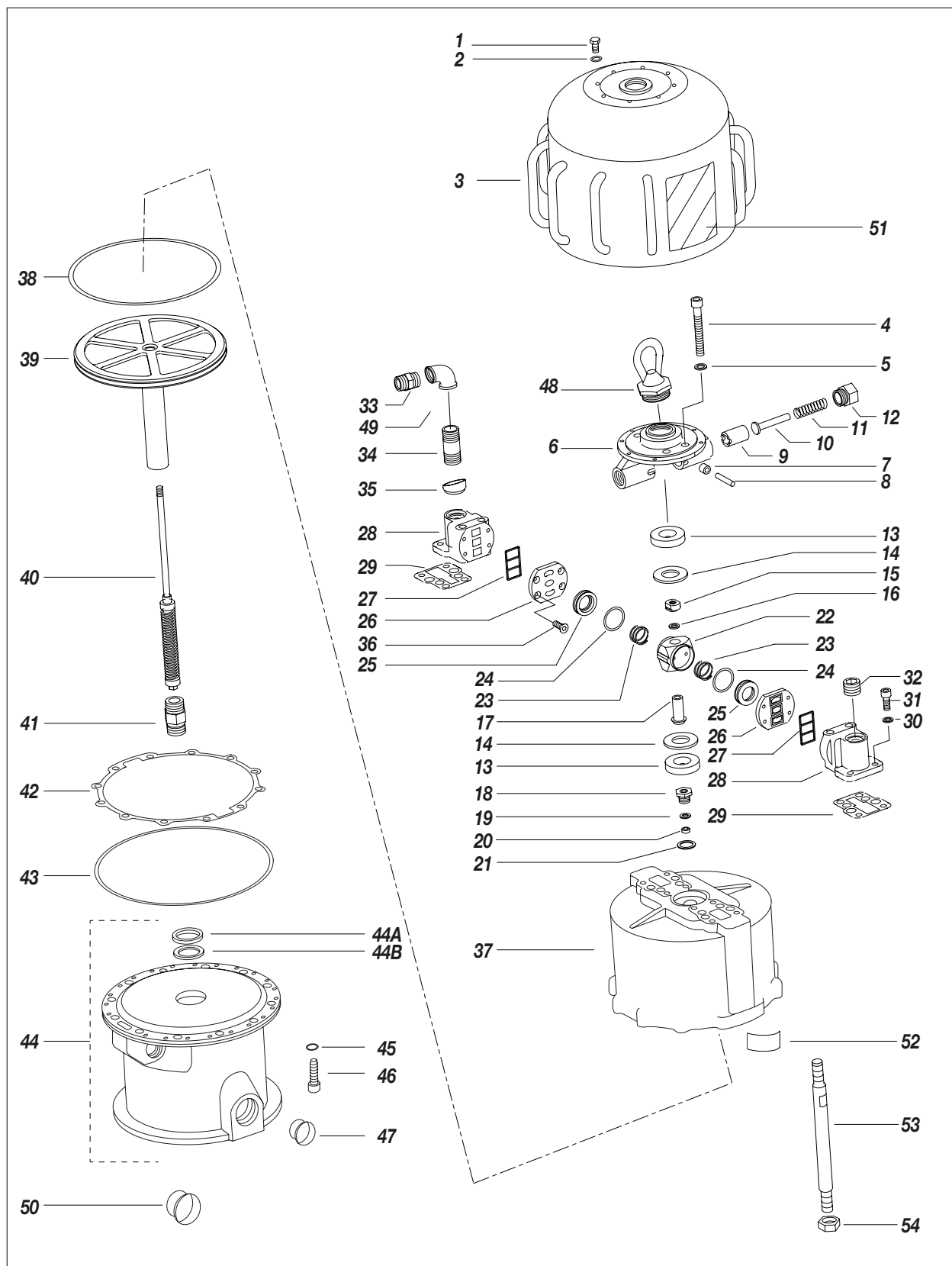



| Pos. | Code | Description | Q.ty |
|------|-------|-----------------------|------|
| 1 | 95062 | Screw | 1 |
| 2 | 95063 | Washer | 1 |
| 3 | 95064 | Covering | 1 |
| 4 | 95065 | Screw | 1 |
| 5 | 95066 | Washer | 1 |
| 6 | 95109 | Mount | 1 |
| 7 | 95092 | Roller | 1 |
| 8 | 95091 | Pin | 1 |
| 9 | 95084 | Roller pushing piston | 1 |
| 10 | 95085 | Spring guide | 1 |
| 11 | 95086 | Spring | 1 |
| 12 | 95087 | Ring nut | 1 |
| 13 | 95093 | Rubber pad | 2 |
| 14 | 95094 | Washer | 2 |
| 15 | 95095 | Lock nut | 1 |
| 16 | 95096 | Washer | 1 |
| 17 | 95098 | Bush | 1 |
| 18 | 95078 | Trip rod bearing | 1 |
| 19 | 95079 | Leather ring | 1 |
| 20 | 95080 | Seal | 1 |
| 21 | 33031 | Copper washer | 1 |
| 22 | 95097 | Valve seat | 1 |
| 23 | 95077 | Spring | 2 |
| 24 | 95075 | O-ring | 2 |
| 25 | 95076 | Valve | 2 |
| 26 | 95073 | Plate | 2 |
| 27 | 95071 | Gaskets | 2 |
| 28 | 95070 | Manifold | 2 |
| 29 | 95072 | Manifold gasket | 2 |
| 30 | 95096 | Washer | 1 |
| 31 | 95068 | Screw | 1 |

| Pos. | Code | Description | Q.ty |
|------|-------|-------------------------|------|
| 32 | 95067 | Plug 3/4" | 1 |
| 33 | 95090 | Fitting | 1 |
| 34 | 95088 | Extension | 1 |
| 35 | 95099 | Gas ring | 1 |
| 36 | 95074 | Screw | 1 |
| 37 | 95100 | Motor Cylinder | 1 |
| 38 | 95101 | O-ring | 1 |
| 39 | 95102 | Motor piston | 1 |
| 40 | 95103 | Motor rod | 1 |
| 41 | 95104 | Fitting | 1 |
| 42 | 95105 | Gasket | 1 |
| 43 | 95106 | O-ring | 1 |
| 44 | 95107 | Complete motor support | 1 |
| 44A | 3314 | Gas ring | 1 |
| 44B | 95082 | Leather ring | 1 |
| 45 | 95114 | Washer | 1 |
| 46 | 95083 | Screw | 1 |
| 47 | 95159 | Plug | 1 |
| 48 | 95061 | Eyebolt | 1 |
| 49 | 95089 | Elbow | 1 |
| 50 | 95229 | Plug | 1 |
| 51 | 95113 | Front plate | 1 |
| 52 | 95788 | Technical details plate | 1 |
| 53 | 95710 | Tie rod | 3 |
| 54 | 95013 | Nut | 3 |
| 55 | 95658 | Warning plate | 1 |
| 56 | 19256 | Atex plate | 1 |
| 57 | 95136 | Adhesive tape | 1 |
| 58 | 5010 | Grounding cable | 1 |
| 59 | 96210 | Ground plate | 1 |

| WARNING | ATTENZIONE |
|---|---|
| <p>NEVER</p> <ul style="list-style-type: none"> NEVER POINT THE SPRAY GUN AT ANYONE OR AT ANY PART OF THE BODY. NEVER EXCEED INDICATED MAXIMUM WORKING PRESSURE. NEVER SPRAY FLAMMABLE MATERIALS OR SOLVENTS INSIDE. NEVER ALLOW OF NOZZLE ANY PART OF THE EQUIPMENT. NEVER REPAIR THE EQUIPMENT WHEN IT IS UNDER PRESSURE. NEVER ALLOW ANOTHER PERSON TO USE THE EQUIPMENT UNLESS HE IS THOROUGHLY INSTRUCTED ON ITS USE AND OPERATION. <p>ALWAYS</p> <ul style="list-style-type: none"> ALWAYS READ INSTRUCTIONS MANUAL. ALWAYS USE APPROVED HIGH PRESSURE FLUID HOSE. ALWAYS CONNECT TO THE AIRGAS OF THE EQUIPMENT AND THE OBJECTS TO BE TREATED. ALWAYS CHECK ALL THE FLUID CONNECTIONS AMONG THE PUMP THE FLUID HOSE AND THE SPRAY GUN. | <p>MAI</p> <ul style="list-style-type: none"> NON SPINGERE MAI LA PISTOLA VERSO SE STESSI O ALTRA PERSONA. NON SUPERARE MAI LE PRESSIONI MASSIME DI ESERCIZIO INDICATE. NON SPRIZZARE MAI SOSTANZE INFIAMMABILI O SOLVENTI IN AMBIENTI CHIUSI. NON RIPARARE MAI NESSUN PARTICOLARE DELL'APPARECCHIATURA. NON RIMPIEDIRE MAI L'APPARECCHIATURA QUANDO È SOTTO PRESSIONE. NON PERMETTERE MAI AD UN'ALTRA PERSONA DI USARE L'APPARECCHIATURA SE NON DOPO ADEGUATE ISTRUZIONI. <p>SEMPRE</p> <ul style="list-style-type: none"> LEGGERE SEMPRE IL MANUALE D'USO. USARE SEMPRE TUBO E FLUIDO, UN TUBO ALTA PRESSIONE CHE SIA CONFORME. COLLEGARE SEMPRE A TERRA L'APPARECCHIATURA E GLI OGGETTI DA TRATTARE. CONTROLLARE SEMPRE TUTTI I RACCORDI DI COLLEGAMENTO TRA POMPA, TUBO FLUIDO E PISTOLA. |

LARIUS
Calozziocorte (LC)

POMPA A PISTONE PER TRAVASO TRANSFER PNEUMATIC PISTON PUMP

CE SERIE NOVA **Ex**

II 2 G c IIB T6

T_{amb.} : -20°C ÷ +60°C T_{max.fluido} : 90°C*

Tech. file: NOVA/ATX/08

* water or based water products



57



58

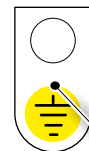

59

**GASKETS KIT MOTOR -
CODE 40065**

| Pos. | Description | Q.ty |
|------|-----------------|------|
| 19 | Leather ring | 1 |
| 20 | Seal | 1 |
| 21 | Copper washer | 1 |
| 24 | O-ring | 2 |
| 25 | Valve | 2 |
| 29 | Manifold gasket | 2 |
| 38 | O-ring | 1 |
| 42 | Gasket | 1 |
| 43 | O-ring | 1 |
| 44A | Gas ring | 1 |
| 44B | Leather ring | 1 |

**MOTOR MOVEMENT INVERSION DEVICE -
CODE 40066**

| Pos. | Description | Q.ty |
|------|-----------------------|------|
| 7 | Roller | 2 |
| 8 | Pin | 2 |
| 9 | Roller pushing piston | 2 |
| 24 | O-ring | 2 |
| 25 | Valve | 2 |
| 29 | Manifold gasket | 2 |

Intentionally blank page



R PUMPING GROUP SPARE PARTS

WARNING: Always indicate code and quantity for each part required.

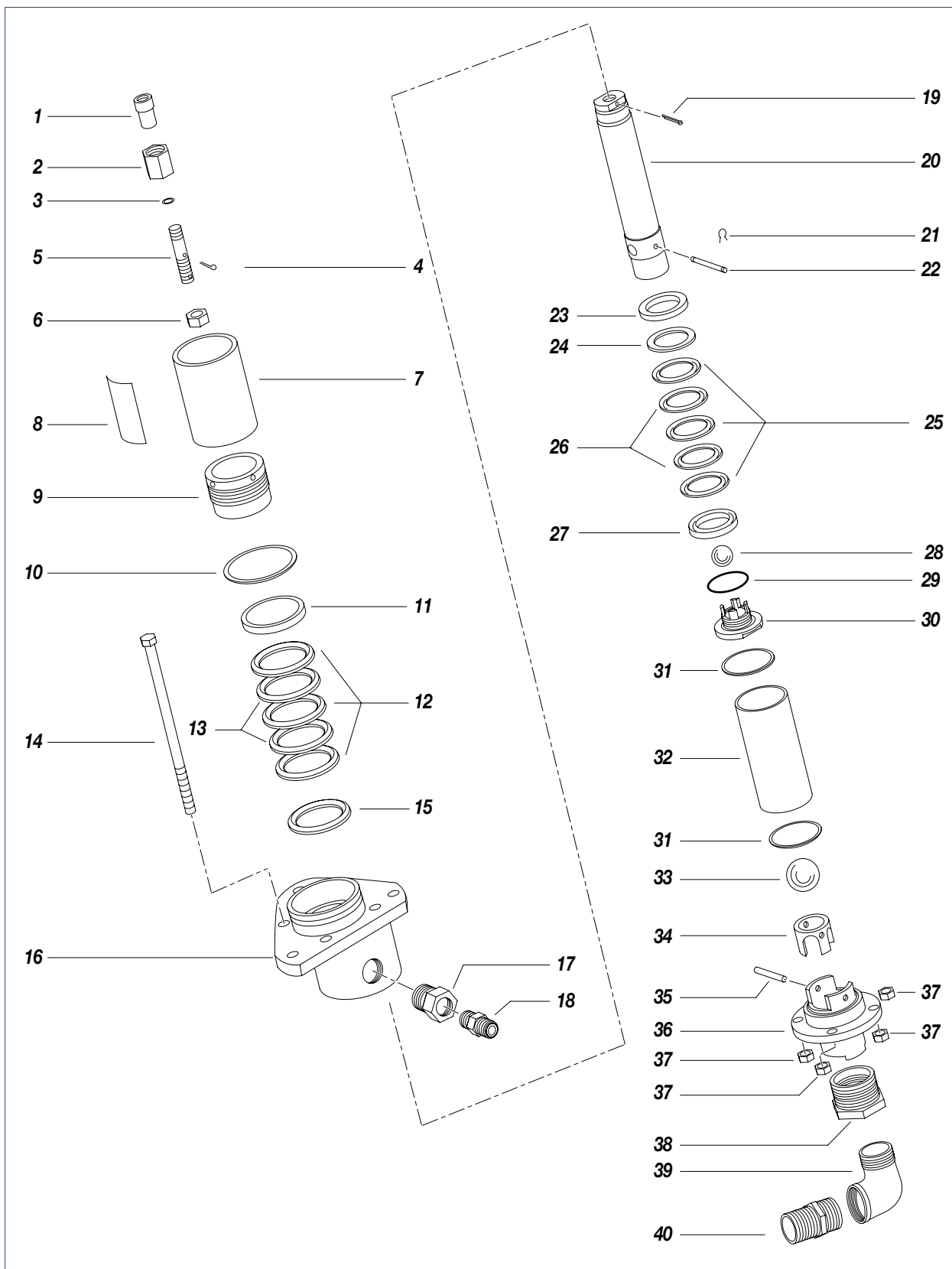



| Pos. | Code | Description | Q.ty |
|------|---------|-----------------------------|------|
| 1 | 95003 | Bush | 1 |
| 2 | 95004 | Sleeve | 1 |
| 3 | 95005 | O-ring | 1 |
| 4 | 95015 | Split pin | 1 |
| 5 | 95006 | Tie rod | 1 |
| 6 | 95007 | Nut | 1 |
| 7 | 95008/1 | Oil bucket | 1 |
| 8 | 96233 | 'Oil' label | 1 |
| 9 | 98305 | Gasket ring nut | 1 |
| 10 | 95008/3 | O-ring | 1 |
| 11 | 95767 | Stainless steel female ring | 1 |
| 12 | 95803 | PTFE gasket | 3 |
| 13 | 95803/2 | Gasket | 2 |
| 14 | 95622 | Tie rod | 4 |
| 15 | 95766 | Stainless steel male ring | 1 |
| 16 | 95790 | Upper gasket housing | 1 |
| 17 | 3558/1 | Reduction | 1 |
| 18 | 6149 | Nipple | 1 |
| 19 | 95753 | Split pin | 1 |
| 20 | 98720 | Stem | 1 |

| Pos. | Code | Description | Q.ty |
|------|---------|-----------------------------|------|
| 21 | 98706 | Seeger | 2 |
| 22 | 98726 | Ball stop pin | 1 |
| 23 | 95793 | Washer | 1 |
| 24 | 98722 | Stainless steel male ring | 1 |
| 25 | 95810 | PTFE gasket | 3 |
| 26 | 95810/2 | Gasket | 2 |
| 27 | 98723 | Stainless steel female ring | 1 |
| 28 | 95642 | Ball 7/8" | 1 |
| 29 | 95807 | O-ring | 1 |
| 30 | 98727 | Complete valve fitting | 1 |
| 31 | 95722 | Washer | 2 |
| 32 | 98718 | Sleeve | 1 |
| 33 | 95027 | Ball 1" 1/4 | 1 |
| 34 | 95794 | Guide ball | 1 |
| 35 | 98719 | Ball stop pin | 1 |
| 36 | 95791 | Lower housing | 1 |
| 37 | 95013 | Nut | 4 |
| 38 | 98230 | Reduction | 1 |
| 39 | 98231 | Elbow M/F | 1 |
| 40 | 8373/2 | Nipple | 1 |

S COMPLETE TROLLEY

WARNING: Always indicate code and quantity for each part required.

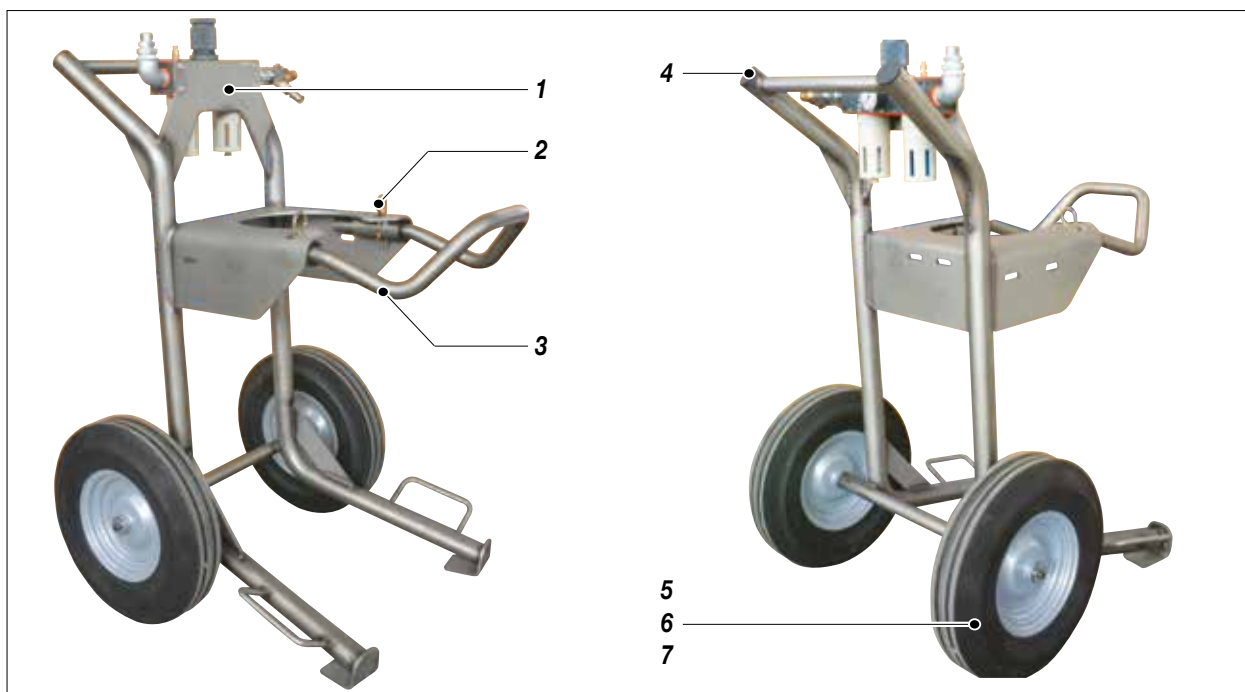

| Pos. | Code | Description | Q.ty |
|------|---------|------------------|------|
| | 65380/1 | Complete trolley | |
| 1 | 65381/1 | Trolley | 1 |
| 2 | 180902 | Split pin | 2 |
| 3 | 65382/1 | Trolley handle | 1 |

| Pos. | Code | Description | Q.ty |
|------|--------|-------------|------|
| 4 | 20304 | Plug | 2 |
| 5 | 4461/1 | Wheel | 2 |
| 6 | 65383 | Bushing | 2 |
| 7 | 96031 | Screw | 2 |

T AIR GROUP SPARE PARTS - TROLLEY VERSION Cod. 95145

WARNING: Always indicate code and quantity for each part required.

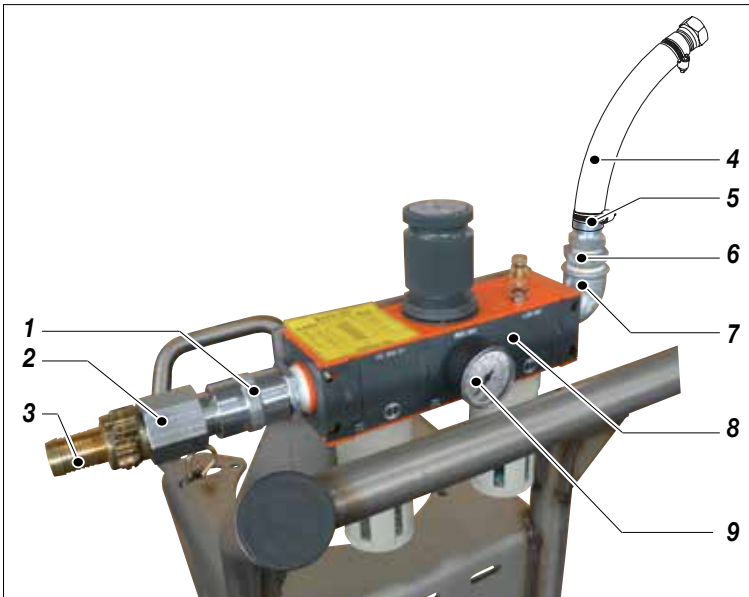

| Pos. | Code | Description | Q.ty |
|------|--------|-----------------------|------|
| | 95145 | Air group spare parts | |
| 1 | 95323 | Valve | 1 |
| 2 | 95302 | Quick coupling | 1 |
| 3 | 95301 | Quick coupling | 1 |
| 4 | 510142 | Pneumatic supply hose | 1 |
| 5 | 95090 | Nipple | 1 |
| 6 | 95313 | Reduction | 1 |
| 7 | 95031 | Elbow M/F | 1 |
| 8 | 95350 | F.R.L. 300 group | 1 |
| 9 | 96259 | Manometer | 1 |

U AIR GROUP SPARE PARTS - WALL VERSION Cod. 95145/1

WARNING: Always indicate code and quantity for each part required.

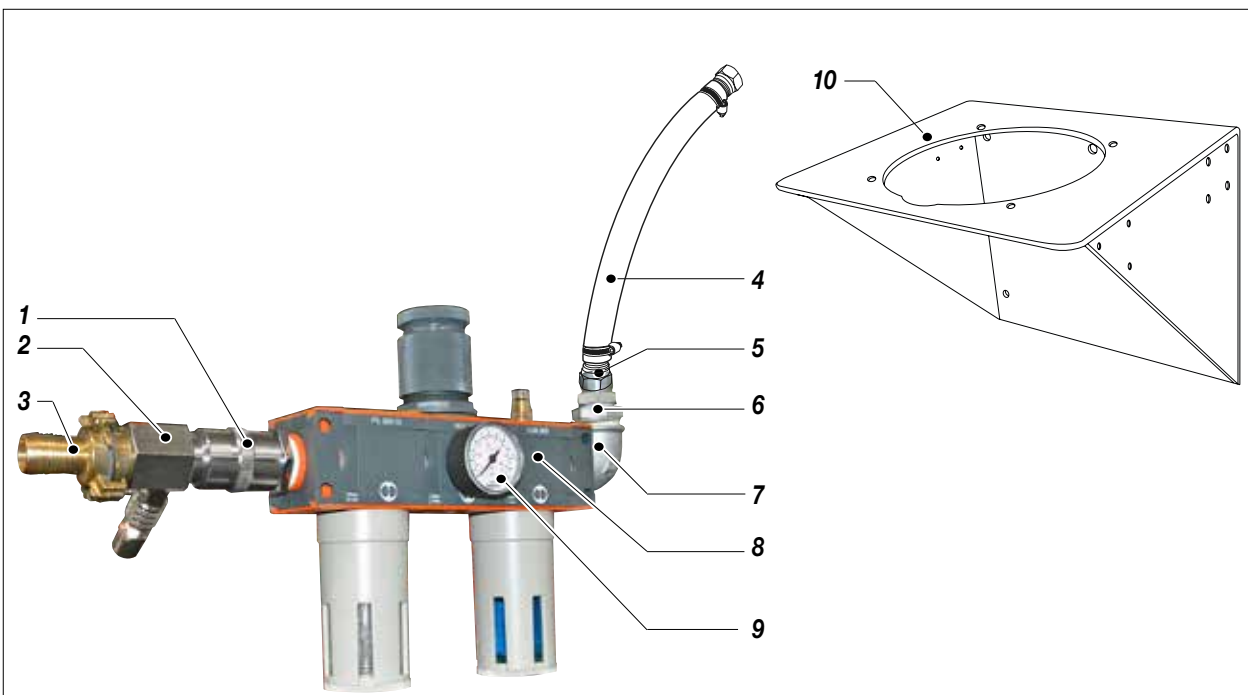

| Pos. | Code | Description | Q.ty |
|------|---------|-----------------------|------|
| | 95145/1 | Air group spare parts | |
| 1 | 95323 | Valve | 1 |
| 2 | 95302 | Quick coupling | 1 |
| 3 | 95301 | Quick coupling | 1 |
| 4 | 510143 | Pneumatic supply hose | 1 |
| 5 | 95090 | Nipple | 1 |

| Pos. | Code | Description | Q.ty |
|------|-------|------------------|------|
| 6 | 95313 | Reduction | 1 |
| 7 | 95031 | Elbow M/F | 1 |
| 8 | 95350 | F.R.L. 300 group | 1 |
| 9 | 96259 | Manometer | 1 |
| 10 | 95043 | Wall support | 1 |



V ACCESSORIES

WARNING: Always indicate code and quantity for each part required.

| Code | Description |
|---------|--|
| 70008 | Gun with 170 cm extension with fitting BSPP 3/8" |
| 18072/1 | Hose 15 mt with fitting BSPP 1" |
| 70150 | Stainless steel suction filter 200 lt with fitting BSPP 1" |
| 70155 | NOVA pneumatic washing pumps series filter |
| 6149/2 | Nipple MM with fitting BSPP 3/8" |
| 65016 | Double outlet kit with fitting BSPP 3/8" |
| 98245 | Suction tube for tank 30 lt with fitting BSPP 1" |
| 98246 | Suction tube for tank 1000 lt with fitting BSPP 1" |

W ATEX CERTIFICATION

DESCRIPTION

These safety instructions refer to the installation, use and maintenance of **NOVA** series pneumatic piston transfer pumps in high risk environments where potentially explosive gasses or vapours are present.



These instructions, along with the indications provided in the user and maintenance manual, must be fully respected.



The **NOVA** series pneumatic piston pumps are group II mechanical devices for use in areas where gasses classified as iib (*category 2 g*) are present. They are designed and built in accordance with the 94/9/Ec ATEX Directive, based on the following european standards: EN 1127-1, EN 13463-1 and EN 13463-5.

TECHNICAL CHARACTERISTICS

The main characteristics of the NOVA series pneumatic piston pumps are provided in the table below:

| Rate | Pressure alimentation | Ø Air Inlet | Input material | Ø Output material | Max. working pressure | Max. flow |
|------|-----------------------|-------------|----------------|-------------------|-----------------------|-----------|
| 20:1 | 3 ÷ 6 bar | BSPP 3/4" | Ball | BSPP 1. 1/2" | 120 bar | 32 l/min |
| 30:1 | 3 ÷ 6 bar | BSPP 3/4" | Ball | BSPP 3/8" | 210 bar | 23 l/min |
| 45:1 | 3 ÷ 6 bar | BSPP 3/4" | Ball | BSPP1. 1/2" | 270 bar | 14 l/min |
| 55:1 | 3 ÷ 6 bar | BSPP 3/4" | Shovel plate | BSPP1" | 330 bar | 12 l/min |
| 60:1 | 3 ÷ 6 bar | BSPP 3/4" | Ball | BSPP 1" | 360 bar | 12 l/min |
| 68:1 | 3 ÷ 6 bar | BSPP 3/4" | Ball | BSPP 3/4" | 410 bar | 11 l/min |

Maximum number of cycles per minute: 60 Room temperature: -20°C to +60°C Max. fluid temperature (water) [°C]: 90°C*

MARKINGS

CE  **II 2 G c IIB T6** • T_{amb}: -20°C ÷ + 60°C • T_{max. fluid (water)}: 90°C* • Tech. File: NOVA/ATX/08

| | |
|------------------------|---|
| II = | Group II (surfaces) |
| 2 = | Category 2 (zone 1) |
| G = | Explosive atmosphere containing gasses, vapours or mists |
| c = | Design safety "c" |
| T6 = | Temperature class T6 |
| - 20°C ÷ + 60°C | Room temperature |
| 90°C | Maximum process fluid temperature (water or based water products) |
| xxxx/AA | Serial number or lot number (xxxxx = PROGRESSIVE / year = AA) |



NOTE

* Fluid temperature can be 90° maximum only with water or water based products



Correspondence between hazardous areas, substances and categories

| HAZARDOUS AREAS | | CATEGORIES ACCORDING TO THE 94/9/CE DIRECTIVE |
|--------------------------|--------|---|
| Gasses, vapours or mists | Zone 0 | 1G |
| Gasses, vapours or mists | Zone 1 | 2G or 1G |
| Gasses, vapours or mists | Zone 2 | 3G, 2G or 1G |

SAFETY INSTRUCTIONS FOR INSTALLATION IN HAZARDOUS AREAS



Read the indications provided in the user and maintenance manual carefully prior to installation. All of the maintenance operations must be performed according to the indications provided in the manual.

- The grounding wire for the pumps indicated above must be grounded using an appropriate anti-loosening connection.
- The tubes used to connect the delivery and suction lines must be either metallic, plastic with metallic braid, or plastic with fabric braid and a suitable grounding conductor.
- The pumps must be installed on properly grounded metallic or antistatic drums.
- The gases or vapours of any flammable liquids present must belong to group IIB.
- Based on the type of use and the substances employed, the user must periodically check for any encrustations and must verify the cleanliness, the wear status and the correct functionality of the pump on a regular basis.
- The user must periodically clean the suction filter in order to prevent any solid materials from entering the pump. The air used to power the pump must be filtered and must come from a SAFE AREA.



NOVA series pneumatic piston transfer pump cannot work without material. All of the installation and maintenance operations must be performed by qualified personnel.

We Larius S.r.l.
Via Stoppani, 21
23801 Calolziocorte (LC)

declare under our sole responsibility that the product:

NOVA series pneumatic piston transfer pump.

to which this declaration relates complies with the following directives:

- Directive 94/9/EC (ATEX)

The conformity are under observance of the following standards

or standards documents:

- EN 1127-1 - EN 13463-5
- EN 13463-1

Markings

CE II 2G c IIB T6 Tamb.: -20°C ÷ 60°C Tmax. fluid(water): 90°C*

Tech. File: NOVA/ATX/08

Technical dossier kept on file c/o: INERIS (0080)

Calolziocorte- LC, 15/12/2008

Signature (LARIUS)

*water or based water products



Appareil non électrique destiné à être utilisé en atmosphères explosibles
Non electrical equipment intended for use in potentially explosive atmospheres
Apparecchi destinati ad essere utilizzati in atmosfera potenzialmente esplosiva

Directive 2014/34/UE
Directive 2014/34/EU / Direttiva 2014/34/UE

ACCUSÉ DE RECEPTION D'UN DOSSIER TECHNIQUE
ACKNOWLEDGE RECEIPT OF TECHNICAL DOCUMENTATION
AVVISO DI RICEVIMENTO DEL FASCICOLO TECNICO

Appareil / Equipment / Apparecchiatura :

PNEUMATIC TRANSFER & EXTRUSION PUMPS

Type(s) / Type(s) / Tipo(i) : **Series NOVA**

Marquage / Marking / Marcatura :



Dépositaire / Applicant / Richiedente : **LARIUS S.r.l.**
Via Stoppani, 21

I- 23801 Calolziocorte (LC)

L'INERIS, organisme notifié et identifié sous le numéro 0080, conformément aux articles 17 et 21 de la Directive du Conseil 2014/34/UE du 26 février 2014, accuse réception du dossier conformément à la procédure décrite au chapitre 3, article 13 1) b) ii) de la Directive.

INERIS, notified body and identified under number 0080, in accordance with articles 17 and 21 of Council Directive 2014/34/EU of the 26 february 2014, acknowledges receipt of file according to the procedure described chapter 3, article 13 1) b) ii) of the Directive.

L'INERIS, organismo notificato e identificato con il n.0080 conformemente agli articoli 17 e 21 della Direttiva 2014/34/UE del Consiglio dell'Unione Europea del 26 febbraio 2014, conferma il ricevimento del fascicolo in conformità alla procedura prevista nella rubrica 3, articolo 13 1) b) ii) della Direttiva.

La documentation technique référencée : **NOVA/ATX/08 dated 2008-12-15**

The technical documentation referenced : **NOVA/ATX/08 dated 2008-12-15**

La documentazione tecnica di riferimento : **NOVA/ATX/08 dated 2008-12-15**

est consignée sous le numéro d'enregistrement :

is consigned under the reference :

è depositata con il numero di registrazione :

n° INERIS-EQEN 021759/19.

no INERIS-EQEN 021759/19.

n° INERIS-EQEN 021759/19.

Dans le cadre de cet enregistrement, l'INERIS n'a pas examiné le contenu de la documentation technique.

Within the scope of the recording, INERIS did not examine the content of the technical documentation.

Nel quadro di questa registrazione, INERIS non ha esaminato il contenuto della documentazione tecnica.

Date de fin de validité : **2029.03.11**

Validity completion date : **2029.03.11**

Data di fine di validità : **2029.03.11**

Verneuil-en-Halatte, le **2019.03.11**



Le Directeur Général de l'INERIS,
Par délégation,

The Chief Executive Officer of INERIS,
Thierry HOUEIX By delegation,
Délégué Certification ATEX
Ex Certification Officer

Il Direttore generale dell' INERIS,
Per Delega,

Ce document ne peut être reproduit que dans son intégralité / Only the entire document may be reprinted / Questo documento può essere riprodotto solo integralmente

Parc Technologique Alata BP 2 F-60550 Verneuil-en-Halatte
tél +33(0)3 44 55 66 77 fax +33(0)3 44 55 66 99 internet www.ineris.fr
Institut national de l'environnement industriel et des risques

Etablissement public à caractère industriel et commercial - RCS Compiègne B 381 984 924 - Siret 381 984 921 00019 - APE 7120B - TVA Intracom FR 73 381 984 921

IM-140316B - mise en application : 20/04/2016

Intentionally blank page



CE DECLARATION OF CONFORMITY



Company



LARIUS srl
Via Antonio Stoppani 21 - 23801 Calolziocorte (LC) ITALY
Tel: +39 0341 621152
Fax: +39 0341 621243
E-mail: larius@larius.com

Declares under his owns responsibility that the product:

NOVA 20:1 PNEUMATIC WASHING PUMP Pneumatic airless pump

complies with the directives: | - EC Directive 2006/42 Machinery Directive

furthermore to the
harmonized standards: | - UNI EN ISO 12100-1/-2
Machinery safety, basic concepts, general principles of design. Basic
terminology, methodology. Technical principles.

This declaration relates exclusively to the product in the state in which it was placed on the market, and excludes components or modifications which are added or carried out subsequently by end user.

Calolziocorte, 19 January 2024
Place / Date

Signature



Pierangelo Castagna
Managing Director



**SAMOA INDUSTRIAL, S.A. - HEADQUARTERS
SPAIN AND EXPORT MARKETS**

POL. IND. PORCEYO, I-14 - CAMINO DEL FONTÁN, 831
E-33392 GIJÓN (ASTURIAS), SPAIN
TEL.: +34 985 381 488 - FAX: + 34 985 147 213

**SAMOA S.A.R.L.
FRANCE**

P.A.E.I. DU GIESSEN
3, RUE DE BRISCHBACH
67750 SCHERWILLER, FRANCE
TEL.: +33 3 88 82 79 62 - FAX: +33 3 88 82 77 88

**SAMOA ITALIA - LARIUS
ITALY**

VIA ANTONIO STOPPANI,21
23801 CALOLZIOCORTE (LC) ITALY
Tel.: +39 0341 621152 - Fax: + 39 0341 621242

SAMOA FLOWTECH GMBH

GERMANY, AUSTRIA, SWITZERLAND, THE NETHERLANDS AND GREECE
AM OBEREICHHOLZ 4
D - 97828 MARKTHEIDENFELD, GERMANY
TEL.: +49 9391 9826 0 - FAX: +49 9391 98 26 50

SAMOA LTD.

UNITED KINGDOM AND REP. OF IRELAND

ASTURIAS HOUSE - BARRS FOLD ROAD
WINGATES INDUSTRIAL PARK
WESTHOUGHTON, BL5 3XP, UK
TEL.: +44 1942 850600 - FAX: +44 1942 812160



SAMOA CORPORATION

USA AND CANADA
90 MONTICELLO ROAD
WEAVERVILLE, NC 28787, USA
TEL. +1 (828) 645-2290 - FAX: +1 (828) 658 0840



©Copyright, SAMOA INDUSTRIAL, S.A.
SAMOA Industrial, S.A. is an ISO 9001, ISO 14001 and ISO 45001 certified company.

»»» Contact us today!
Visit www.samoaindustrial.com for more information.

| OPERATING AND MAINTENAINCE MANUAL AVAILABLE IN: | | |
|---|----|---|
|  | IT | https://www.larius.com/wp-content/uploads/NOVA_20_1_WASH_PUMP_I.pdf |
|  | EN | https://www.larius.com/wp-content/uploads/NOVA_20_1_WASH_PUMP_UK.pdf |
|  | ES | https://www.larius.com/wp-content/uploads/NOVA_20_1_WASH_PUMP_ES.pdf |