

www.larius.com

Airless line marker with piston pump

Excalibur liner



IT	https://www.larius.com/wp-content/uploads/EXCALIBUR_LINER_I.pdf
EN	https://www.larius.com/wp-content/uploads/EXCALIBUR_LINER_GB.pdf
DE	https://www.larius.com/wp-content/uploads/EXCALIBUR_LINER_D.pdf
FR	https://www.larius.com/wp-content/uploads/EXCALIBUR_LINER_F.pdf
ES	https://www.larius.com/wp-content/uploads/EXCALIBUR_LINER_SP.pdf
PL	https://www.larius.com/wp-content/uploads/EXCALIBUR_LINER_PL.pdf

LA4861	EXCALIBUR LINER with 23lt tank
LA4860	EXCALIBUR LINER with 50lt tank



This manual is to be considered as an English language translation of the original manual in Italian. The manufacturer shall bear no responsibility for any damages or inconveniences that may arise due to the incorrect translation of the instructions contained within the original manual in Italian.

Due to a constant product improvement programme, the factory reserves the right to modify technical details mentioned in this manual without prior notice.

EXCALIBUR LINER

Airless line marker with piston pump

INDEX

















A	WARNINGS	P. 4
B	TRANSPORT AND UNPACKING.....	P. 5
C	CONDITIONS OF GUARANTEE	P. 5
D	SAFETY RULES.....	P. 5
E	WORKING PRINCIPLE.....	P. 6
F	TECHNICAL DATA.....	p. 7
G	DESCRIPTION OF THE EQUIPMENT	P.10
H	TUBE CONNECTIONS	P.12
I	STARTING THE MOTOR	P.13
J	WASHING OF THE NEW EQUIPMENT	P.15
K	PRODUCT PREPARATION.....	P.17
L	REGULATIONS.....	P.18
M	WORKING	P.19
N	CLEANING AT THE END WORK	P.20
O	GENERAL MAINTENANCE	P.21
P	ROUTINE MAINTENANCE	P.22
Q	CORRECT PROCEDURE OF DECOMPRESSION	P.24
R	REPLACEMENT OF THE PUMPING GROUP'S GASKETS.....	P.25
S	GLASS BEAD DISPENSER UNIT COMPONENTS - OPTIONAL.....	P.34
T	GLASS BEAD DISPENSER UNIT ASSEMBLY - OPTIONAL	P.35
U	PROBLEMS AND SOLUTIONS	P.41
V	SPARE PARTS	
	COMPLETE PUMPING GROUP REF. LA56562	P.44
W	COMPLETE STEERING UNIT REF. LA4876	P.47
X	FULL FRAME REF. LA4874	P.48
Y	COMPLETE EXCALIBUR LINER UNIT REF. LA4877.....	P.50
Z	COMPLETE 50L TANK REF. LA4895.....	P.52
AA	COMPLETE 20L TANK REF. LA4890.....	P.53
AB	COMPLETE BOX REF. LA4896	P.53
AC	COMPLETE BOX TRASFORMER REF. LA4845	P.55
AD	FLOW COMPENSATOR	P.56
AE	RE-CIRCULATION UNIT COMPLETE WITH COVER RIF. LA4893	P.57
	CE DECLARATION OF CONFORMITY	P.59

**WE ADVISE THE USE OF THIS EQUIPMENT ONLY BY PROFESSIONAL OPERATORS.
 ONLY USE THIS MACHINE FOR USAGE SPECIFICALLY MENTIONED IN THIS MANUAL.**

Thank you for choosing a **SAMOA** product.
 As well as the product purchased, you will receive a range of support services
 enabling you to achieve the results desired, quickly and professionally.

A WARNINGS

The table below provides the meaning of the symbols used in this manual in relation to using, earthing, operating, maintaining, and repairing of this equipment.

	<ul style="list-style-type: none"> • Read this operator's manual carefully before using the equipment. • An improper use of this machine can cause injuries to people or things. • Do not use this machine when under the influence of drugs or alcohol. • Do not modify the equipment under any circumstances. • Use products and solvents that are compatible with the various parts of the equipment, and read the manufacturer's warnings carefully. • See the Technical Details for the equipment given in the Manual. • Check the equipment for worn parts once a day. If any worn parts are found, replace them using ONLY original spare parts. • Keep children and animals away from work area. • Comply with all safety standards.
	<ul style="list-style-type: none"> • It indicates an accident risk or serious damage to equipment if this warning is not followed.
	<p>FIRE AND EXPLOSION HAZARD</p> <ul style="list-style-type: none"> • Solvent and paint fumes in work area can ignite or explode. • To help prevent fire and explosion: <ul style="list-style-type: none"> - Use equipment ONLY in well ventilated area. - Eliminate all ignition sources, such as pilot lights, cigarettes and plastic drop cloths (potential static arc). - Ground equipment and conductive objects. - Use only grounded hoses. - Do not use trichloroethane, methylene chloride, other halogenated hydrocarbon solvents or fluids containing such solvents in pressurized aluminium equipment. Such use can cause serious chemical reaction and equipment rupture, and result in death, serious injury, and property damage. - Do not form connections or switch light switches on or off if the air contains inflammable fumes. • If electrical shocks or discharges are encountered the operation being carried out using the equipment must be stopped immediately. • Keep a fire extinguisher at hand in the immediate vicinity of the work area.
	<ul style="list-style-type: none"> • It indicates wound and finger squashing risk due to movable parts in the equipment. • Tenersi lontano dalle parti in movimento. • Do not use the equipment without the proper protection. • Before any inspection or maintenance of the equipment, carry out the decompression procedure explained in this manual, and prevent any risk of the equipment starting unexpectedly.
 	<ul style="list-style-type: none"> • Report any risk of chemical reaction or explosion if this warning has not been given. • (IF PROVIDED) There is a risk of injury or serious lesion related to contact with the jet from the spray gun. If this should occur, IMMEDIATELY contact a doctor, indicating the type of product injected. • (IF PROVIDED) Do not spray before the guard has been placed over the nozzle and the trigger on the spray gun. • (IF PROVIDED) Do not put your fingers in the spray gun nozzle. • Once work has been completed, before carrying out any maintenance, complete the decompression procedure.
	<ul style="list-style-type: none"> • It indicates important recommendations about disposal and recycling process of products in accordance with the environmental regulations.
     	<ul style="list-style-type: none"> • Mark any clamps attached to earth cables. • Use ONLY 3-wire extension cords and grounded electrical outlets. • Before starting work make sure that the electrical system is grounded and that it complies with safety standards. • High-pressure fluid from gun, hose leaks, or ruptured components will pierce skin. • To help prevent injection, always: <ul style="list-style-type: none"> - (IF PROVIDED) Engage trigger lock when not spraying. - (IF PROVIDED) Do not put your hand over the spray tip. Do not stop or deflect leaks with your hand, body or other. - (IF PROVIDED) Do not point gun at anyone or at any part of the body. - (IF PROVIDED) Never spray without tip guard. - Do pressure relief if you stop spraying or being servicing sprayer and before any maintenance operations. - Do not use components rated less than sprayer Maximum Working Pressure. - Never allow children to use this unit - (IF PROVIDED) Brace yourself; gun may recoil when triggered. • If high pressure fluid pierces your skin, the injury might look like "just a cut", but it is a serious wound! Get immediate medical attention.
   	<ul style="list-style-type: none"> • It is obligatory to wear suitable clothing as gloves, goggles and face shield. • Wear clothing that complies with the safety standards in force in the country in which the equipment is used. • Do not wear bracelets, earrings, rings, chains, or anything else that may hinder the operator's work. • Do not wear clothing with wide sleeves, scarves, ties, or any other piece of clothing that could get tangled up in moving parts of the equipment during the work, inspection, or maintenance cycles.

B TRANSPORT AND UNPACKING

- The packed parts should be handled as indicated in the symbols and markings on the outside of the packing.
- Before installing the equipment, ensure that the area to be used is large enough for such purposes, is properly lit and has a clean, smooth floor surface.
- The manufacturer will not be responsible for the unloading operations and transport to the workplace of the machine.
- Check the packing is undamaged on receipt of the equipment. Unpack the machine and verify if there has been any damage due to transportation.

In case of damage, call immediately the manufacturer and the Shipping Agent. All the notices about possible damage or anomalies must arrive timely within 8 days at least from the date of receipt of the plant through Registered Letter to the Shipping Agent and to the manufacturer.

- The user is responsible for the operations of unloading and handling and should use the maximum care so as not to damage the individual parts or injure anyone. To perform the unloading operation, use only qualified and trained personnel (truck and crane operators, etc.) and also suitable hoisting equipment for the weight of the installation or its parts.

Follow carefully all the safety rules.

The personnel must be equipped with the necessary safety clothing.



The disposal of packaging materials is a customer's competence and must be performed in accordance with the regulations in force in the country where the plant is installed and used. It is nevertheless sound practice to recycle packaging materials in an environment-friendly manner as much as possible.

C CONDITIONS OF GUARANTEE



The conditions of guarantee do not apply in the following situations:

- improper washing and cleaning of components causing malfunction, wear or damage to the equipment or any of its parts;
- improper use of the equipment;
- use that does not conform with applicable national legislation;
- incorrect or faulty installation;
- modifications, interventions and maintenance that have not been authorised by the manufacturer;
- use of non-original spare parts or parts that do not correspond to the specific model;
- total or partial non-compliance with the instructions provided.

D SAFETY RULES

- THE EMPLOYER SHALL TRAIN ITS EMPLOYEES ABOUT ALL THOSE RISKS STEMMING FROM ACCIDENTS, ABOUT THE USE OF SAFETY DEVICES FOR THEIR OWN SAFETY AND ABOUT THE GENERAL RULES FOR ACCIDENT PREVENTION IN COMPLIANCE WITH INTERNATIONAL REGULATIONS AND WITH THE LAWS OF THE COUNTRY WHERE THE PLANT IS USED.
- THE BEHAVIOUR OF THE EMPLOYEES SHALL STRICTLY COMPLY WITH THE ACCIDENT PREVENTION AND ALSO ENVIRONMENTAL REGULATIONS IN FORCE IN THE COUNTRY WHERE THE PLANT IS INSTALLED AND USED.



Read carefully and entirely the following instructions before using the product. Please save these instructions in a safe place.

The unauthorised tampering/replacement of one or more parts composing the machine, the use of accessories, tools, expendable materials other than those recommended by the manufacturer can be a danger of accident.

The manufacturer will be relieved from tort and criminal liability.

- KEEP YOUR WORK PLACE CLEAN AND TIDY. DISORDER WHERE YOU ARE WORKING CREATES A POTENTIAL RISK OF ACCIDENTS.
- ALWAYS KEEP PROPER BALANCE AVOIDING UNUSUAL STANCE.
- BEFORE USING THE TOOL, ENSURE THERE ARE NOT DAMAGED PARTS AND THE MACHINE CAN WORK PROPERLY.
- ALWAYS FOLLOW THE INSTRUCTIONS ABOUT SAFETY AND THE REGULATIONS IN FORCE.
- KEEP THOSE WHO ARE NOT RESPONSIBLE FOR THE EQUIPMENT OUT OF THE WORK AREA.
- **NEVER** EXCEED THE MAXIMUM WORKING PRESSURE INDICATED.
- **NEVER** POINT THE SPRAY GUN AT YOURSELVES OR AT OTHER PEOPLE. THE CONTACT WITH THE CASTING CAN CAUSE SERIOUS INJURIES. IN CASE OF INJURIES CAUSED BY THE GUN CASTING, SEEK IMMEDIATE MEDICAL ADVICE SPECIFYING THE TYPE OF THE PRODUCT INJECTED. **NEVER** UNDERVALUE A WOUND CAUSED BY THE INJECTION OF A FLUID.
- ALWAYS DISCONNECT THE SUPPLY AND RELEASE THE PRESSURE IN THE CIRCUIT BEFORE PERFORMING ANY CHECK OR PART REPLACEMENT OF THE EQUIPMENT.
- NEVER MODIFY ANY PART IN THE EQUIPMENT. CHECK REGULARLY THE COMPONENTS OF THE SYSTEM. REPLACE THE PARTS DAMAGED OR WORN.
- TIGHTEN AND CHECK ALL THE FITTINGS FOR CONNECTION BETWEEN PUMP, FLEXIBLE HOSE AND

SPRAY GUN BEFORE USING THE EQUIPMENT.

- ALWAYS USE THE FLEXIBLE HOSE SUPPLIED WITH STANDARD KIT. THE USE OF ANY ACCESSORIES OR TOOLING OTHER THAN THOSE RECOMMENDED IN THIS MANUAL, MAY CAUSE DAMAGE OR INJURE THE OPERATOR.
- THE FLUID CONTAINED IN THE FLEXIBLE HOSE CAN BE VERY DANGEROUS. HANDLE THE FLEXIBLE HOSE CAREFULLY. DO NOT PULL THE FLEXIBLE HOSE TO MOVE THE EQUIPMENT. NEVER USE A DAMAGED OR A REPAIRED FLEXIBLE HOSE.
- NEVER SPRAY OVER FLAMMABLE PRODUCTS OR SOLVENTS IN CLOSED PLACES.
- NEVER USE THE TOOLING IN PRESENCE OF POTENTIALLY EXPLOSIVE GAS.



The high speed of travel of the product in the hose can create static electricity through discharges and sparks.



It is suggested to earth the equipment. The gun is earthed through the high pressure flexible hose.



All the conductors near the work area must be earthed.



Always check the product is compatible with the materials composing the equipment (*pump, spray gun, flexible hose and accessories*) with which it can come into contact.



Never use paints or solvents containing halogen hydrocarbons (as the methylene chloride). If these products come into contact with aluminium parts can provoke dangerous chemical reactions with risk of corrosion and explosion.



If the product to be used is toxic, avoid inhalation and contact by using protection gloves, goggles and proper face shields.



Take proper safety measures for the protection of hearing in case of work near the plant.

E WORKING PRINCIPLE

The **EXCALIBUR LINER** unit is defined “piston pump”.

An piston pump is used for high pressure painting without air (*from this process derives the term “airless”*).

The internal combustion engine, mounted upon the undercarriage, powers the alternative piston pump.

A cam shaft and a connecting rod allow to obtain the reciprocating motion necessary to the working of the “pumping group” piston. The piston movement produces a “vacuum”.

The product is sucked, pushed towards the pump outlet and then sent to the gun through the flexible hose.

A electronic device, allows to adjust and control the pressure of the material coming out of the pump.

A safety valve avoiding overpressure, guarantees the total reliability of the equipment.

The control zone allows for the possibility of:

- Activating the dispensing spray gun;
- Enabling or disabling the frontal steering wheel;
- Adjust the pressure of work;

This type of equipment is capable of painting one line at a time in a single color.

The line can be either solid or dotted, based on the working requirements.

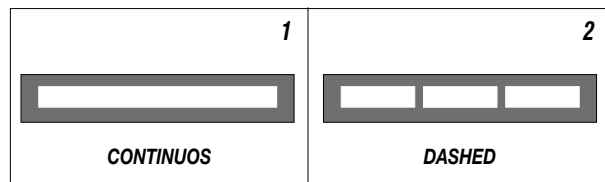

EXCALIBUR LINER is ideal for medium marking and maintenance jobs.



Use water or non-refractive solvent filtered paint specifically designed for airless application.

EXCALIBUR LINER allows for the marking and maintaining of all types lines on highways, freeways, pedestrian crossings, parking lots and squares, as well as every horizontal marking required by the highway code.

Airless marking has numerous proven benefits with respect to line-markers with pressurised tanks, which have been rendered obsolete by airless-technology line markers.

Airless line-marking guarantees:

- Decreased Environmental Impact;
- Decreased drying time.

The paint dries quickly and the line is defined in a uniform manner with a single coat. The airless function requires the use of filtered paint which is specifically designed for airless application. This means that the paint is homogeneous, of a smooth and uniform consistency and will not form crusts, nor will it become gelatinous or thick. With this airless line-marker, the paint adheres firmly to all types of pavement, with optimal visibility, and is resistance to wear caused both by traffic as well as atmospheric agents.

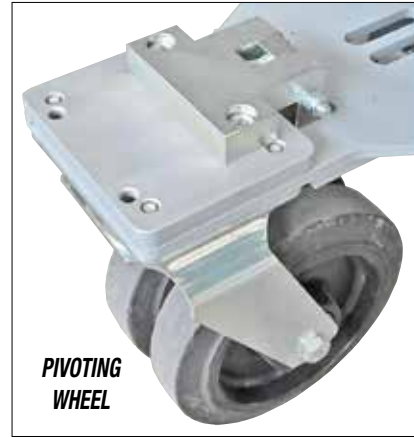

Fig. 2



Fig. 1

With these models, the paint canister can be loaded directly upon the undercarriage or else poured into the non-stick, 50 L tank. In every case, cleaning, maintenance and colour change operations are facilitated.

The line-marker is equipped with pivoting frontal wheel which even increases the agility of the larger models. High yield, high efficiency, high versatility.

This line-marker utilises non-premixed paints. This allows it to achieve about 30 % more yield with respect to standard line-markers. Every model is also an airless spray gun which can be used in the construction/decoration sector together with washable products, enamels, breathable paints and flooring resins. A vast assortment of accessories is available to satisfy every customer demand.

F TECHNICAL DATA

EXCALIBUR LINER	
Max. pressure	220 bar
Max. flow rate	2,2 - l/m
Motor power - Yamaha	4,8 HP
Airless paint capacity	23lt paint can - 50 lt gravity tank
Dimensions	1.400 x 820 x 1.250 mm
Weight	Code LA4861: 108 Kg - Code LA4860: 150Kg

SECTORS OF USE

- External or underground parking lots (schools, hotels, airports, supermarkets, train stations, subway stations, ports);
- External public areas;
- Industrial and exhibition building zones;
- Freeway service areas and service stations;
- Pedestrian median lines, intersections, bicycle tracks, reserved lanes;
- Internal and external logistic area markings;
- Playing fields.



Fig. 1

SFC - TSC SPRAY TIPS/NOZZLES TABLE

Ø nozzle (inch)	Spray angle (°)	Line Width		Flow rate (gpm)	Flow rate (lpm)
		inch	mm		
.013	13 - 20	2 - 4	51 - 102	.18	.69
.015	15 - 20	2 - 4	51 - 102	.24	.91
.017	17 - 20	2 - 4	51 - 102	.31	1.17
	17 - 40	4 - 8	102 - 204		
.019	19 - 20	2 - 4	51 - 102	.38	1.47
	19 - 40	4 - 8	102 - 204		
.021	21 - 40	4 - 8	102 - 204	.47	1.79
	21 - 60	8 - 12	204 - 305		
.023	23 - 40	4 - 8	102 - 204	.57	2.15
	23 - 60	8 - 12	204 - 305		
.025	25 - 40	4 - 8	102 - 204	.67	2.54
	25 - 60	8 - 12	204 - 305		
.027	27 - 40	4 - 8	102 - 204	.77	2.96
	27 - 60	8 - 12	204 - 305		

Ø nozzle (inch)	Spray angle (°)	Line Width		Flow rate (gpm)	Flow rate (lpm)
		inch	mm		
.029	29 - 40	4 - 8	102 - 204	.90	3.42
	29 - 60	8 - 12	204 - 305		
.031	31 - 40	4 - 8	102 - 204	1.03	3.90
	31 - 60	8 - 12	204 - 305		
.035	35 - 40	4 - 8	102 - 204	1.31	4.98
	35 - 60	8 - 12	204 - 305		
.039	39 - 40	4 - 8	102 - 204	1.63	6.18
	39 - 60	8 - 12	204 - 305		
.043	43 - 40	4 - 8	102 - 204	1.98	7.51
	43 - 60	8 - 12	204 - 305		

Code	Manual push	23 lt paint can	50 lt gravity tank	Airless hose	AT250 Airless manual gun	Airless nozzle holder	Super Fast Clean airless nozzles
LA4861	•	•	–	N°1 Code 35015 Ø 1/4"-M16x1,5- 10m	N°1 Code 11210 M16x1,5 inlet swivel	N°1 Code 18270	N°1 SFC 11-40 N°1 SFC 13-40 N°1 N°1 SFC 15-40
LA4860	•	–	•	N°1 Code 35015 Ø 1/4"-M16x1,5- 10m	N°1 Code 11210 M16x1,5 inlet swivel	N°1 Code 18270	N°1 SFC 11-40 N°1 SFC 13-40 N°1 N°1 SFC 15-40

CONFIGURATIONS		
CODE	LA4861	LA4860
Petrol engine power	4,8 HP	4,8 HP
Max. Flow rate	2,2 l/m	2,2 l/m
Max. Pressure	220 bar	220 bar
Manual push	•	•
Self propelled	–	–
Head control system	–	–
Automatic marking lines kit	–	–
Glass beads kit	–	–
Flashing telescopic rod kit	–	–
Working light kit	–	–
Operator footboard kit	–	–
Piston type accumulator	–	–
23 L Paint can	•	–
50 L Gravity tank	–	•

CONFIGURATIONS		
CODE	LA4861	LA4860
Airless hose Ø 1/4" - M16 x 1,5 - 10M	•	•
Airless hose Ø 1/4" - M16 x 1,5 - 15M	–	–
Recirculation Hose	•	•
Filter with pressure gauge	•	•
1 AT250 Airless manual spray gun	•	•
2 AT250 Airless manual spray guns	–	–
2 LA96 Airless manual spray guns	–	–
Airless nozzle holder	•	•
Super fast clean airless spraying nozzles	•	•
1 colour	•	•
1 single line: continuous - dashed	•	•
2 double line: continuous - dashed -mixed	–	–
Tools kit	•	•

ACCESSORIES	
Code	Description
LA35015	Airless hose Ø 1/4" - M16 x 1,5 - 10 m
LA11200	AT250 manual airless spray gun - M16x1,5 inlet swivel+ Nozzle holder
LA11210	AT250 manual airless spray gun - M16x1,5 inlet swivel
LA18270	Airless nozzle holder
LASFC	Super Fast Clean airless nozzle. Size from 11-20 to 51-80
LATSC	Super Fast Clean airless nozzle. Size from 7-20 to 31-60
LA18240	50 l Gravity tank
LA18245	50 l Gravity tank + Cover
LA18241	50 l Gravity tank + Cover + Basket
LA4500	11 l Gravity tank + Glass beads diffuser hose

ACCESSORIES	
Code	Description
LA200270	Complete kit for second airless gun for Part No. LA4861 and Part No. LA4860 (mounting kit Part No. LA4307/1 + airless gun Part No. LA 1100 + airless nozzles Part No. LASFC 11 - 40/13 - 40/15 - 40).
LA4307/1	Mounting kit for second airless gun (airless gun not included)
LA18359	11 l Gravity tank + 1 Diffuser hose + 1 Glass beads manual spray gun kit
LA18359/2	11 l Gravity tank + 1 Diffuser hose + 2 Glass beads manual spray guns kit
LA4038	Laser pointer kit
LA4840	Gun handling + Front pivot wheel kit (manual push airless line strippers models)

G DESCRIPTION OF THE EQUIPMENT

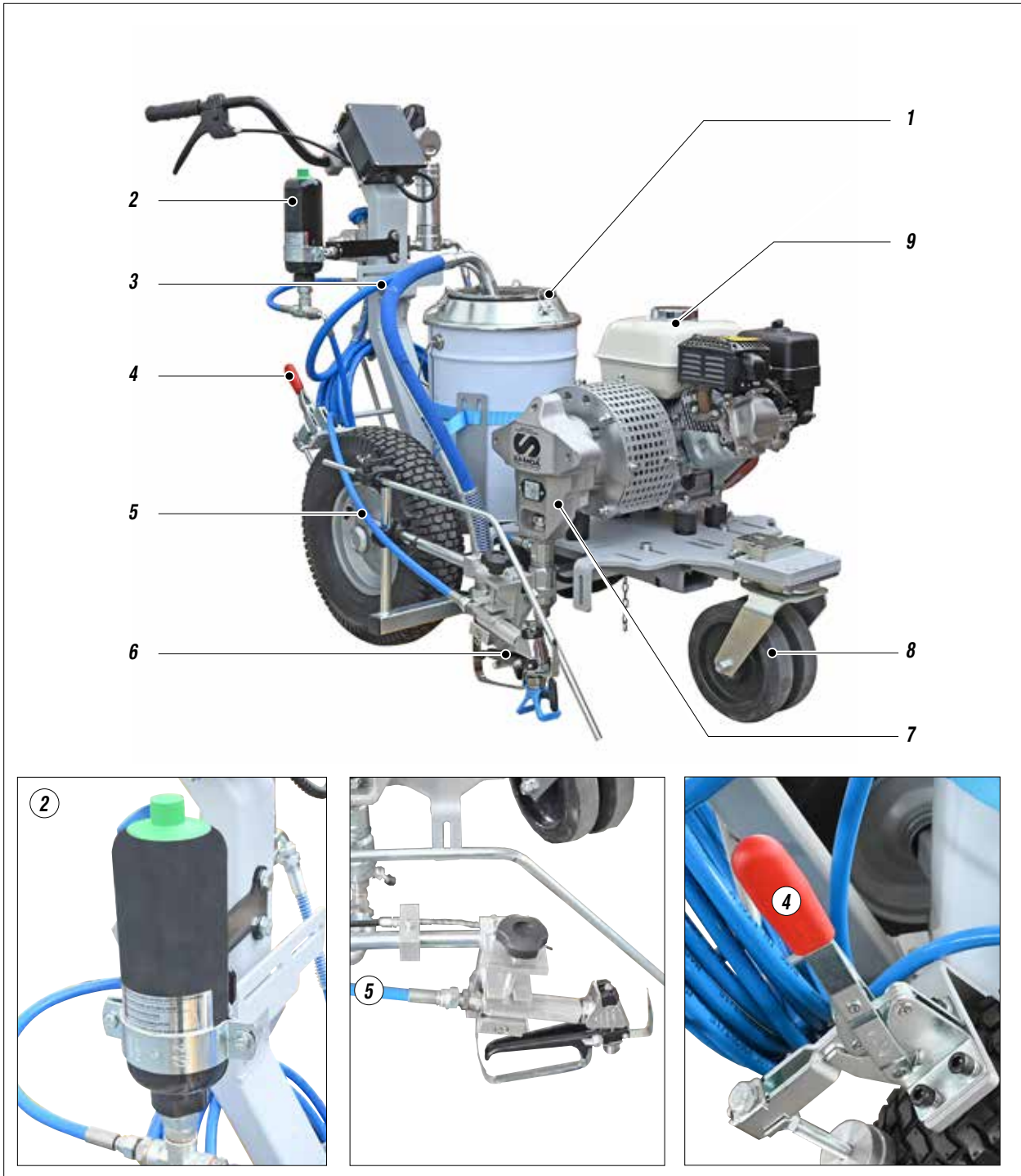

Fig. 1

Pos.	Description
1	lt. 20 tank
2	Flow compensator
3	Product suction pipe
4	Brake
5	Product supply tube

Pos.	Description
6	Gun AT250
7	Pumping group
8	Pivoting wheel
9	Gasoline tank

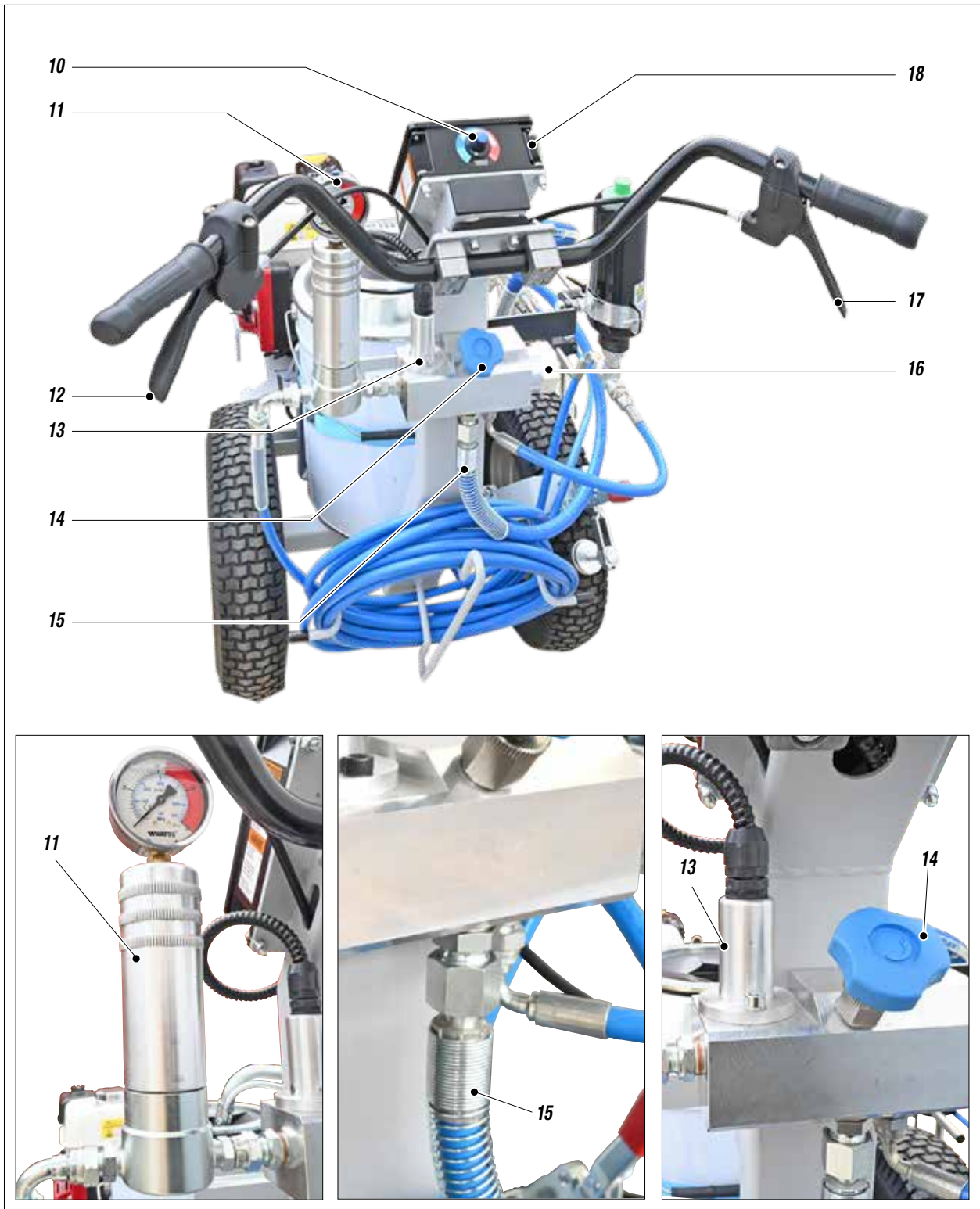

Fig. 2

Pos.	Description
10	Potentiometer for adjusting the operating pressure
11	Manometer
12	Directional wheel lock/release lever
13	Pressure gauge
14	Safety-recirculation valve

Pos.	Description
15	Product recirculation tube
16	Plug
17	Gun operating lever
18	ON/OFF switch

H TUBE CONNECTIONS

Flexible re-circulation tube connection

- Connect the flexible re-circulation tube (1) to the connector (2) ensuring to tighten the fittings (*the use of two wrenches is suggested*).

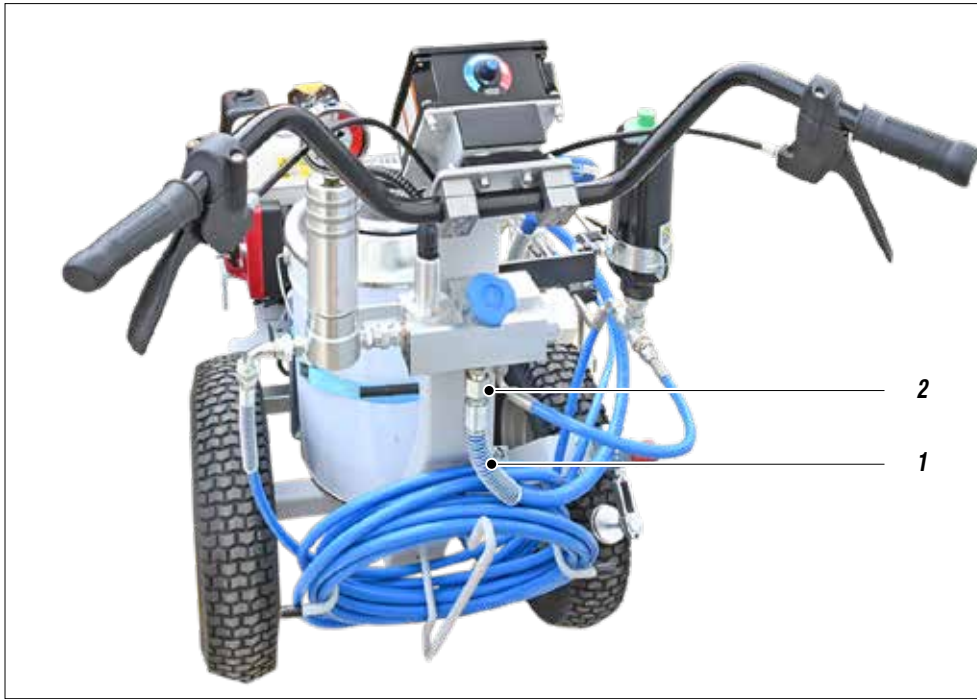

Fig. 1

Pump unit flexible tube connection

- Connect the pump unit's flexible tube (H) to the connector (4) ensuring to tighten the fittings (*the use of two wrenches is suggested*).



Fig. 2



Fig. 3

Hose connection to the flow compensator

- Connect the hose (5) between the flow compensator (6) to the recirculation group (7) (*the use of two wrenches is suggested*).

Flexible tube and spray gun connection

- Connect the flexible tube (8) to the connector (9) ensuring to tighten the fittings (*the use of two wrenches is suggested*).

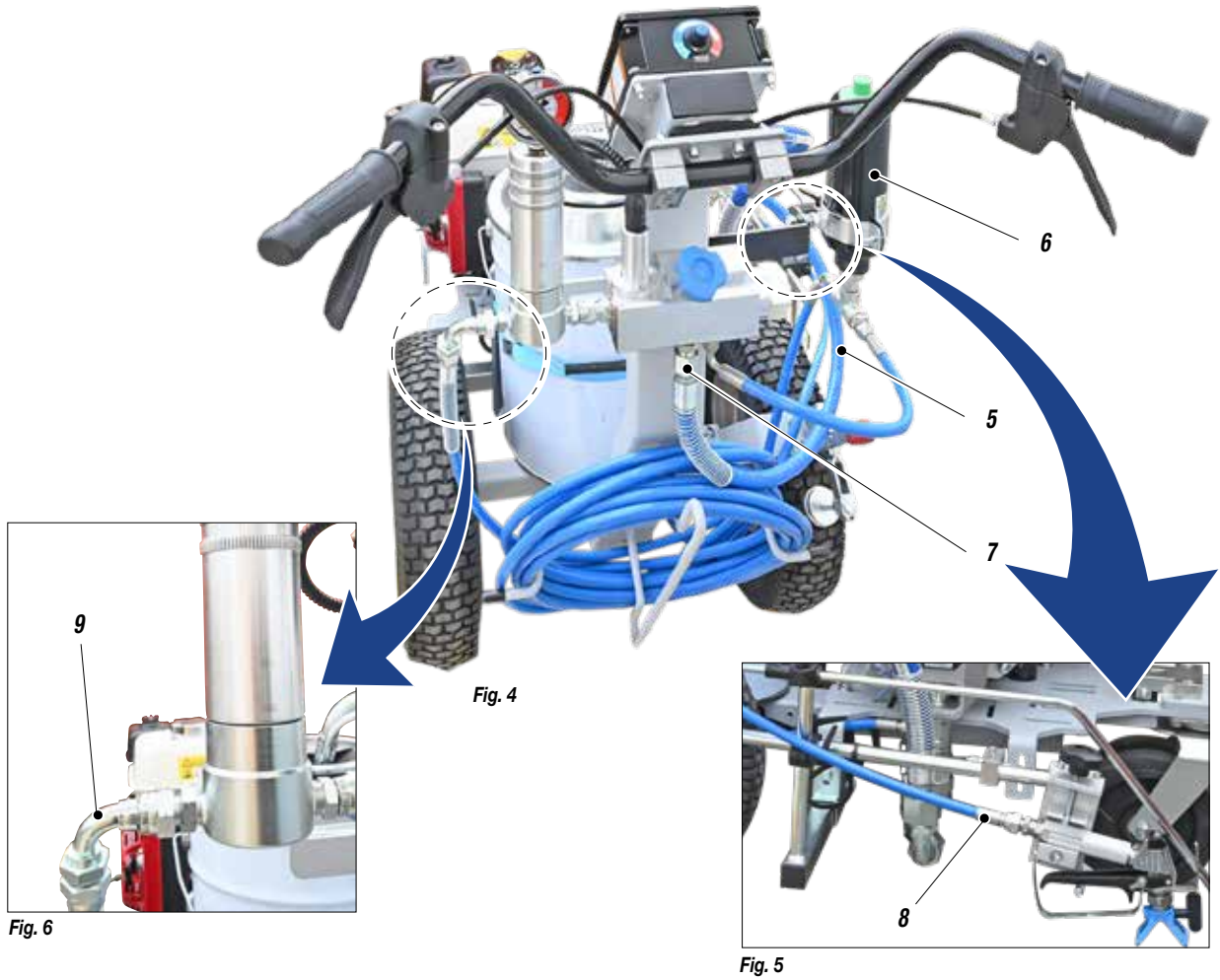

- It is recommended to use the hose provided with the standard kit (ref. LA18036).
NEVER use a damaged or a repaired flexible hose.
NEVER use sealants on fittings' threads.

I STARTING THE MOTOR

In order to start the motor, proceed as follows:

- 1** Fill the gasoline tank (1).



Fig. 1

2

Open the fuel valve (2) and position it to "ON".



Fig. 2

3

Put the air lever (3) on CLOSE.



Fig. 3

4

Bring the accelerator lever (4) to about 1/2 of its run.



Fig. 4

5**PULL-START**

5.1 Turn the key selector (5a) to the ON position.

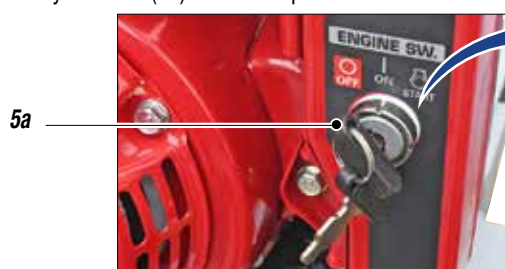

Fig. 5

5.2 Pull the start up cord (5b).

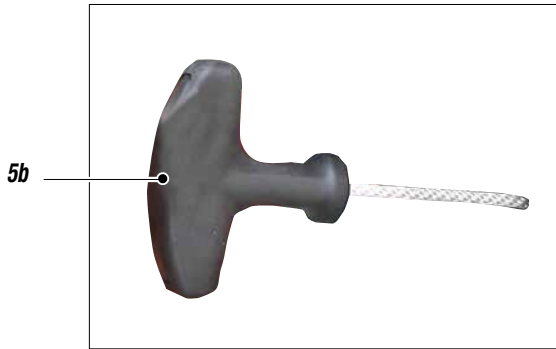

Fig. 6

ELECTRIC STARTER MOTOR

Turn the ignition key selector (5c) to **START** and hold it in position until the engine starts.

Once the engine starts, return the selector to **ON**.

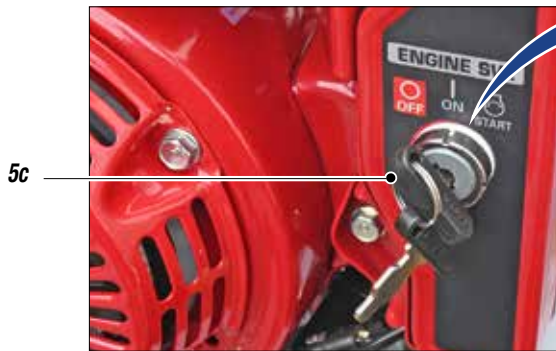

Fig. 7

J WASHING OF THE NEW EQUIPMENT

- The equipment has already been adjusted at our factory with light mineral oil left inside the pumping group as protection. Therefore, wash with diluent before sucking the product.
- Lift the suction pipe and dip it into the solvent tank.
- Clean the inside of the tank with a brush.
- Ensure the gun (1) is without nozzle.
- Start the motor following the indications provided in the chapter **"STARTING THE MOTOR"**.
- Press the switch (2) of the equipment **"ON"** (I).

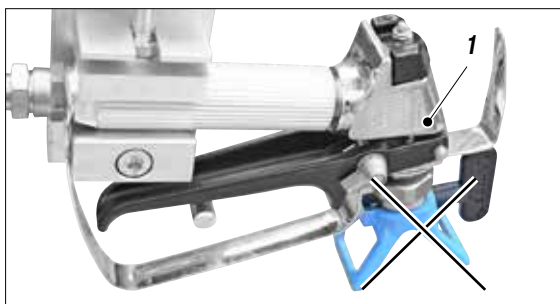

Fig. 1



Fig. 2

2

- Open the recirculating-safety valve (3).

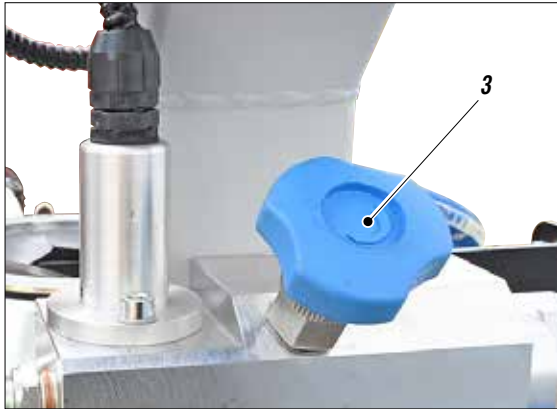

Fig. 3

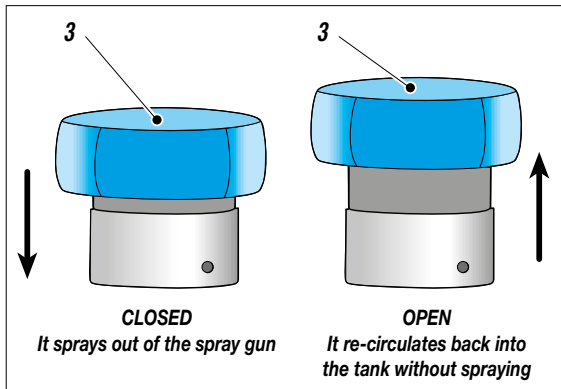

Fig. 4

- Turn the pressure setting knob (4) clockwise to the "CIRCULATION & WASHING" position (drop symbol).

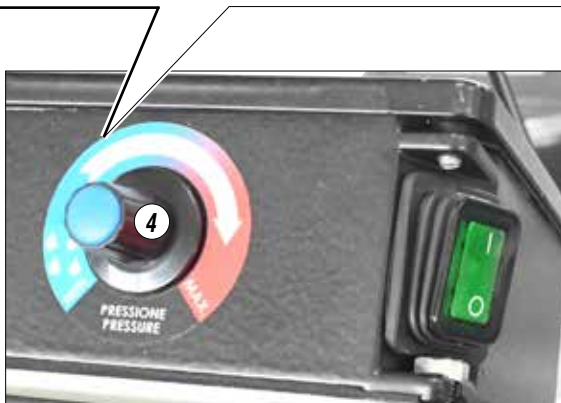
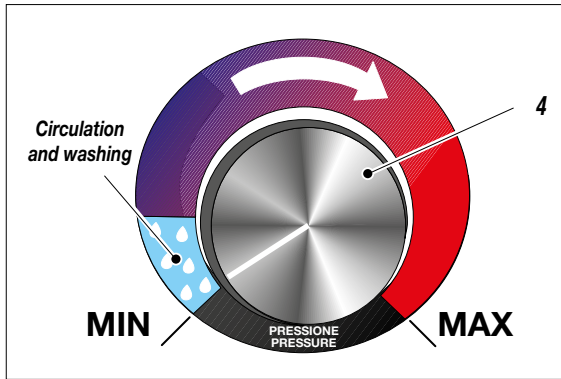

Fig. 5

- Visually check that the wash fluid starts to re-circulate within the tank (5).

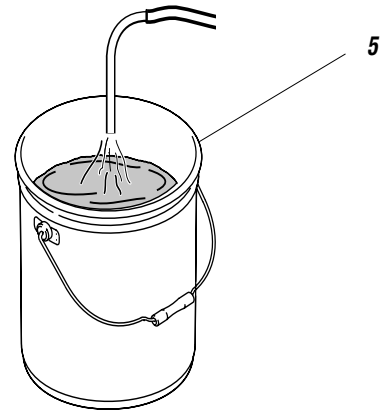

Fig. 6

- Turn pressure regulating knob (4) clockwise a little so that the machine idles.

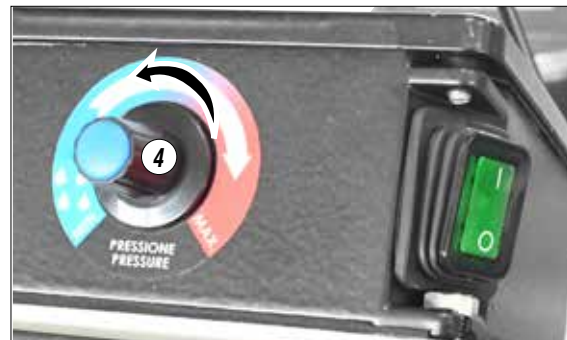

Fig. 7

- Turn the pressure adjustment handle (4) clockwise to stop the pump.
- Closed the recirculating-safety valve (3).

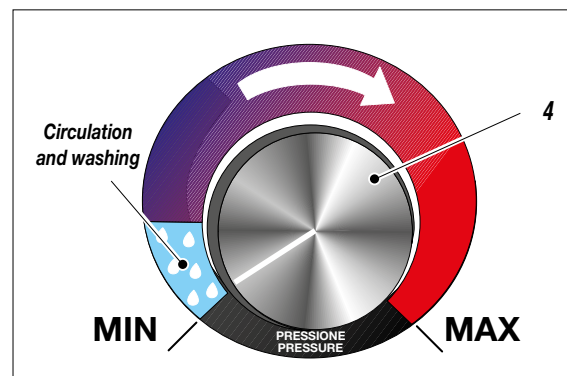

Fig. 8

- Remove the gun (6) from its support and point it into a container (7). Hold the trigger down (to perform the cleaning) until clean solvent comes out, or else until all of the wash fluid has been expelled from the tank.

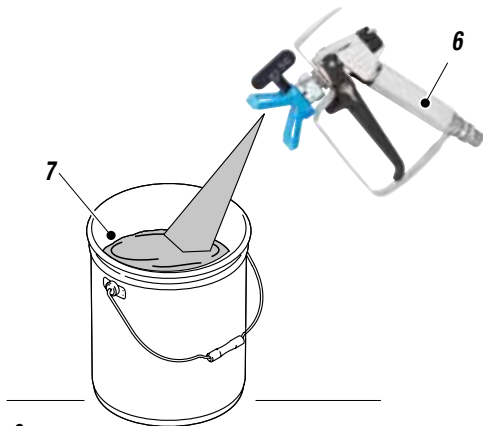

Fig. 9



Repeat the same operations with clean solvent if necessary.

- After having completed the wash operations, bring the handle to its MIN position (4) and point the gun (6) into a collection container (7) and press the trigger to release the residual pressure. Release the trigger when finished.

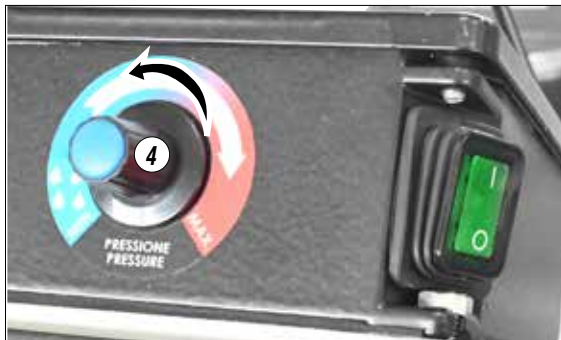

Fig. 10

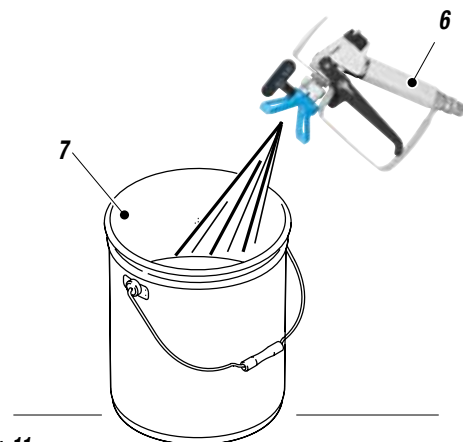

Fig. 11



Absolutely avoid to spray solvents indoors. In addition, it is recommended to keep away from the pump in order to avoid the contact between the solvent fumes and the motor.

- Shut off the equipment by turning the switch to its **OFF** position "(O)".
- Stop the combustion engine.
- At this point the machine is ready. If water-based paints are to be used, after the wash with solvent wash the tank again with soap and water, then rinse with clean water (repeating the previously described procedures).
- Insert the manual gun trigger lock and assemble the nozzle.

K PRODUCT PREPARATION



MAKE SURE THE PRODUCT IS SUITABLE TO BE USED WITH A SPRAY GUN.

- Mix and filter the product before using it. For filtration use **CLOSE-MESH** (ref. LA214) and **LARGE-MESH** (ref. LA215) LARIUS METEX braids.



Make sure the product to be used is compatible with the materials employed for manufacturing the equipment (stainless steel and aluminium). Because of that, please contact the supplier of the product.

Never use products containing halogen hydrocarbons (as *methylene chloride*). If these products come into contact with aluminium parts of the equipment, can provoke dangerous chemical reactions with risk of explosion.

- Fill the tank (1) with the paint.

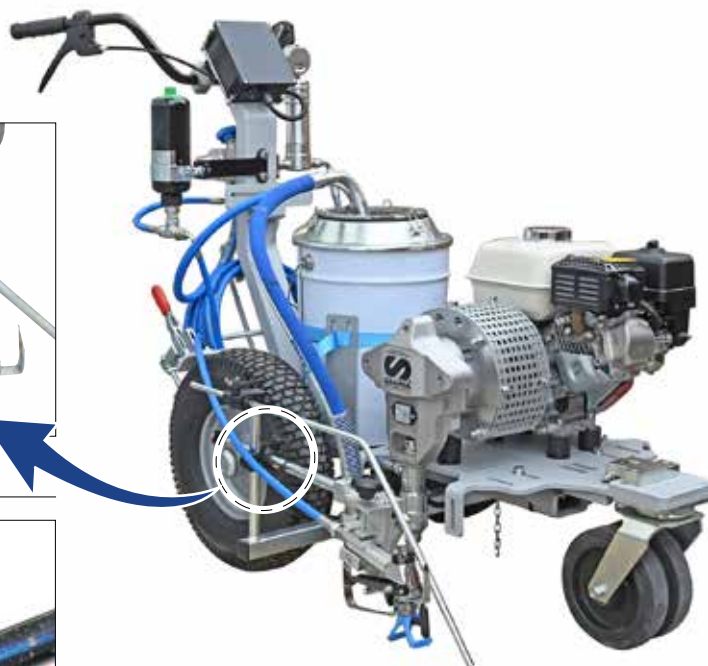
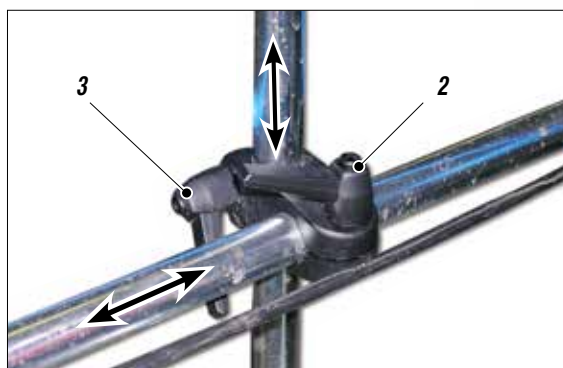
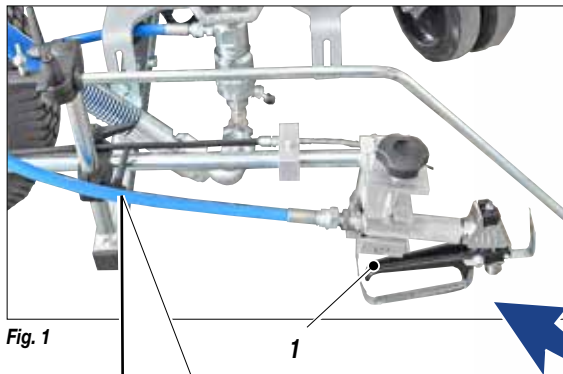

Fig. 1

L REGULATIONS

ADJUSTING THE SPRAY GUN

In order to adjust the position of the spray gun (1) use the knobs (2-3).



ADJUSTING THE GUIDE ROD

In order to adjust the position of the guide rod (4) use the knobs (5-6).

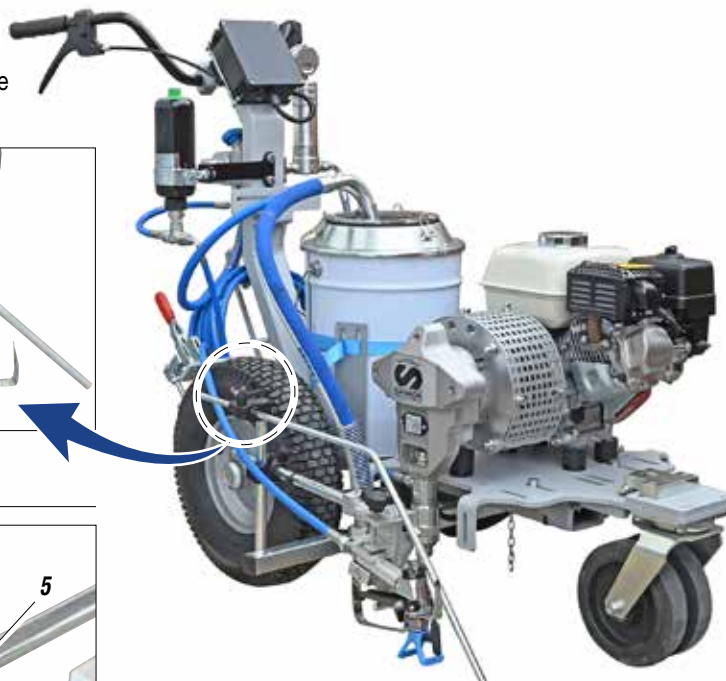
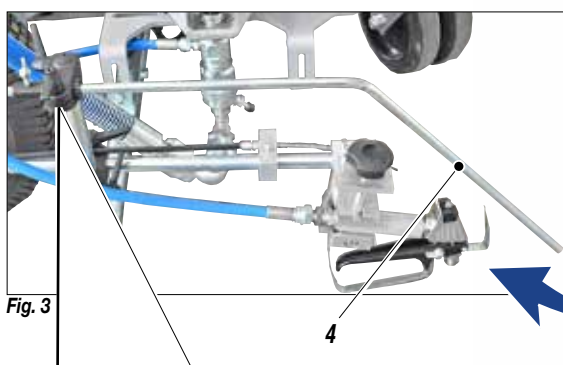

M WORKING



During the first start-up of the **EXCALIBUR LINER PLUS** operate at low speed without accelerating too much. This allows the machine, vibrating less, to prime faster and to suck up the product faster.

SETUP PROCEDURE

- Use the tooling after performing all the **SETTING UP** operations above described.

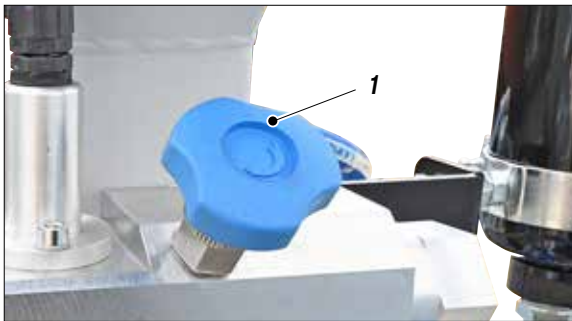

Fig. 1

- Check that there is enough unleaded petrol.
- Start the motor following the indications provided in the chapter "**STARTING THE MOTOR**".
- Make sure that the re-circulation/safety valve (1) is closed (*spray enabled*).
- Press the switch (2) of the equipment "**ON**" (I).
- Turn the pressure adjustment handle clockwise until the desired setting has been reached.



Fig. 2

ADJUSTING PUMP UNIT SPEED

- Move the motor acceleration lever (3) gently to increase or decrease the speed of the pump.

During the painting operation it is normally recommended to maintain the position of the accelerator lever (3) at about 3/4 of its maximum run.



Fig. 3

SPRAY ADJUSTMENT

- Slowly turn clockwise the pressure control knob to reach the pressure value in order to ensure a good atomization of the product.
- An irregular and marked spray on the sides indicates a low working pressure. On the contrary, a too high pressure causes a high fog ("*overspray*") and waste of product.
- Pull the lever on the right (M4) to activate the spray gun and begin working, advancing the machine in a continuous manner.



Fig. 4



NEVER point the spray gun at yourselves or at other people. The contact with the casting can cause serious injuries. In case of injuries caused by the gun casting, seek immediate medical advice specifying the type of the product injected.



Recirculating-safety valve: when working at the maximum pressure available, releasing the gun trigger sudden increases of pressure can occur. In this case, the recirculating-safety valve opens automatically eliminating part of the product from the recirculating tube. Then it closes so as to go back to the first working conditions.

N CLEANING AT THE END WORK



Fig. 1

- Release the residual pressure by holding down the trigger of the gun (2) and pointing it into a container (3).

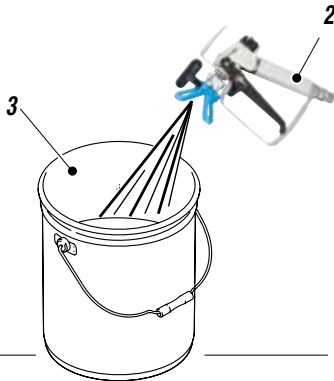

Fig. 2

- Eliminate the paint remaining within the tank (4) by placing the re-circulation tube (5) into a container.
- Open the recirculating-safety valve (6).

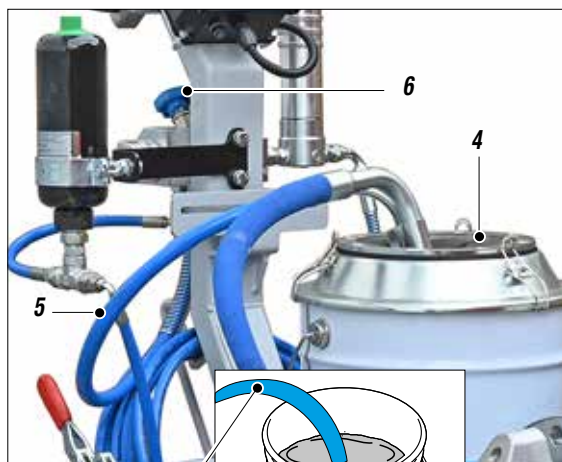
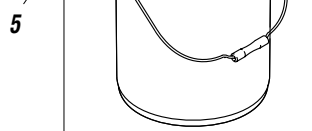

Fig. 3



- Turn the pressure adjustment (1) handle slightly clockwise to make the machine function at minimum pressure (*pump activated*), until the tank has been completely emptied then shut off the pump by bringing the handle (1) to its minimum position.
- Fill the tank (4) with wash fluid.

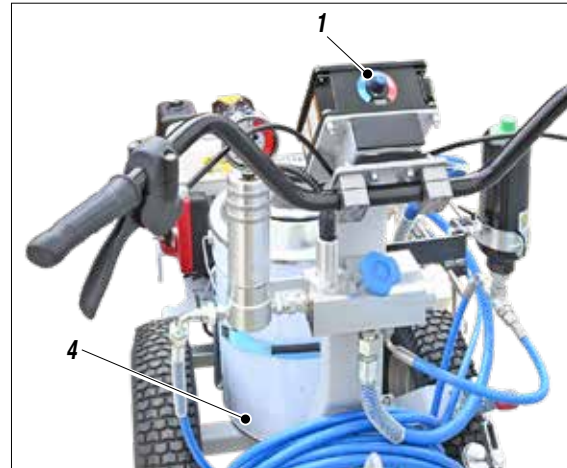

Fig. 4

- Clean the walls of the tank with a brush.
- Turn the pressure adjustment (1) handle slightly clockwise to make the machine function at minimum pressure (*pump activated*).



Fig. 5

- Make sure the re-circulation tube (5) is inserted into a container and wait for clean wash fluid to come out of it.
- Turn the pressure adjustment handle (1) to minimum (*pump stopped*).
- Place the re-circulation tube back into the tank.
- Keep the gun's trigger pressed to release any residual pressure.
- Remove the nozzle from the gun and wash it separately.
- Closed the recirculating-safety valve
- Turn the pressure adjustment handle (1) slightly clockwise to make the machine function at minimum pressure (*pump activated*).

- Point the manual gun (7) into a container (8), drain the residual paint and wait for the wash fluid to come out clean the entire spraying circuit.

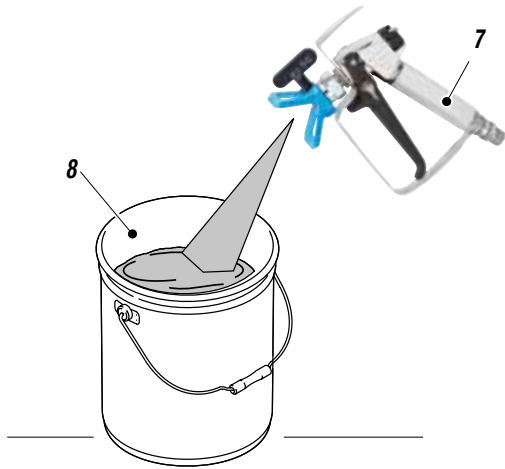

Fig. 6



Fig. 7

- In case of long storage, we recommend you to suck and to leave light mineral oil inside the pumping group and the flexible hose.

- Empty all of the wash fluid from the tank and turn off the equipment.
- Turn the pressure adjustment handle (N1) to minimum (*pump stopped*).
- Shut off the motor.



Follow the washing procedure before using again the equipment.

0 GENERAL MAINTENANCE



Discharge the pressure in the pump unit (*open the discharge valve*) before carrying out any maintenance.

DAILY

- Clean the filters;
- Clean the nozzles;
- Clean all the varnish circuit with a specific product;
- Check the fuel motor (*see the maintenance table*).

PERIODICALLY

- Check the pumping gaskets draft (*if the product draws, replace gaskets*);
- Clean the mobile parts from the varnish deposits (*spray guns, etc.*);
- Check the gun cables tightening, the wheel block;
- Check that the tubes and all the fittings are correctly locked.

P ROUTINE MAINTENANCE



Always check that there is oil in the motor.

Check the motor oil every 100 working hours via the relevant measuring caps positioned on the bottom of the petrol motor. Top up if necessary.

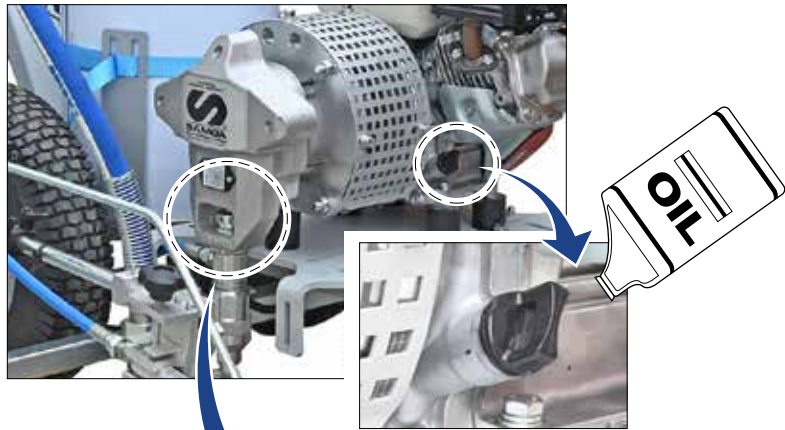

Fig. 1

CHECK ON THE PACKING NUT

Daily check the packing nut is tight in order to avoid wastes but **not excessively** to prevent the piston from seizing and the gaskets from wearing.

- Use the lubricant (1) supplied (ref. LA16340) to allow an easy sliding of the piston inside the gasket group. **Daily top up the packing nut.**

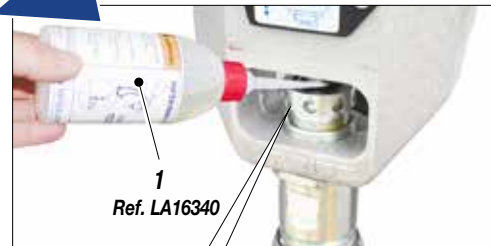

Fig. 2



At the start of each working day check that the ring nut is full of hydraulic oil (Ref. LA16340). This oil makes it easier for the piston to slide and prevents any material that escapes via the seal gasket drying when the equipment is stopped.

- For tightening, use the wrench supplied (ref. LA11503).



Check the packing nut is tight in order to avoid wastes but **not excessively** to prevent the piston from seizing and the gaskets from wearing.



Ref. LA11503
Closing/opening pin

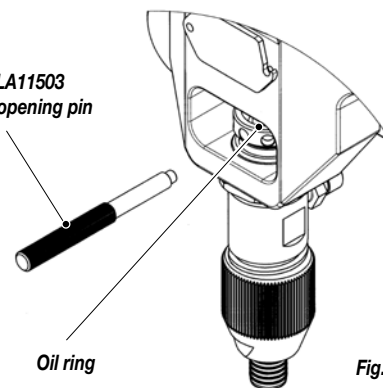

Fig. 3

MOTOR FILTER CLEANING AND REPLACEMENT

Periodically provide for the cleaning and, if necessary, replacement of the motor filter following the procedure outlined below

1

Unscrew the screw (1) securing the filter coover (2).

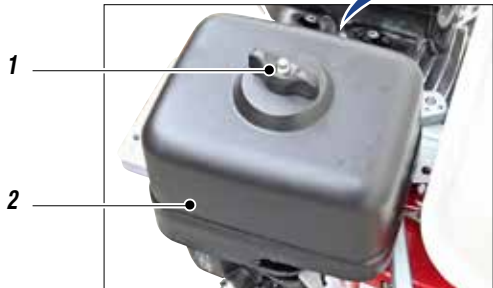

Fig. 1

2

Remove the filter cover (3).



Fig. 2

3

Unscrew the screw securing the filter (4) and remove it.



Fig. 3

4

Remove the filter (5), clean it, and, if necessary, replace it. Follow the reverse procedure to reassemble the filter.



Fig. 4

Q CORRECT PROCEDURE OF DECOMPRESSION

- Move the switch (1) to the **OFF (0)** position to stop the equipment.
- Point the gun (4) at the receptacle (5) used to collect the product and press the trigger to release the pressure. When completed, activate the safety catch again.



Fig. 1

1

- Reduce pressure to the minimum (turn counterclockwise the pressure control knob (2)).

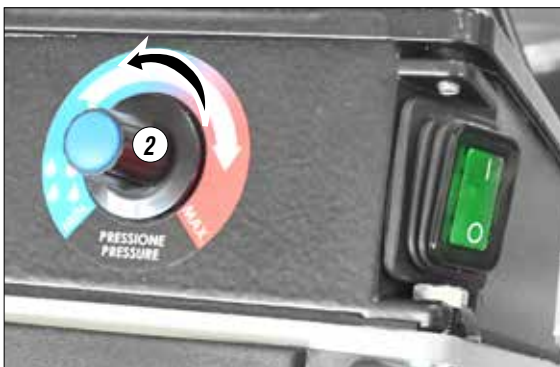

Fig. 2

- Unlock the safety clamp (3).

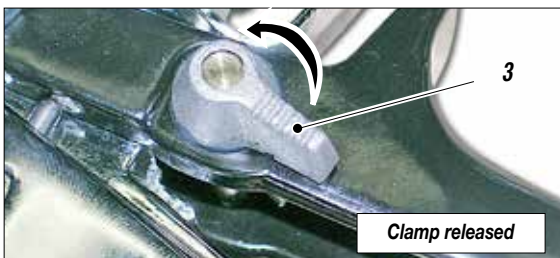

Fig. 3

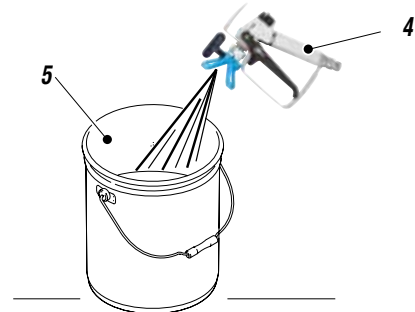

Fig. 4

- Open the recirculating-safety valve (6) to release the remaining pressure.



Fig. 5

WARNING:

If the equipment is still under pressure after performing the operations above described because of the nozzle or the flexible hose clogged, proceed as follows:



- Loosen very slowly the gun nozzle.
- Release the clamp.
- Point the gun at the container of the product and press the trigger to release pressure.
- Loosen very slowly the fitting of connection from the flexible hose to the gun.
- Clean or replace the flexible hose and the nozzle.

R REPLACEMENT OF THE PUMPING GROUP'S GASKETS

Each time you use the machine, check for material leaking from the top of the ring nut.
If any material leaks out when the pump is working at the set pressure, proceed as follows:

- Carry out this operation after cleaning the tooling.



Always disconnect the power supply and release pressure before going on with the operations (follow the "correct procedure of decompression"). The gaskets are self-adjusting. If a leak occurs they must be replaced.

- Use a 19 mm spanner to unscrew the ring nut (1) on the feed pipe in order to make the operation easier.

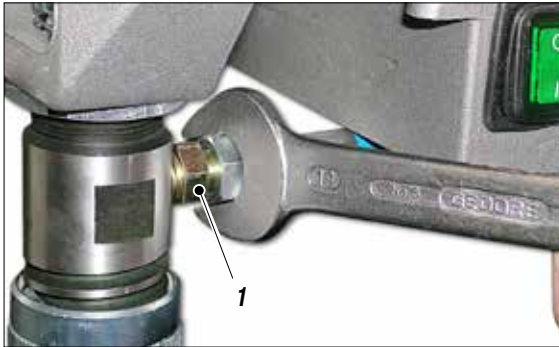

Fig. 1

- Release the plastic covering (2).

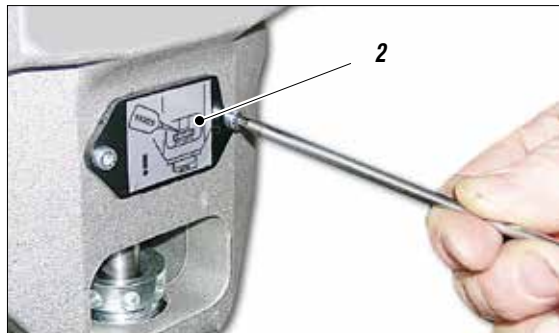

Fig. 2

- Pull the ignition belt (3) lightly until the piston rod has been brought to the lowest point of its stroke.



Fig. 3

- Remove the locking pin (4) using pliers (5).



Fig. 4

- Unscrew the fixing ring nut (6) to the end of the thread using a 45 mm spanner.



Fig. 5

- Unscrew the suction casing using a 32 mm spanner as illustrated. If necessary, remove the suction pipe (7) before continuing with the other operations.

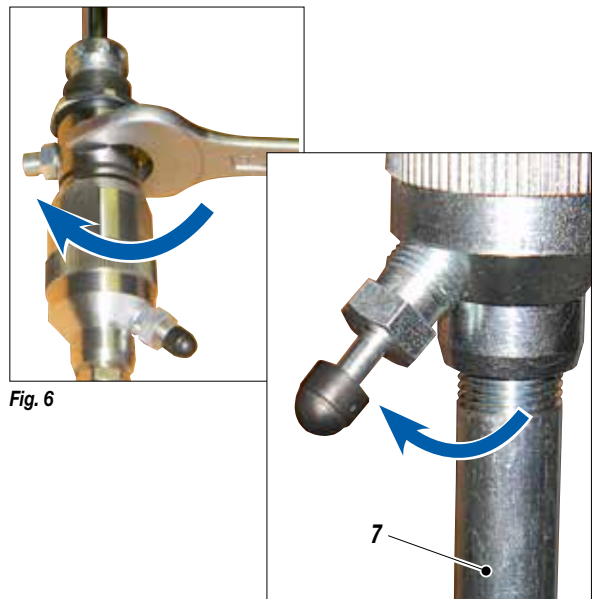

Fig. 6

- Disconnect the pumping group by unscrewing the fastening nut (*wrench 45*).
- Unscrew the pumping group from the housing.

You can now work easily as the pump casing has been freed.

- Grip the complete pump unit (9) in a vice (8) (as shown).

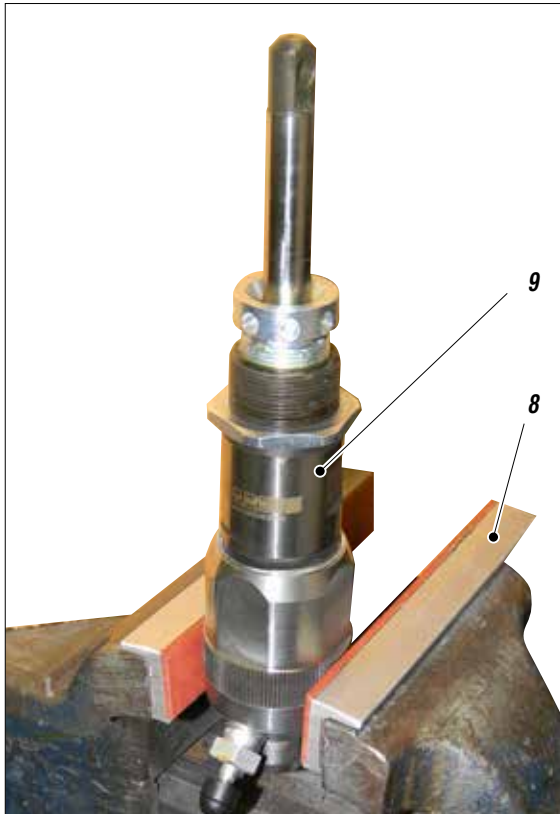

Fig. 7

- Allentare la ghiera (10) di due giri completi con l'apposito perno (11) in dotazione. Ruotare in senso antiorario come illustrato.

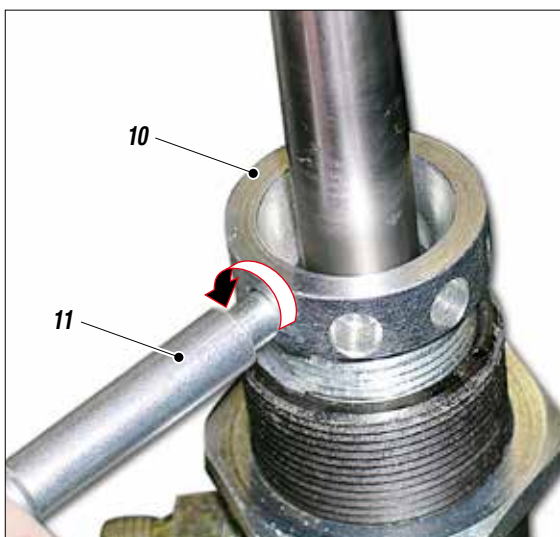

Fig. 5

- Use a 36 mm spanner to unscrew the pump unit as shown.



Fig. 5

- Remove the pump unit (12) from the foot valve (13) as shown. **Inspect the two parts separately.**

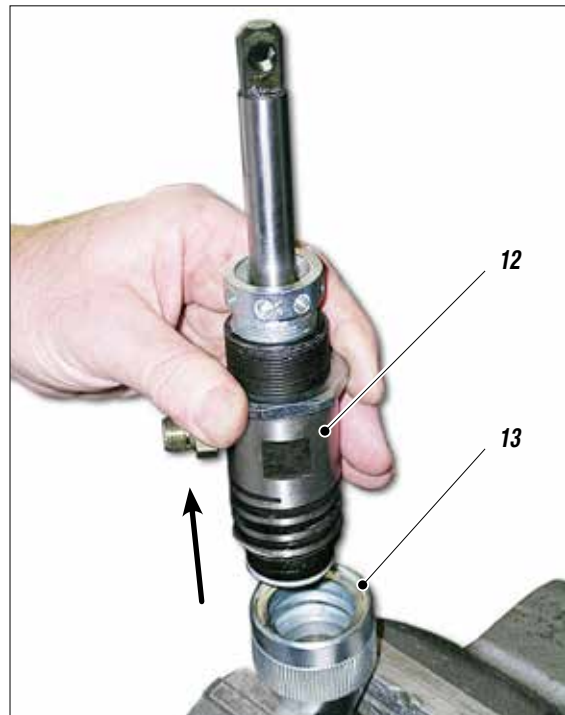

Fig. 7

PIT STOP MAINTENANCE

Replacement of upper and lower gaskets 25 minutes.

REPLACING THE FOOT VALVE SEALS

- Replace the PTFE gasket (14) located under the ball seating (15).
- Check that the surfaces of the ball seating (15) and the ball (16) are not damaged. If necessary, replace both of them.
- Fit them again using the component sequence shown.

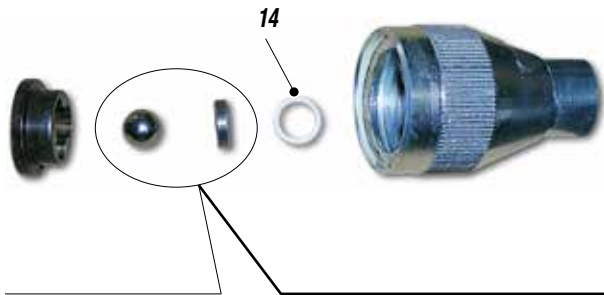
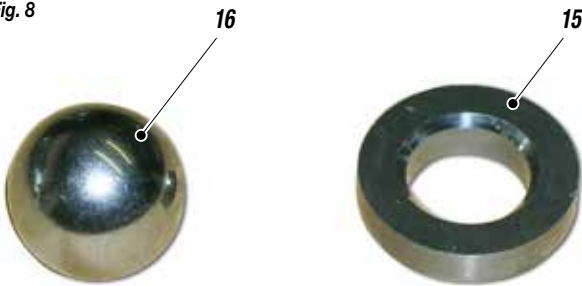

Fig. 8



- Unscrew the gasket compression ring nut (19) completely. **All the gaskets in the unit must be replaced at the same time to allow the machine to work properly.**

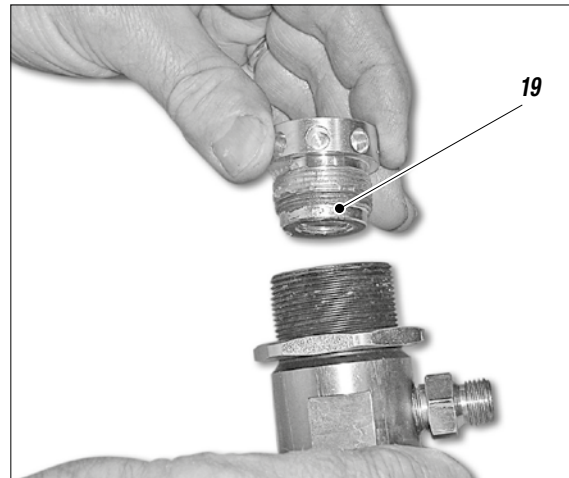

Fig. 10

- Remove the upper stainless steel female ring (20) as shown

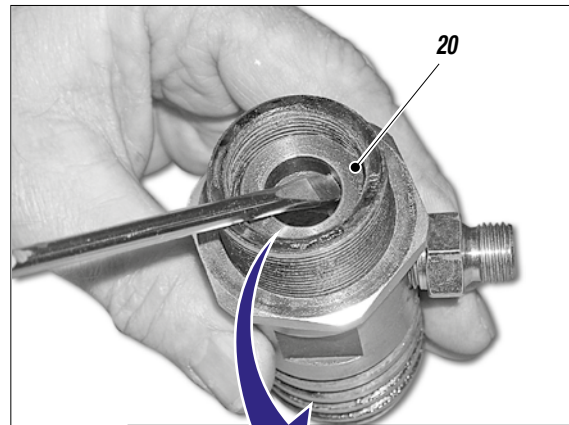

Fig. 11



REPLACING THE PUMP UNIT HOUSING UPPER GASKET

- Remove the piston stem (17) from the pump unit housing (18) as shown.



Fig. 9

- Remove the series of gaskets contained inside the pump unit housing, as shown.



Fig. 11

U P P E R

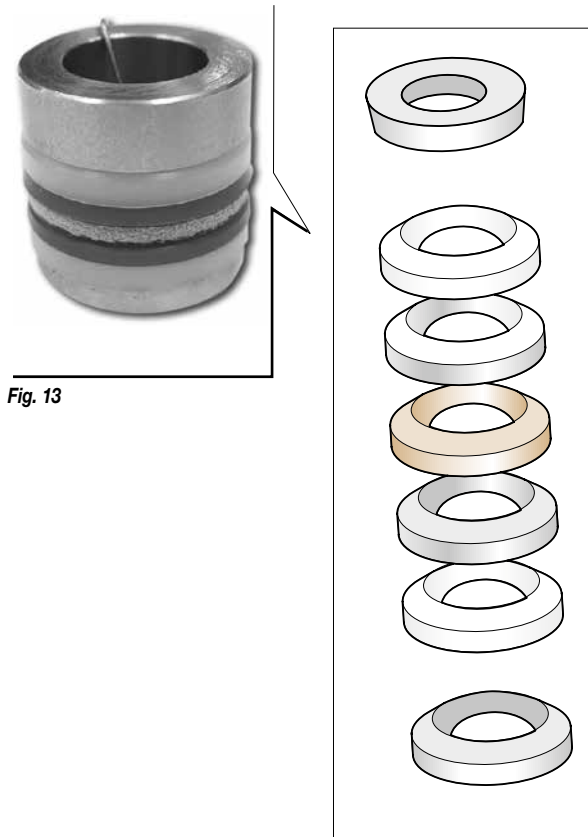
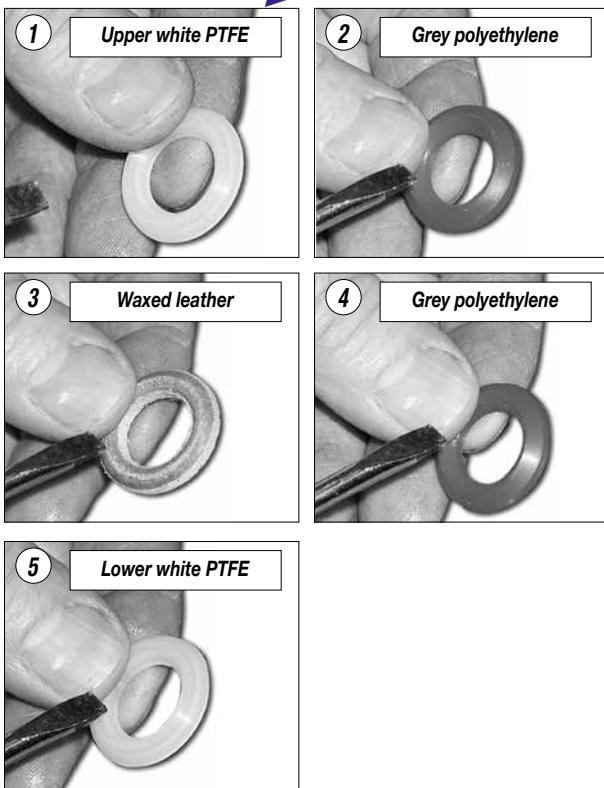

Fig. 13



- Remove the lower stainless steel male ring (21) as shown.



Fig. 12

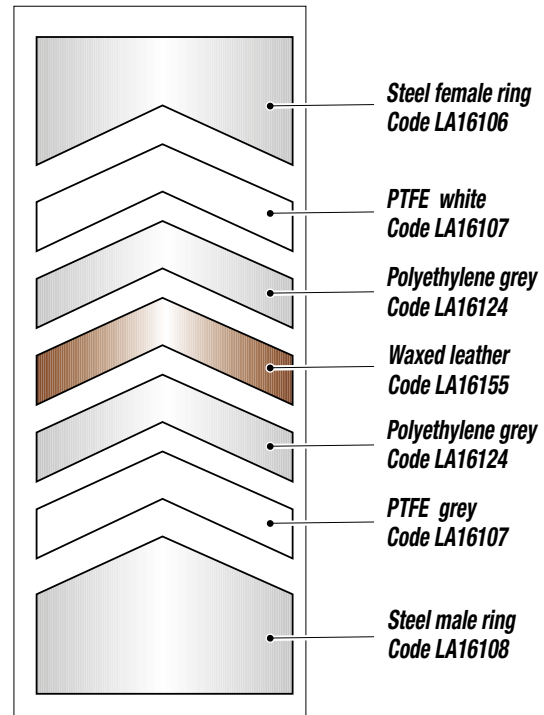

Fig. 14

- Fit the new gasket kit according to the component sequence shown in the figure.

- Remove the PTFE O-ring (22) and replace it with a new one (23).

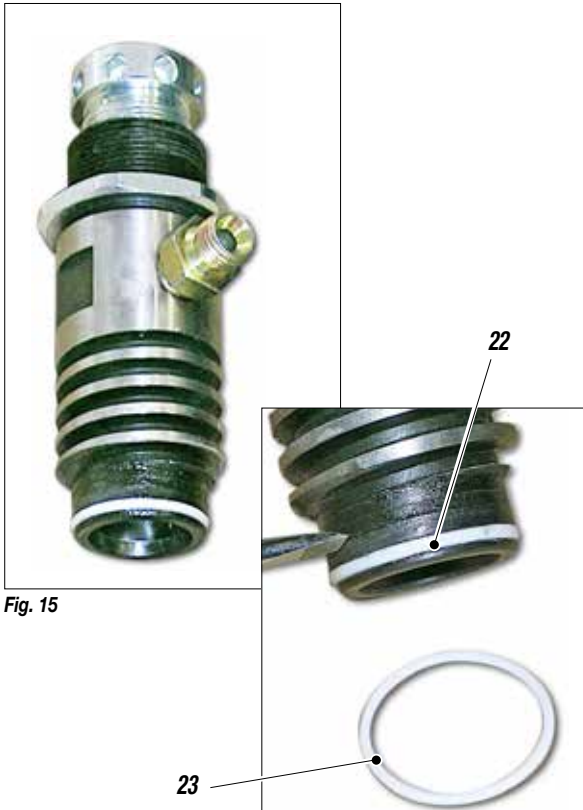

Fig. 15

REPLACING THE PUMP UNIT STEM GASKET

- Secure the stem (18) in a vice as shown.

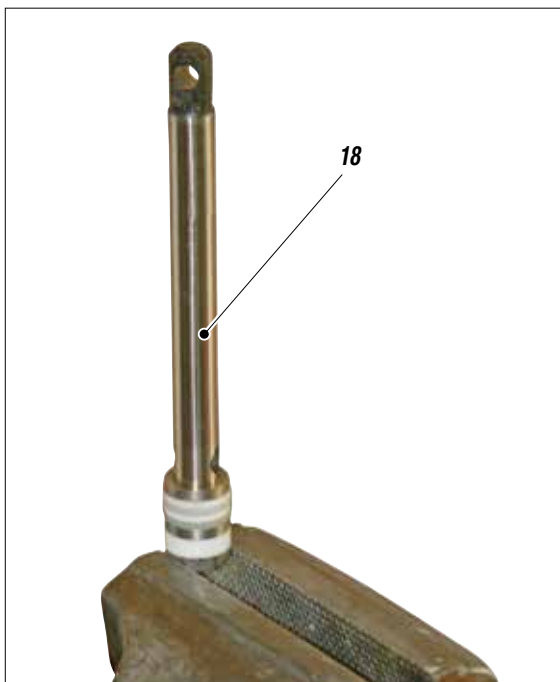

Fig. 16

- Use a 10 mm spanner to unscrew and remove the stem (19) as indicated.
- Remove the complete gasket kit (24) from the stem (18), as shown, in order to replace it.

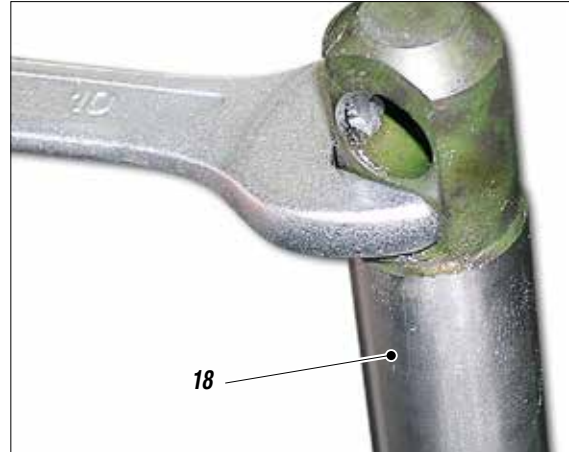

Fig. 17

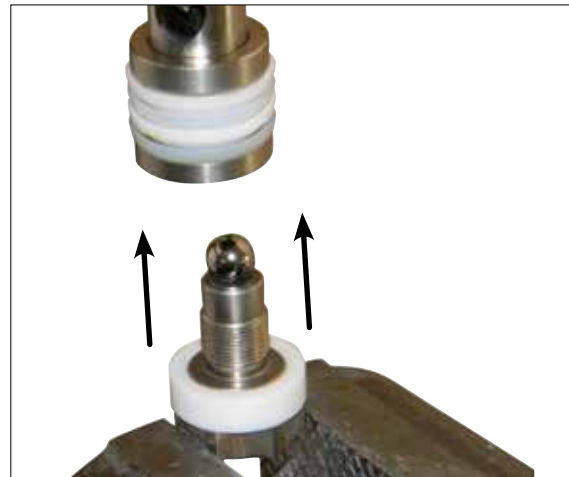

Fig. 17

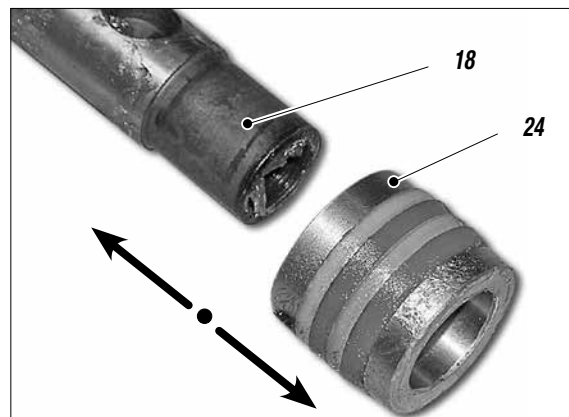

Fig. 18

- Fit the new gasket kit according to the component sequence shown in the figure. Check the scraper for wear (Ref. LA18648). Replace if necessary.

L O W E R



Fig. 19

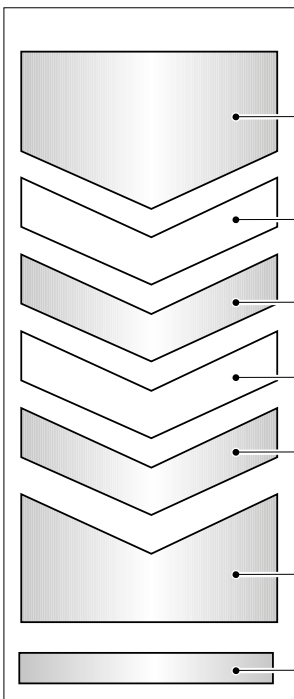
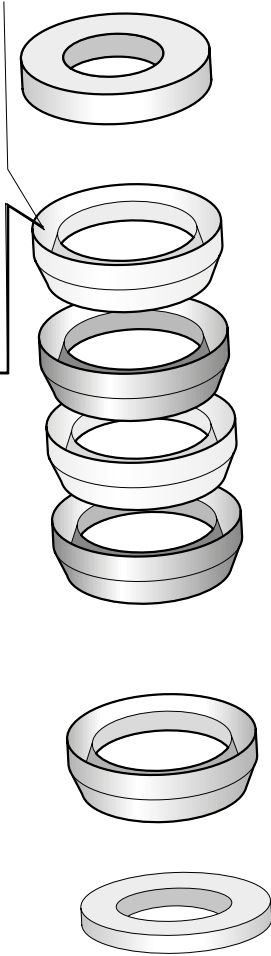

Steel male ring
Code LA18644

PTFE white
Code LA16117

Polyurethane red
Code LA16114

PTFE White
Code LA16117

Polyethylene grey
Code LA16136

Steel female ring
Code LA18645

PTFE scraper ring
Code LA18648

- Replace the grey polyethylene lipped gasket (25) for the valve piston.
- Refit according to the assembly order and the alignment of the lip (as shown).
Check the surfaces of the ball (26) and ball seating (27), and replace both if damaged.

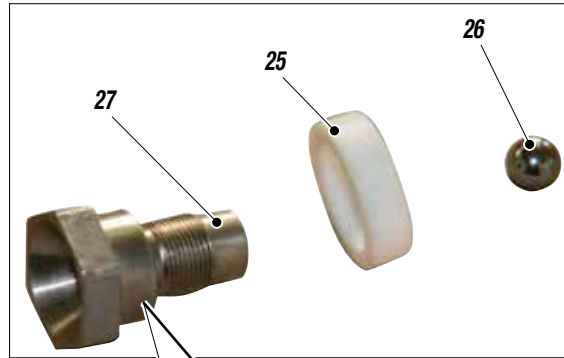
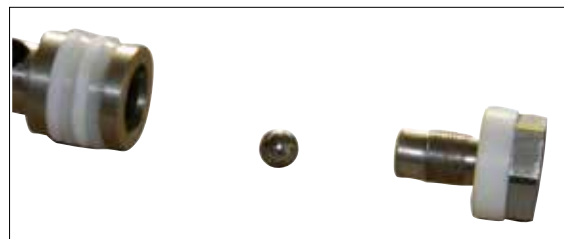

Fig. 20



- Assemble the components as shown.

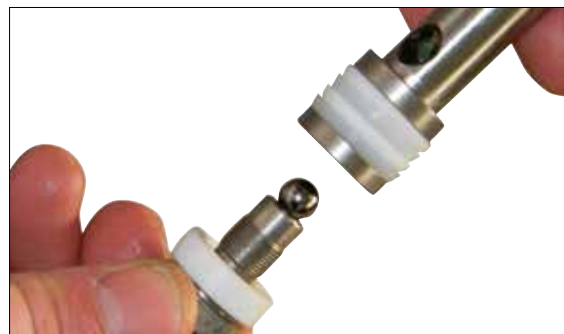

Fig. 21

- Lubricate the gaskets (28) and the stem. Vaseline is recommended for this task.

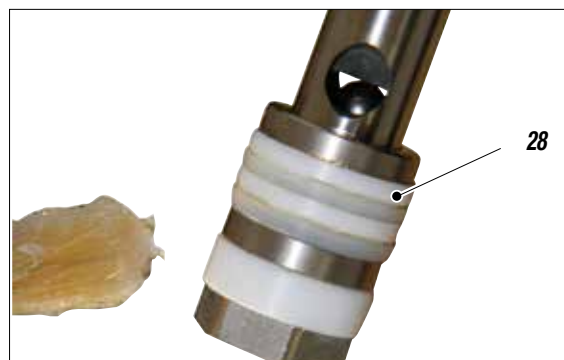

Fig. 21

- Insert the stem (18) into the housing (17) rotating it as you do so in order to allow it to slide more easily and to avoid damaging the upper gaskets.

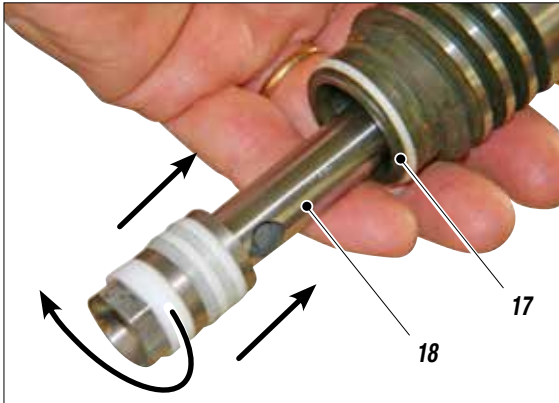

Fig. 22R

- Lubricate the O-ring (29) (Ref. LA16126) with grease, as shown. Vaseline is recommended for this task.

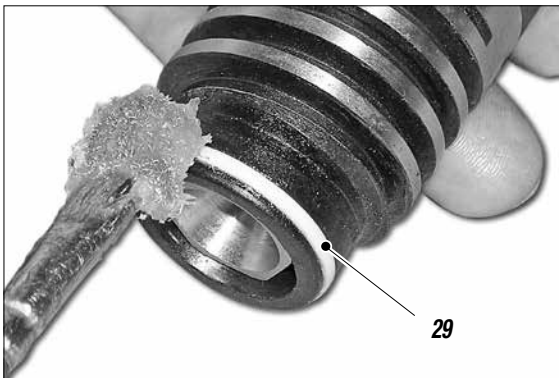

Fig. 23

- Put liquid PTFE on the first two turns (30) and (31) to avoid the two components coupled as shown from unscrewing.

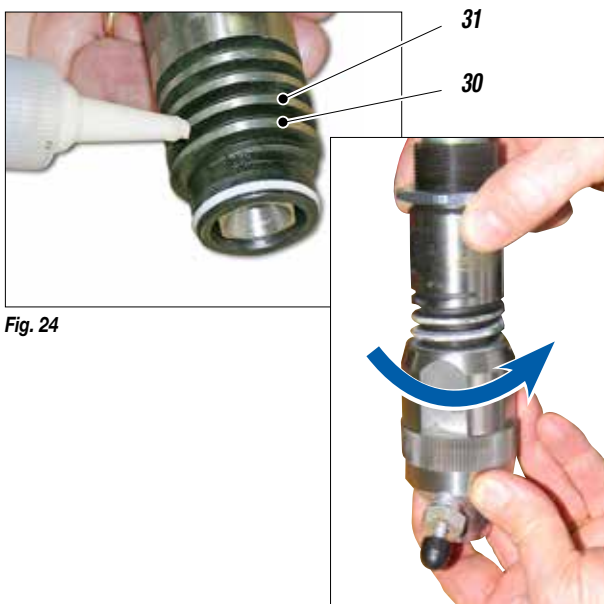

Fig. 24

- Use a 36 mm spanner to screw on the pump unit (9).

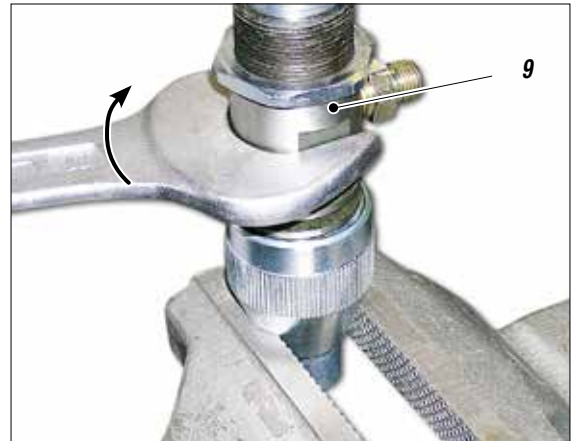

Fig. 25

- Make the piston stem (18) fitted previously complete a full stroke as shown.

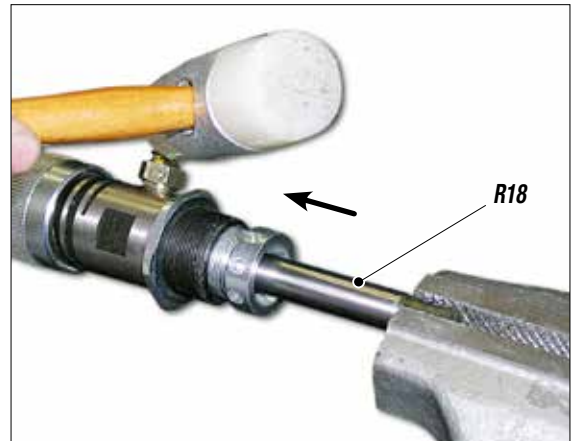

Fig. 26

- Use the pin (11) supplied to tighten the gasket compression ring nut (10). Close this until it is fully touching, without forcing.

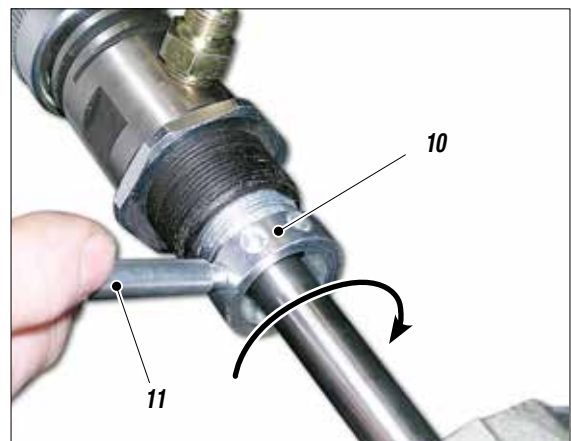

Fig. 27

CORRECT POSITIONING OF THE PUMP UNIT

Once the unit has been refitted, proceed as follows:

- Check the position of the con rod, which should be positioned at its lower stopping point.
- Put the entire pump unit (9) inside the reduction cover (32) as shown.



- Screw the entire pump unit onto the front template, making sure that the end of the stem is centred in relation to the groove in the con rod (33).
- Centre the two holes (con rod + stem) and insert the stopping pin (34) inside the con rod (33).
- Check that the closing spring (35) in the con rod (33) goes into the pin seating when closed (as shown).



Fig. 27

- Screw the entire pump unit (9) inside the reduction cover.
- Use a gauge to measure the gap between the base of the template and the start of the tightening groove.



The reference value (see drawing) must be 18 mm. The maximum tolerance accepted for correct operation is 21 mm maximum and 16 mm minimum.

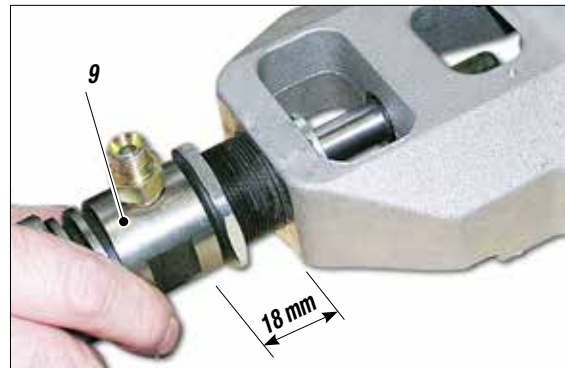

Fig. 28

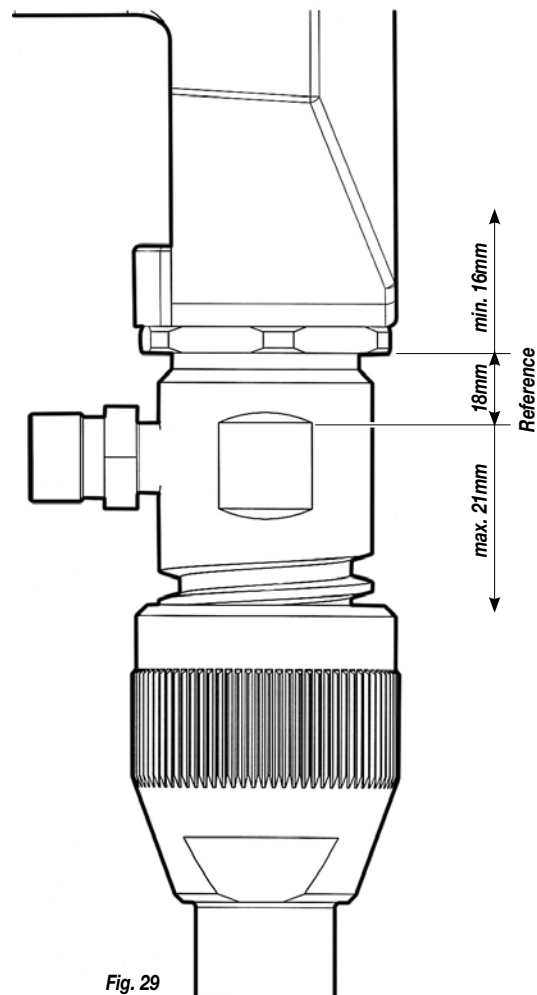

Fig. 29

- Once the unit has been positioned correctly, tighten the lock nut (36) hard against the front template. To tighten, use a 45 mm spanner.

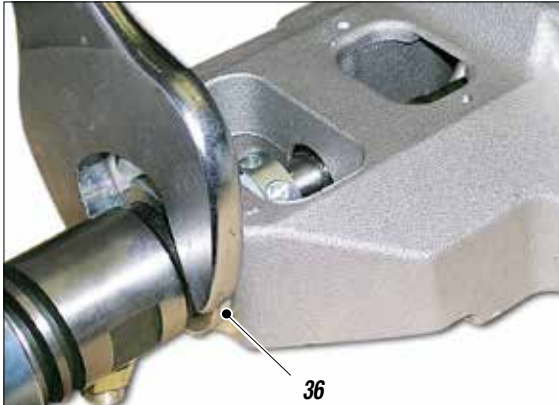

Fig. 30

- Close the inspection cover (2) again.



Fig. 31

- Fit the suction pipe. Put PTFE tape or liquid PTFE over the threaded part (37) before screwing it onto the foot valve.

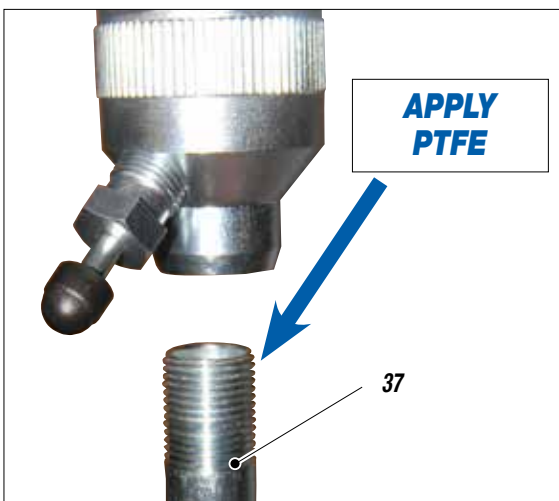

Fig. 32



For correct reassembly, see the exploded diagram for the pump unit, and invert the order used for disassembly.

REPLACEMENT OF THE BALL RELEASE GROUP SEAL

In case there is a loss of material from the ball release group (38), it is necessary to replace the gasket (39) as shown.



Fig. 33

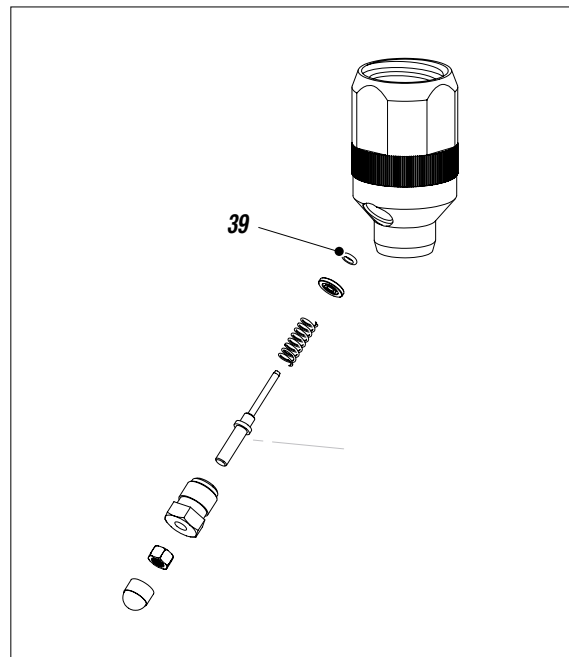

Fig. 31

S GLASS BEAD DISPENSER UNIT COMPONENTS (OPTIONAL)

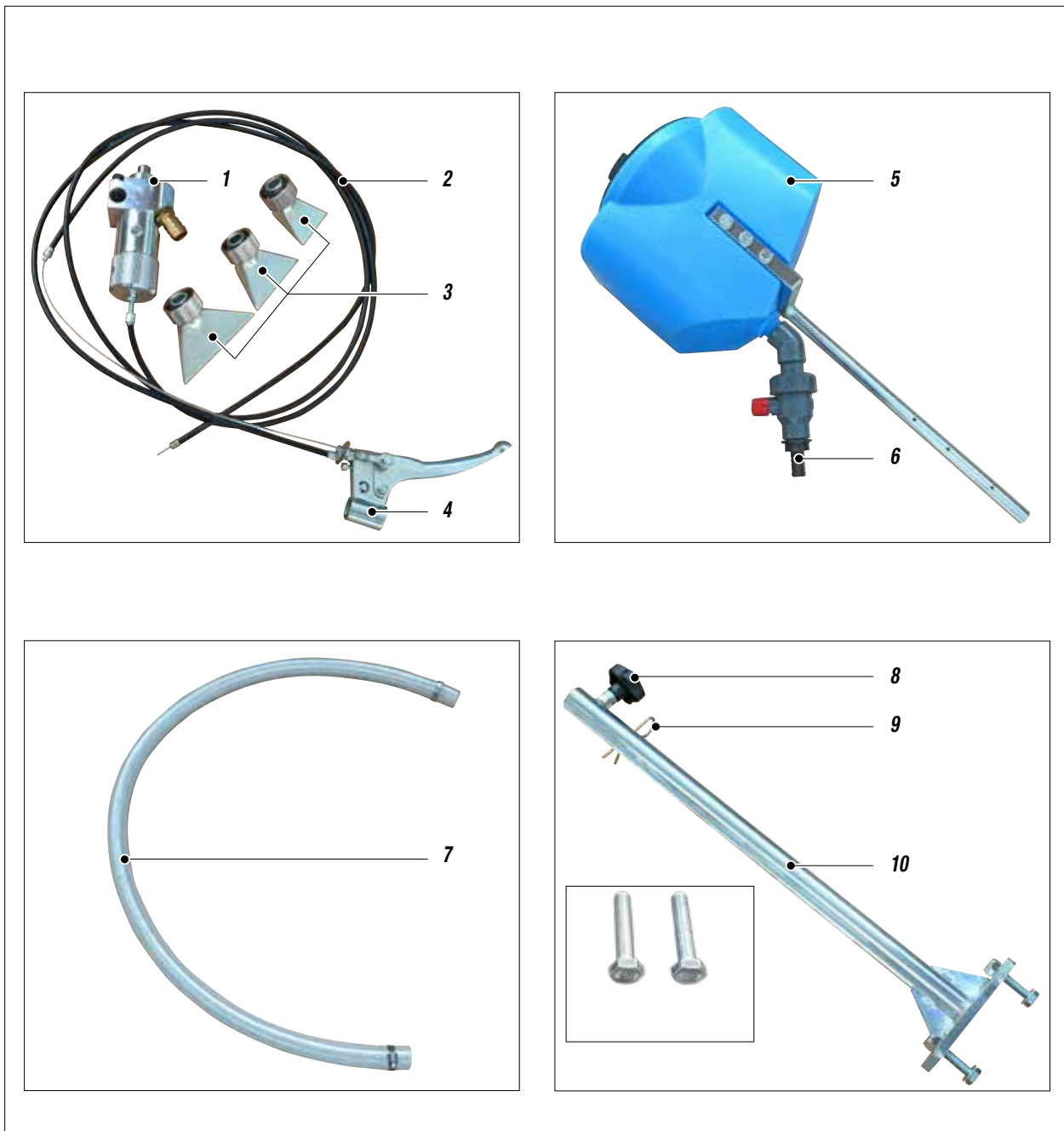

Fig. 2

Pos.	Descrizione
1	Glass bead gun
2	Wire
3	Brushes of different sizes
4	Control handle
5	Tank - 11 lt
6	Fitting with ON/OFF valve

Pos.	Descrizione
7	Bead feed tube
8	Knob
9	Height adjustment pin
10	Tank support bracket
11	Bracket fixing screws - increased length

T GLASS BEAD DISPENSER UNIT ASSEMBLY (OPTIONAL)

1 SCREW REPLACEMENT

Necessary tools and equipment



Procedure

- 1.1 Remove the two screws (1a) from the swivel wheel and replace them with two longer screws (1b).

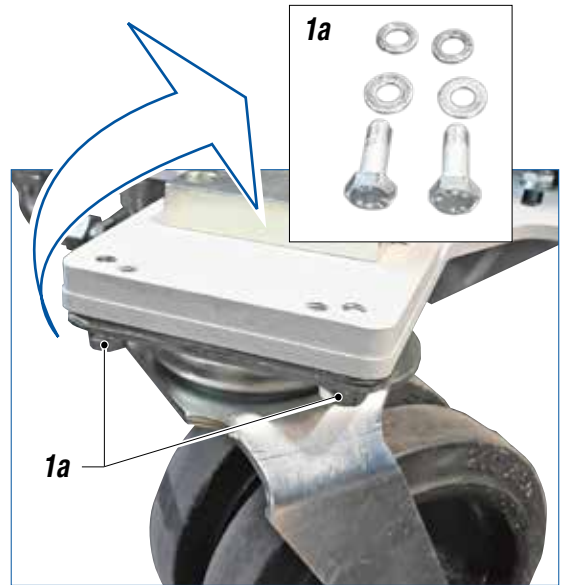
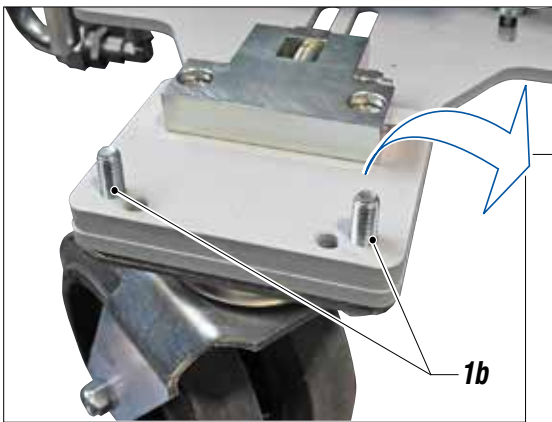

2 TANK SUPPORT BRACKET POSITIONING

Necessary tools and equipment



Procedure

- 2.1 Position the tank support bracket (2a), securing its position with self-locking nuts (2b).

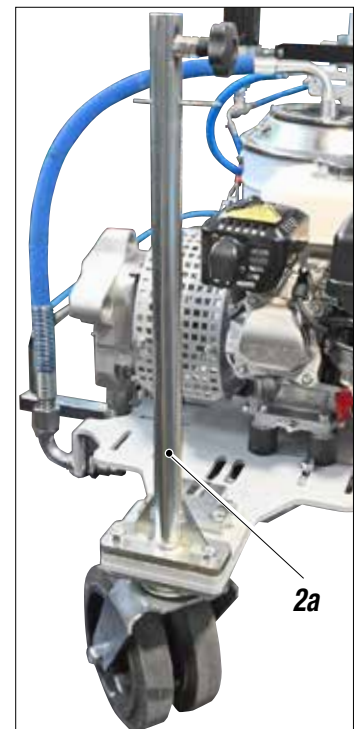
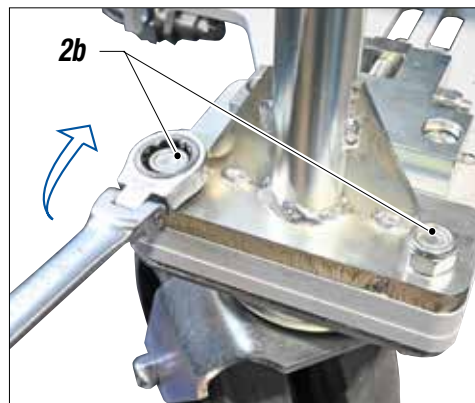
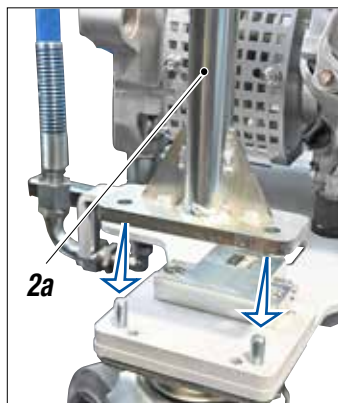

3 TANK INSTALLATION

Necessary tools and equipment

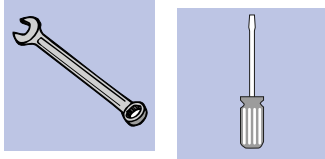

Procedure

- 3.1 Remove the cotter pin (3a) and unscrew the knob (3b) without removing it.
- 3.2 Position the tank (3c) at the desired height (adjustable with the pin), ensuring to keep the fitting (3d) gun-side oriented.
- 3.3 Reposition the pin (3e) and secure the tank by screwing the knob and lock nut back in place (3f).
- 3.4 Connect the bead feed tube (3g) securing its position with a clamp (3h)

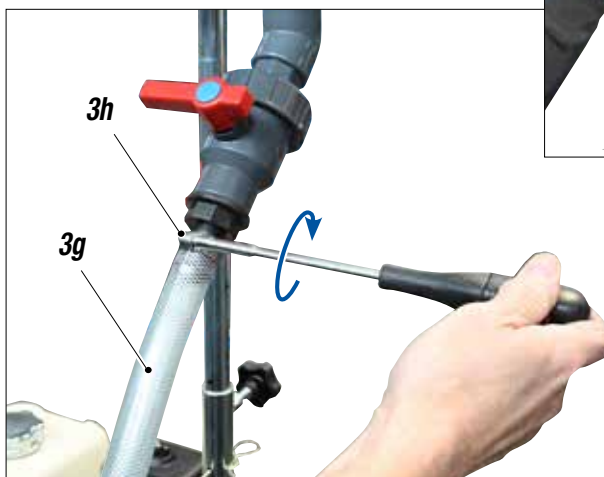
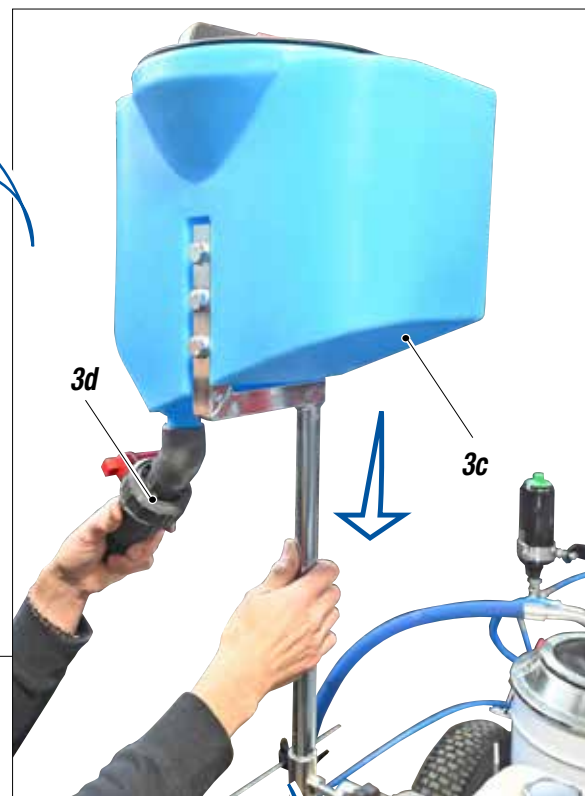
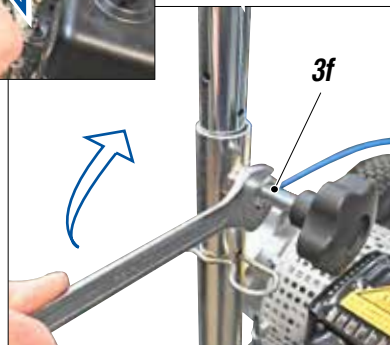
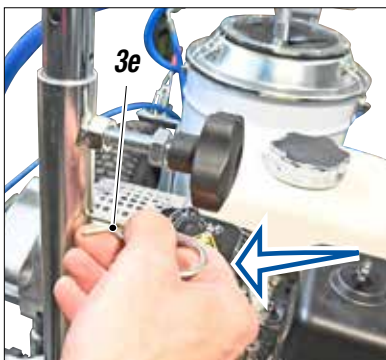
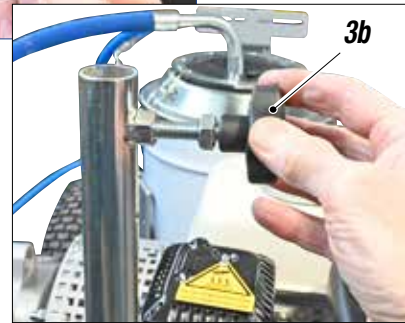
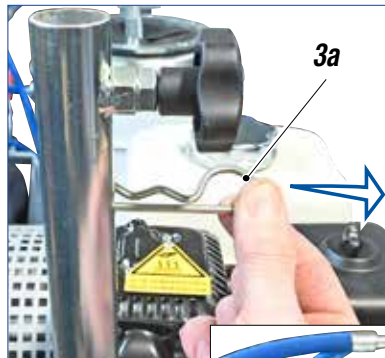

4 GUN HANDLE REPLACEMENT

Necessary tools and equipment

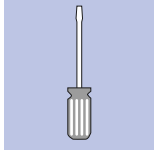

Procedure

- 4.1 Remove the gun control handle (4a) loosening the screws (4b)
- 4.2 Pull out the cable (4c) along its entire length until reaching the gun
- 4.3 Remove the rubber grip (4d)
- 4.4 Insert the new handle (4e) and tighten the screws (4f)
- 4.5 Reposition the grip (4d)

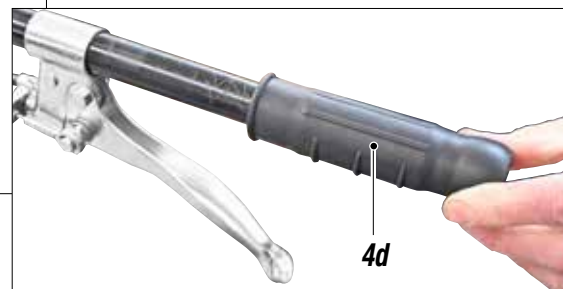
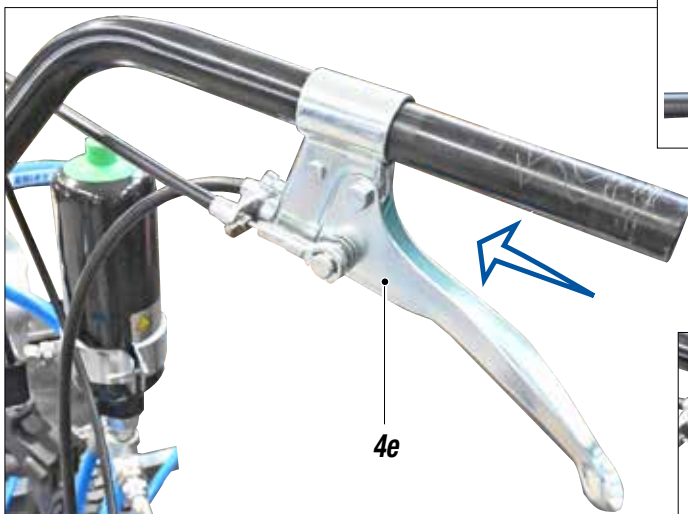
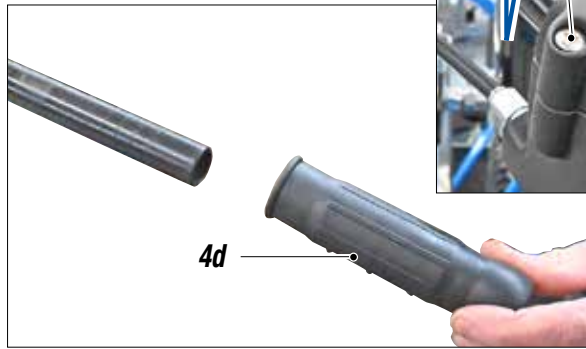
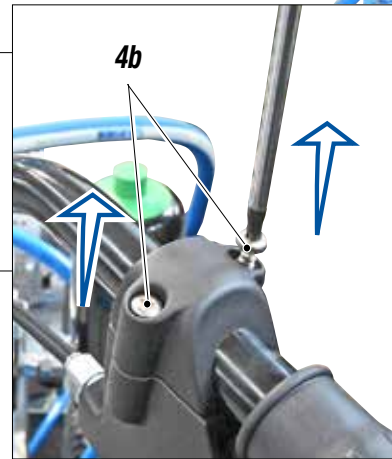
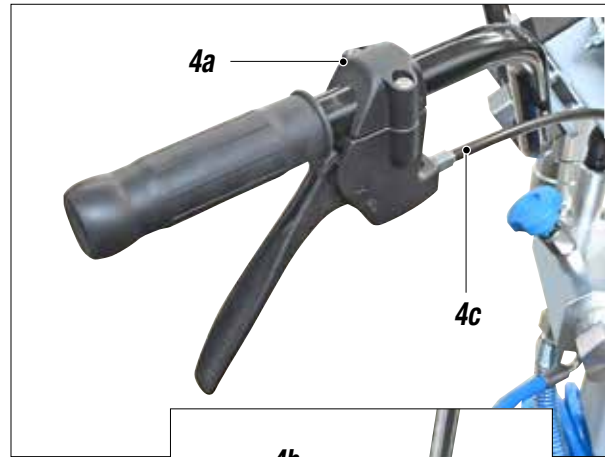

5 GUN REMOVAL

Necessary tools and equipment

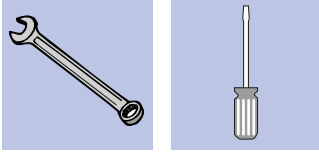

Procedure

- 5.1 Unscrew the screws (5b) and remove the gun (5a)
- 5.2 Unscrew the screw (5d) and remove the wire guide block (5c)
- 5.3 Remove the wire (5e)

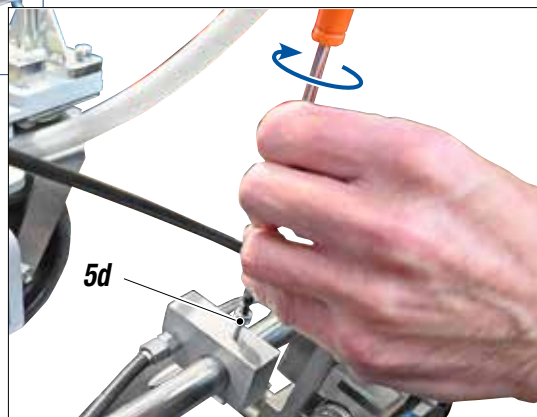
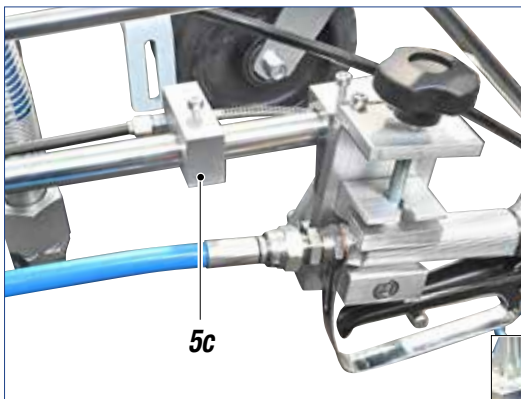
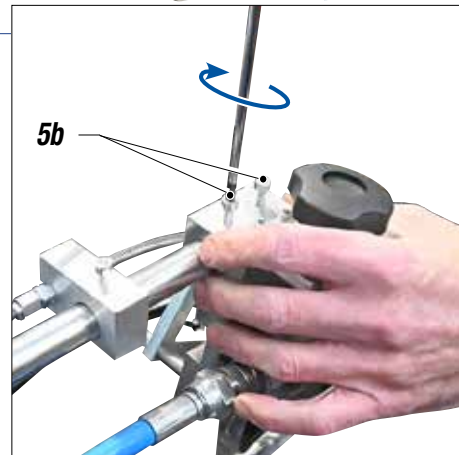
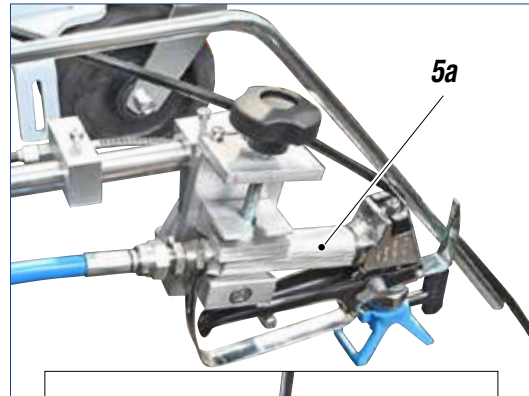

6 GLASS BEAD DISPENSER INSTALLATION

Necessary tools and equipment

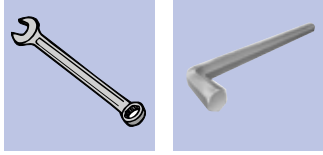

Procedure

- 6.1 Position the glass bead dispenser (6a) on the gun holder arm, tightening the screws and nuts (6b)
- 6.2 Reposition the wire guide block (6c) and the gun (6d) on the gun holder arm
- 6.3 Insert the new paint gun control wire (6e)
- 6.4 Reposition the spring (6f) and block the wire with the wire clamp (6g)

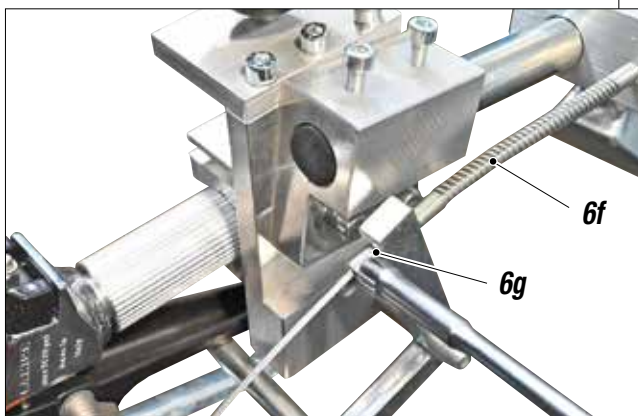
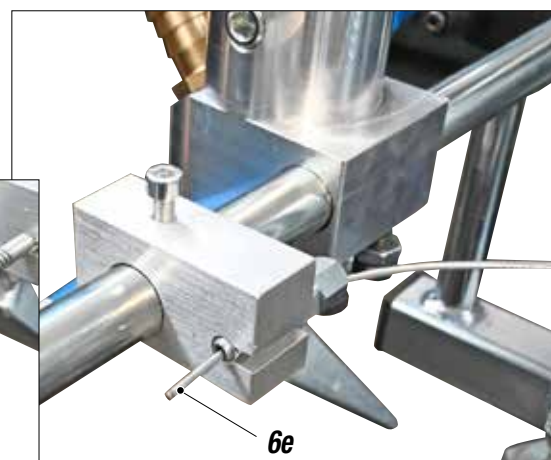
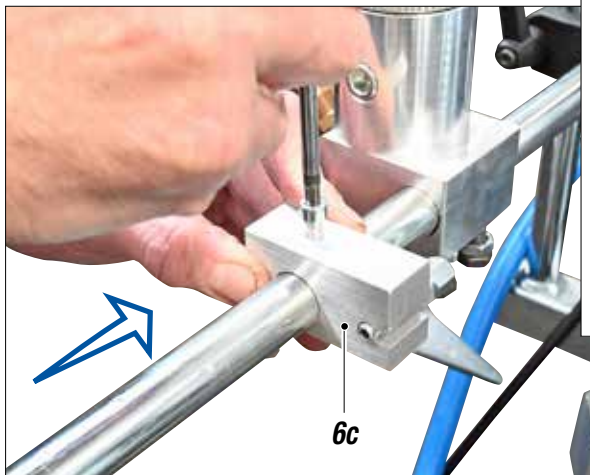
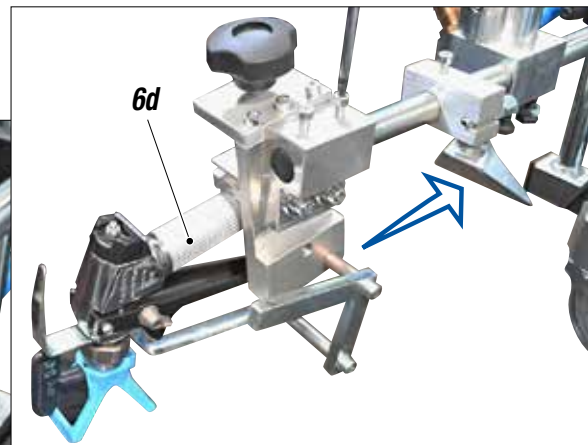
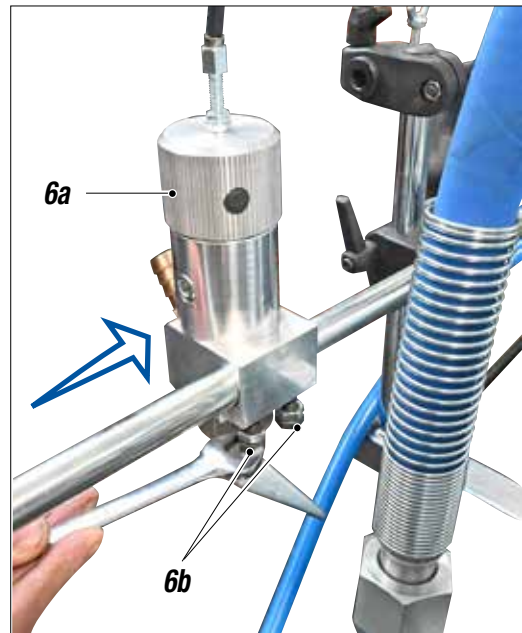

7 GLASS BEAD FEED TUBE CONNECTION

Necessary tools and equipment

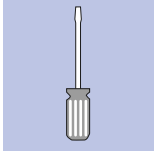

Procedure

- 7.1 Connect the glass bead feed tube (7a) locking the clamp (7b)

NOTE

The bead dispenser control cable is supplied by the manufacturer registered to its maximum stroke opening. However, it is possible to adjust the opening of the bead dispenser by acting on the adjustment screw (7c).

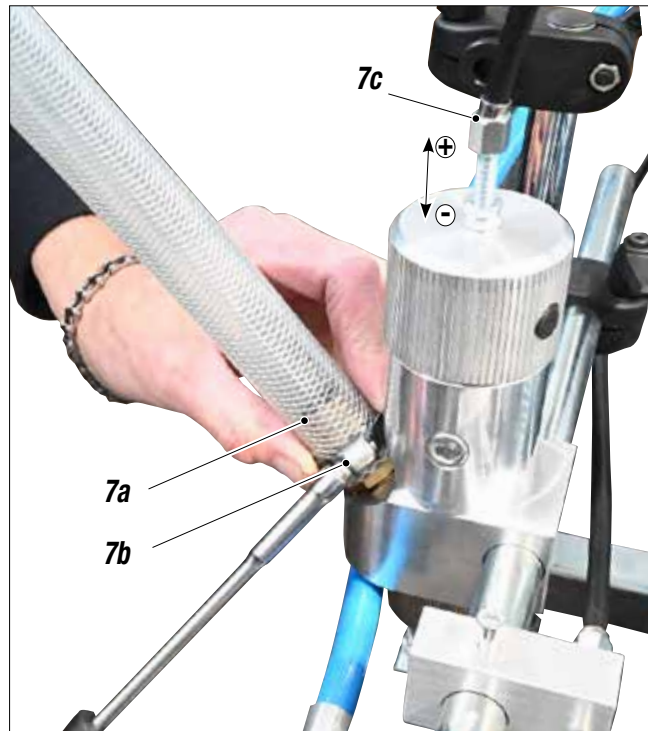

U PROBLEMS AND SOLUTIONS

Problem	Cause	Solution
The equipment does not start	On/Off switch disconnected;	Ensure the On/Off switch is on the "on" position and turn clockwise the pressure control knob;
	Lack of gasoline;	Add gasoline;
	Breakdown of motor electric control box;	Verify and replace it, if necessary;
	The line of material coming out of the pump is already under pressure;	Open the drain valve to release pressure in the circuit;
	The product is solidified inside the pump;	Open the drain valve to release pressure in the circuit and stop the machine. Disassemble the pumping group and the pressure transmitter and clean;
The equipment does not suck the product	Suction filter clogged;	Clean or replace it;
	Suction filter too fine;	Replace it with a larger-mesh filter (with very dense products, remove the filter);
	Product output valve closed;	Open the product output valve;
	The equipment sucks air;	Check the suction pipe;
The equipment sucks but does not reach the pressure desired	Lack of product;	Add the product;
	The equipment sucks air;	Check the suction pipe;
	The recirculating-safety valve is open;	Close the recirculating-safety valve;
	The gaskets of the pumping group are worn;	Replace the gaskets;
	Suction or delivery valve dirty;	Disassemble the pumping group;
When pressing the trigger, the pressure lowers considerably	Nozzle too big or worn;	Replace it with a smaller one;
	The product is too dense;	Dilute the product, if possible;
	The filter of the gun-butt is too fine;	Replace it with a larger-mesh filter;
The pressure is normal but the product is not atomized Leakage from the seal-tightening screw	The nozzle is partially clogged;	Clean or replace it;
	The product is too dense;	Dilute the product, if possible;
	The filter of the gun-butt is too fine;	Replace it with a larger-mesh filter;
The atomization is imperfect	The nozzle is worn;	Replace it;
When releasing the trigger of the gun, the equipment does not stop (the motor runs slowly and the piston rod keeps on going up and down)	The gaskets of the pumping group are worn;	Replace the gaskets;
	Suction or delivery valve dirty;	Disassemble the pumping group and clean;
	Recirculating-safety valve defective.	Verify and replace it, if necessary.



Always close the air compressed supply and unload the plant pressure before performing any check or replacement of pump parts (see "correct procedure of decompression").

Intentionally blank page

SPARE PARTS

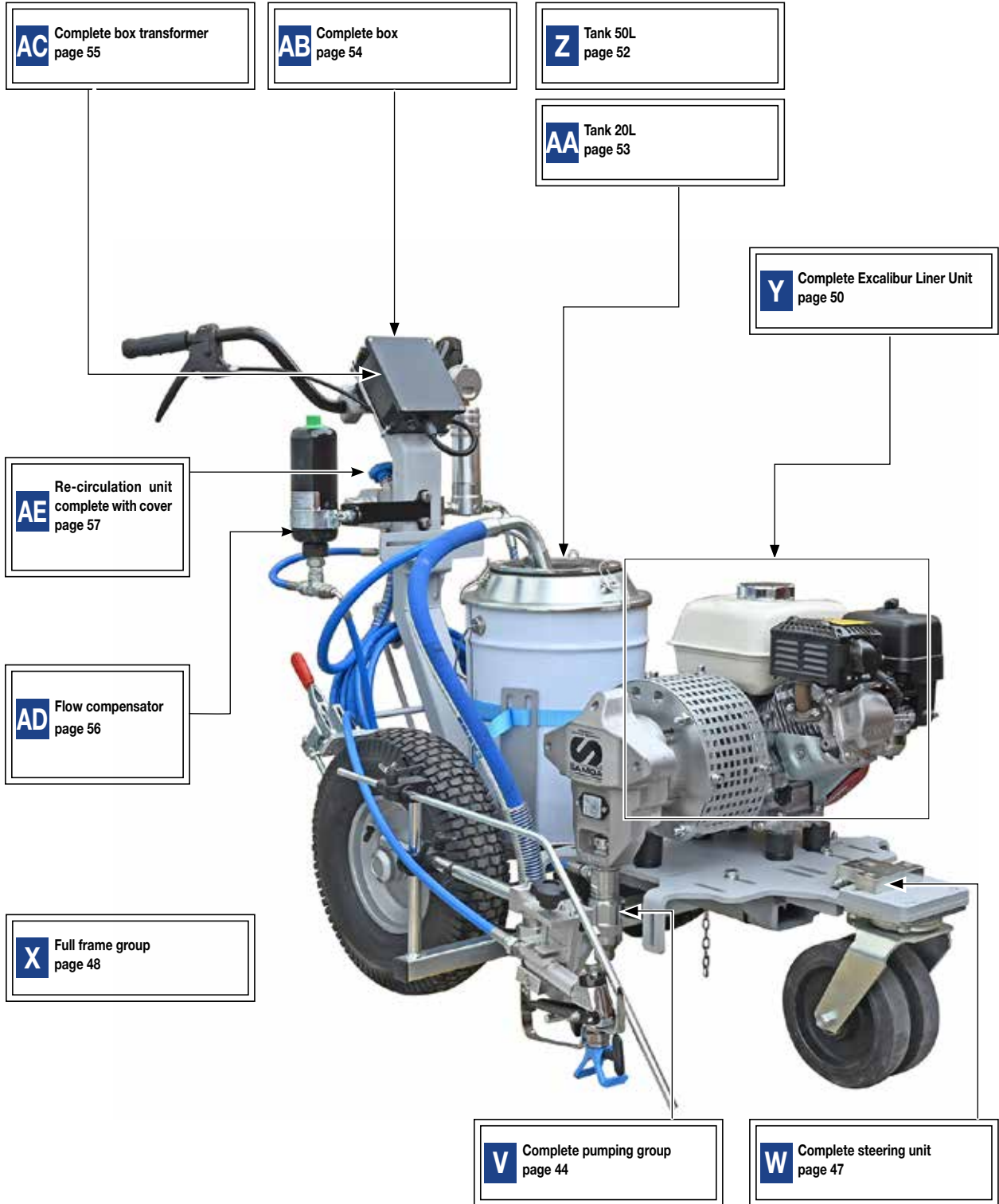

V COMPLETE PUMPING GROUP REF. LA56562

WARNING: Always indicate code and quantity for each part required.

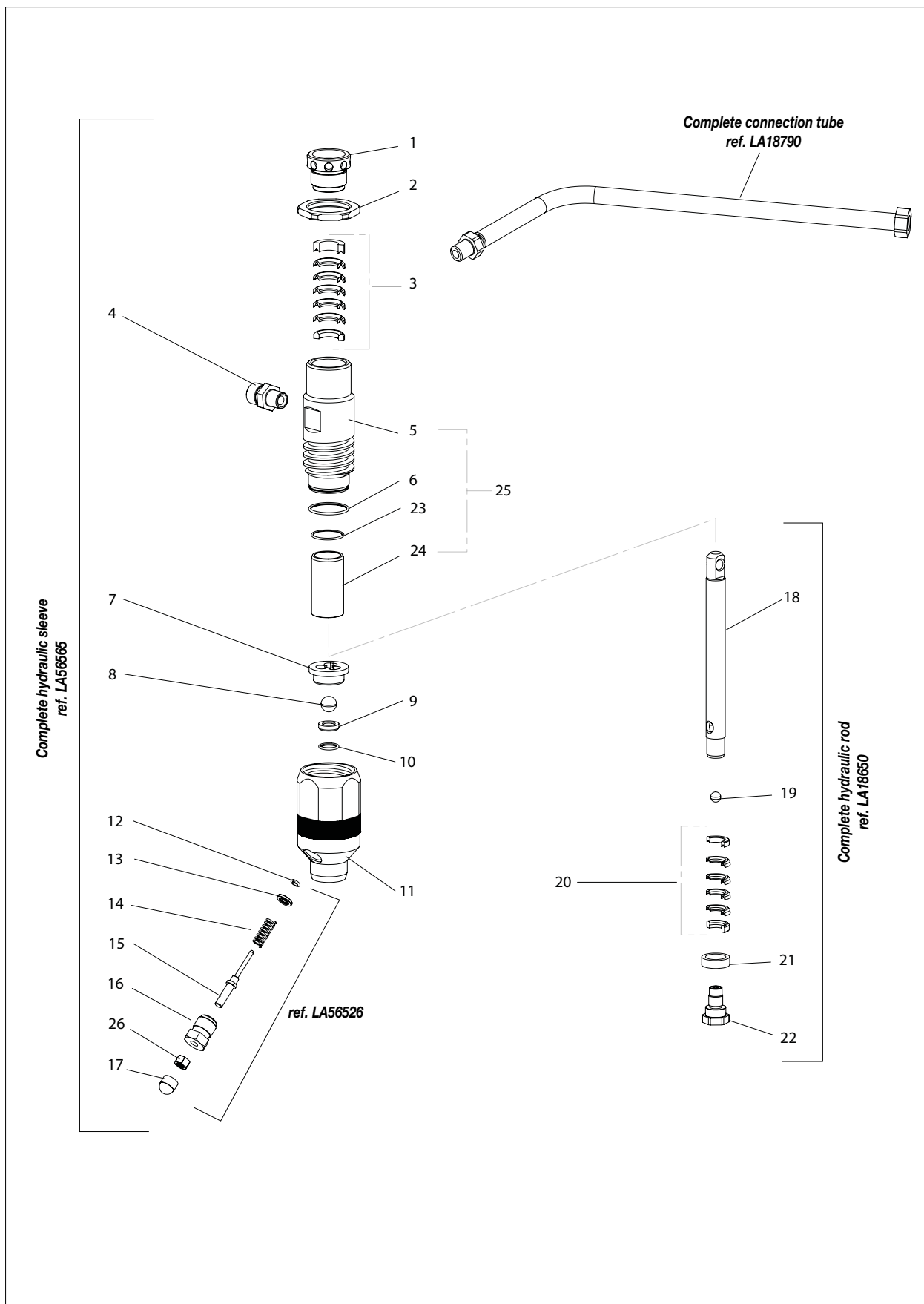

Pos.	Code	Description
0	LA56562	Complete hydraulic group
1	LA16109	Ring packing
2	LA16127	Locking nut
3	LA16105	Upper gaskets kit
4	LA96208/1	Fitting
5	LA18640	Sleeve
6	LA16126	OR 2112
7	LA18642	Ball guide
8	LA33028	Ball
9	LA91018	Ball housing
10	LA18643	Seal
11	LA56536	Foot valve body

Pos.	Code	Description
12	LA18553	OR 2012
13	LA56540	Disk
14	LA9288	Spring
15	LA56547	Releasing rod
16	LA56538	Guiding bushing
17	LA56541	Rod rubber
18	LA18652	Piston rod
19	LA16130	Ball
20	LA18651	Lower gaskets kit
21	LA18648	Scraper ring
22	LA18655	Complete rod valve

LA40107: Complete pump repair kit

Pos.	Code	Description
3	LA16105	Upper gaskets kit
5	LA18640	Sleeve
6	LA16126	OR 2112
8	LA33028	Ball
10	LA18643	Seal

LA40106: Pump maintenance kit

Pos.	Code	Description
3	LA16105	Upper gaskets kit
6	LA16126	OR 2112
8	LA33028	Ball
10	LA18643	Seal

LA18854: Foot valve kit

Pos.	Code	Description
8	LA33028	Ball
9	LA91018	Ball housing
10	LA18643	Seal

LA18855: Gasket kit lower + higher

Pos.	Code	Description
3	LA16105	Upper gaskets kit
20	LA18651	Lower gaskets kit

GASKETS ASSEMBLY

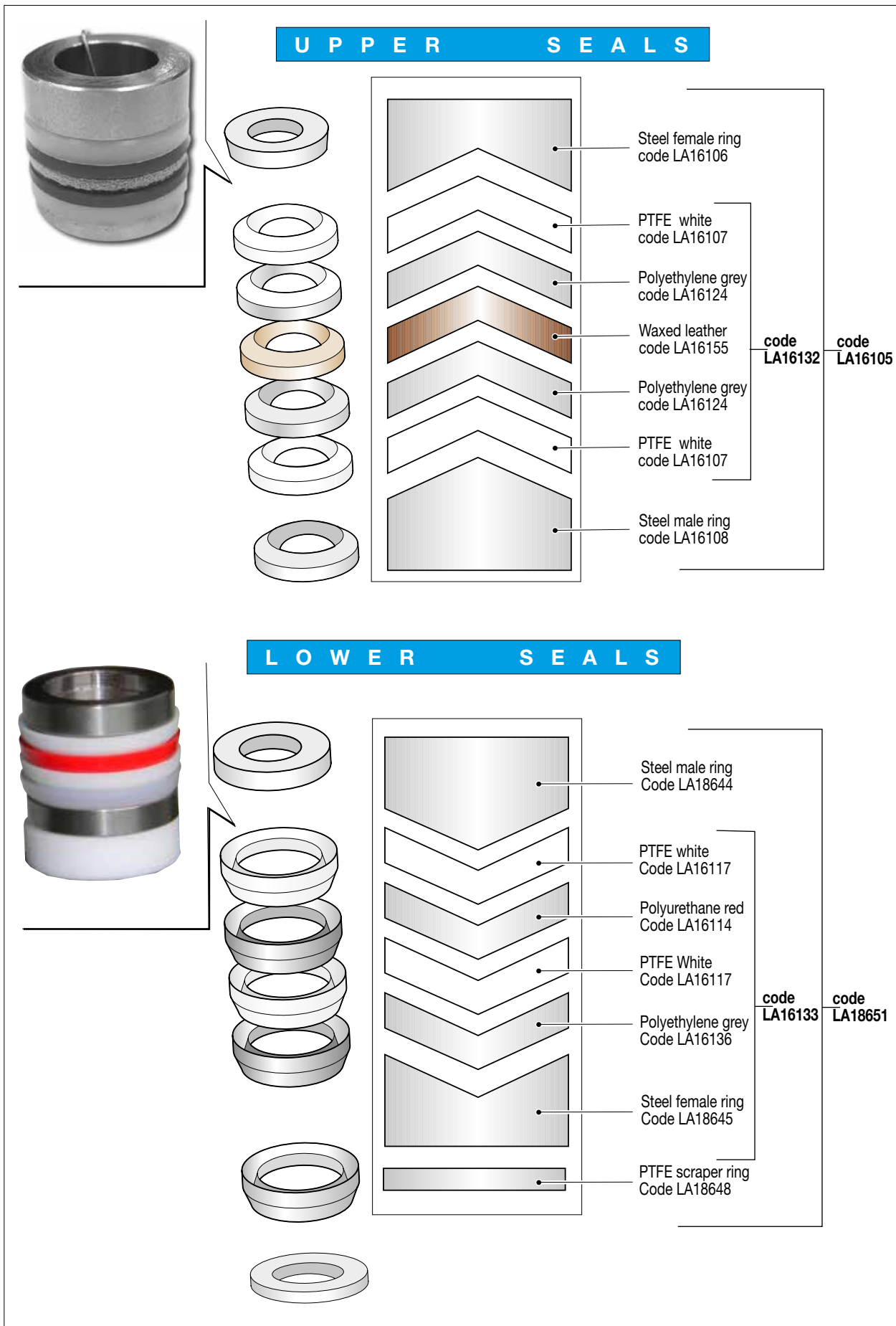

W COMPLETE STEERING UNIT REF. LA4876

WARNING: Always indicate code and quantity for each part required.

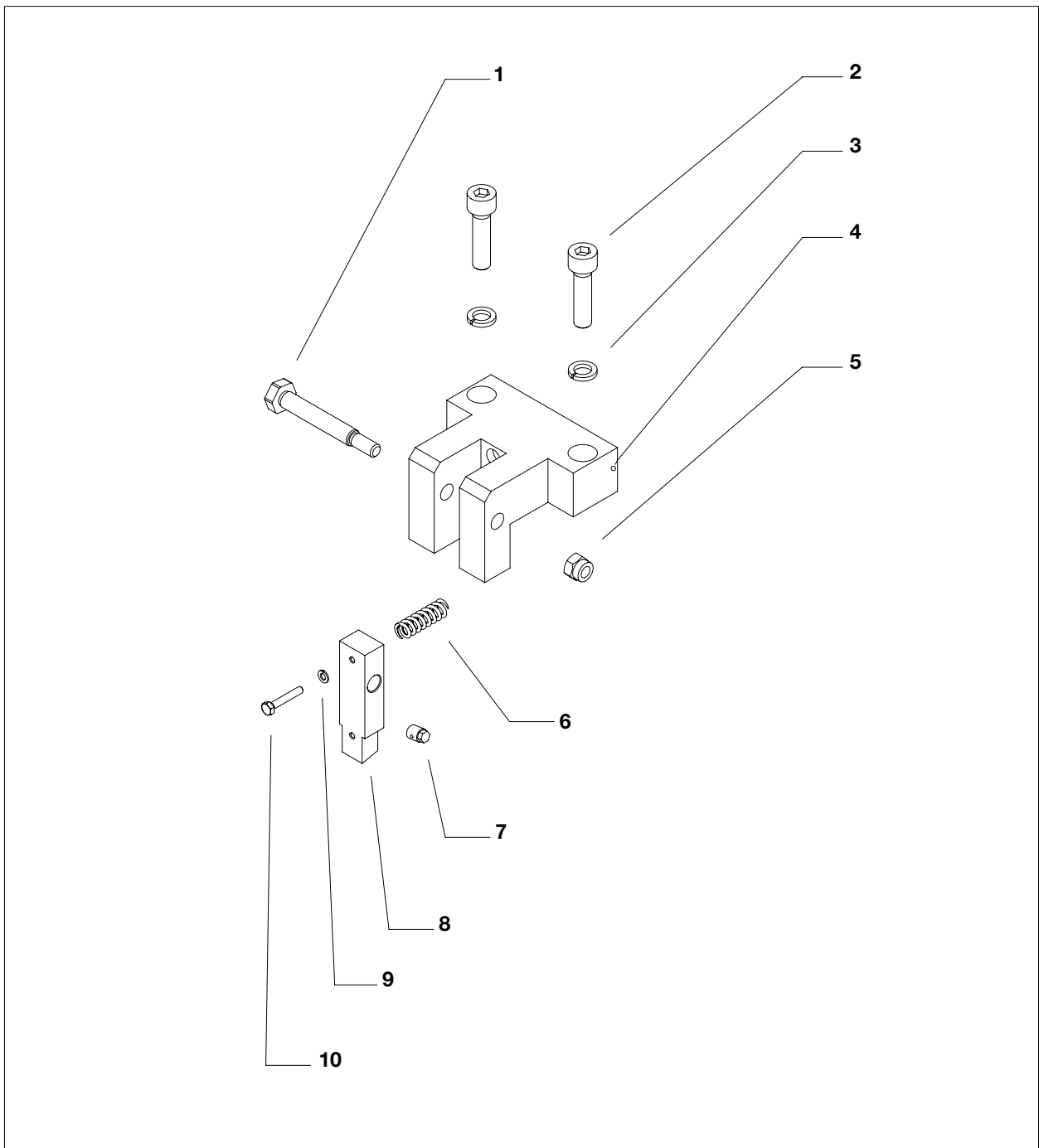

Pos.	Code	Description
-	LA4876	Complete steering unit
1	LA4735	Screw
2	LA95068	Screw
3	LA330058	Washer
4	LA4737	Base
5	LA3637	Nut

Pos.	Code	Description
6	LA9238	Spring
7	LA4253	Wire stopper
8	LA4875	Pin
9	LA5339	Washer
10	LA4739	Screw

X FULL FRAME REF. LA4874

WARNING: Always indicate code and quantity for each part required.

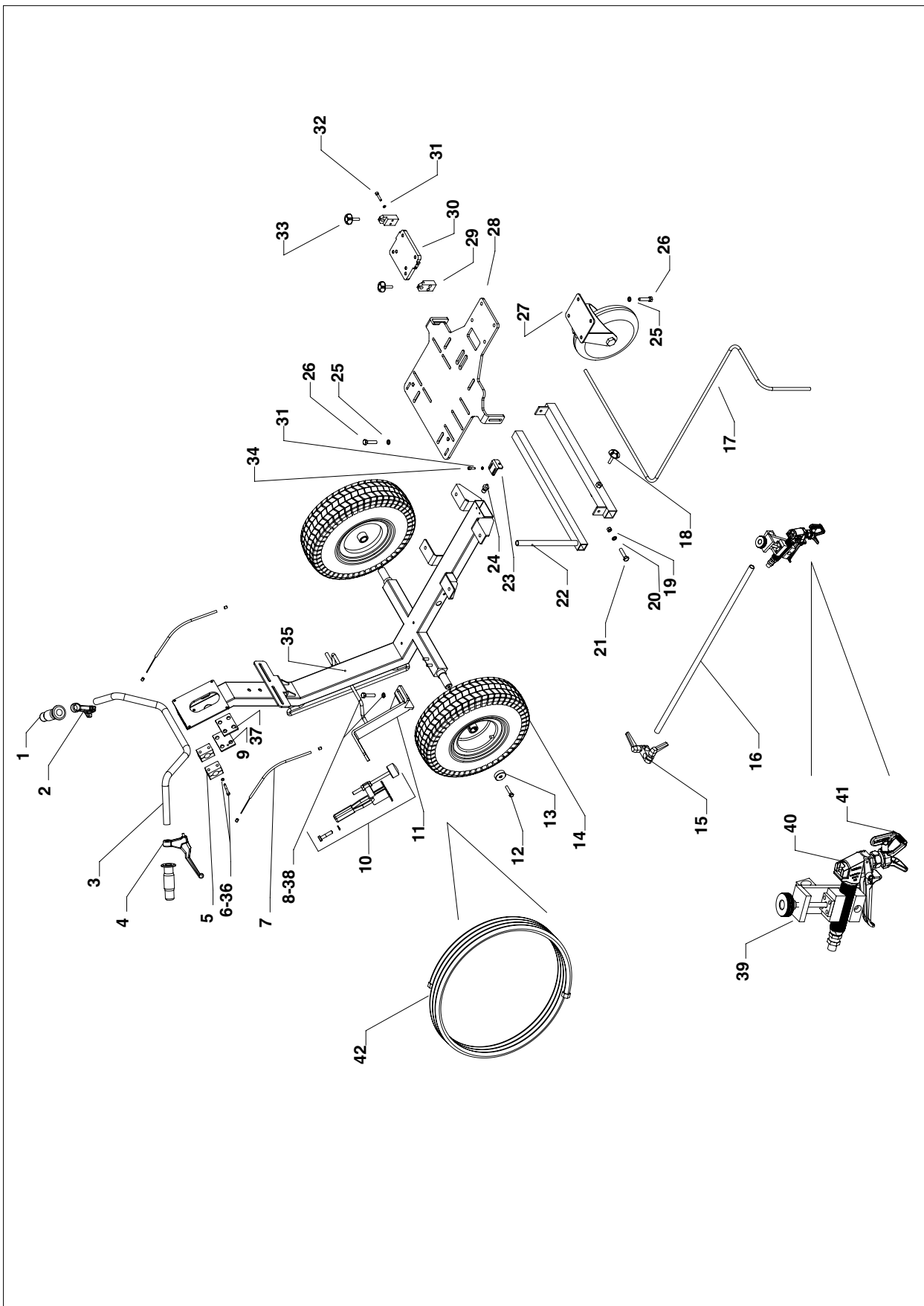

Pos.	Code	Description
-	LA4874	Full frame group
1	LA4256	Handle
2	LA4463	Lever
3	LA4865	Handlebar
4	LA4464	Right Lever
5	LA4866	Block
6	LA7043	Screw
7	LA4873	Complete cable
8	LA81032	Screw
9	LA4825	Plate
10	LA4868	Complete brake
11	LA4867	Brake support
12	LA8371	Screw
13	LA4492	Washer
14	LA4461	Wheel
15	LA4869	Block
16	LA4450	Rod
17	LA26020	Rod
18	LA4490	Block
19	LA3637	Nut
20	LA34009	Washer
21	LA81032	Screw

Pos.	Code	Description
22	LA4429	Gun support
23	LA4870	Plating
24	LA4265	Wire stopper
25	LA33005	Washer
26	LA95068	Screw
27	LA4260	Pivoting wheel
28	LA4871	Plate
29	LA4449	Support
30	LA4872	Plate
31	LA32005	Washer
32	LA3037	Screw
33	LA4255	Block
34	LA91062	Screw
35	LA4864	Frame
36	LA32005	Washer
37	LA4824	Plate
38	LA34009	Washer
39	LA4448	Complete spray gun support unit
40	LA11200	Complete spray gun AT250
41	LA4833	Fast Clean small Liner accessory
42	LA35018	Compensation tube 3/16 10m

Y COMPLETE EXCALIBUR LINER UNIT REF. LA4877

WARNING: Always indicate code and quantity for each part required.

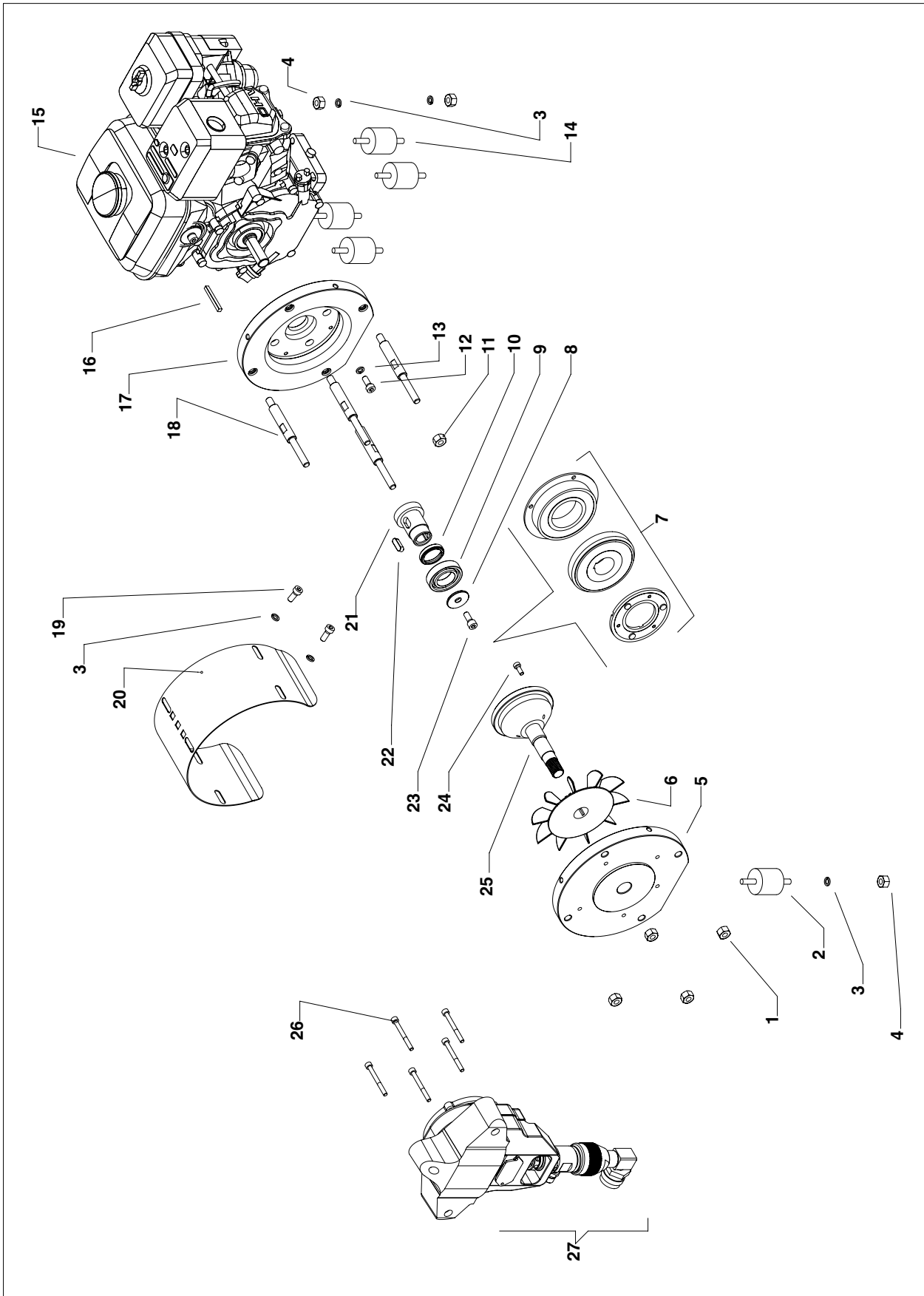

Pos.	Code	Description
-	LA4877	Complete Excalibur Liner unit
1	LA96080	Nut
2	LA700711	Vibration-damping pad
3	LA34009	Washer
4	LA3637	Nut
5	LA4879	Reduction flange
6	LA4880	Fan
7	LA4416	Complete clutch
8	LA4882	Washer
9	LA4883	Bearing
10	LA4884	Spacer
11	LA95158	Nut
12	LA54004	Screw
13	LA32005	Washer

Pos.	Code	Description
14	LA700150	Vibration-damping pad
15	-	Motor
16	LA18188	Tab
17	LA4887	Flange
18	LA4886	Tightening rod
19	LA96031	Screw
20	LA4888	Cover
21	LA4885	Bush
22	LA30656	Tab
23	LA18192	Screw
24	LA54004	Screw
25	LA4881	Pinion
26	LA21556	Screw
27	LA4878	Excalibur Liner reduction unit

Z COMPLETE 50L TANK REF. LA4895

WARNING: Always indicate code and quantity for each part required.

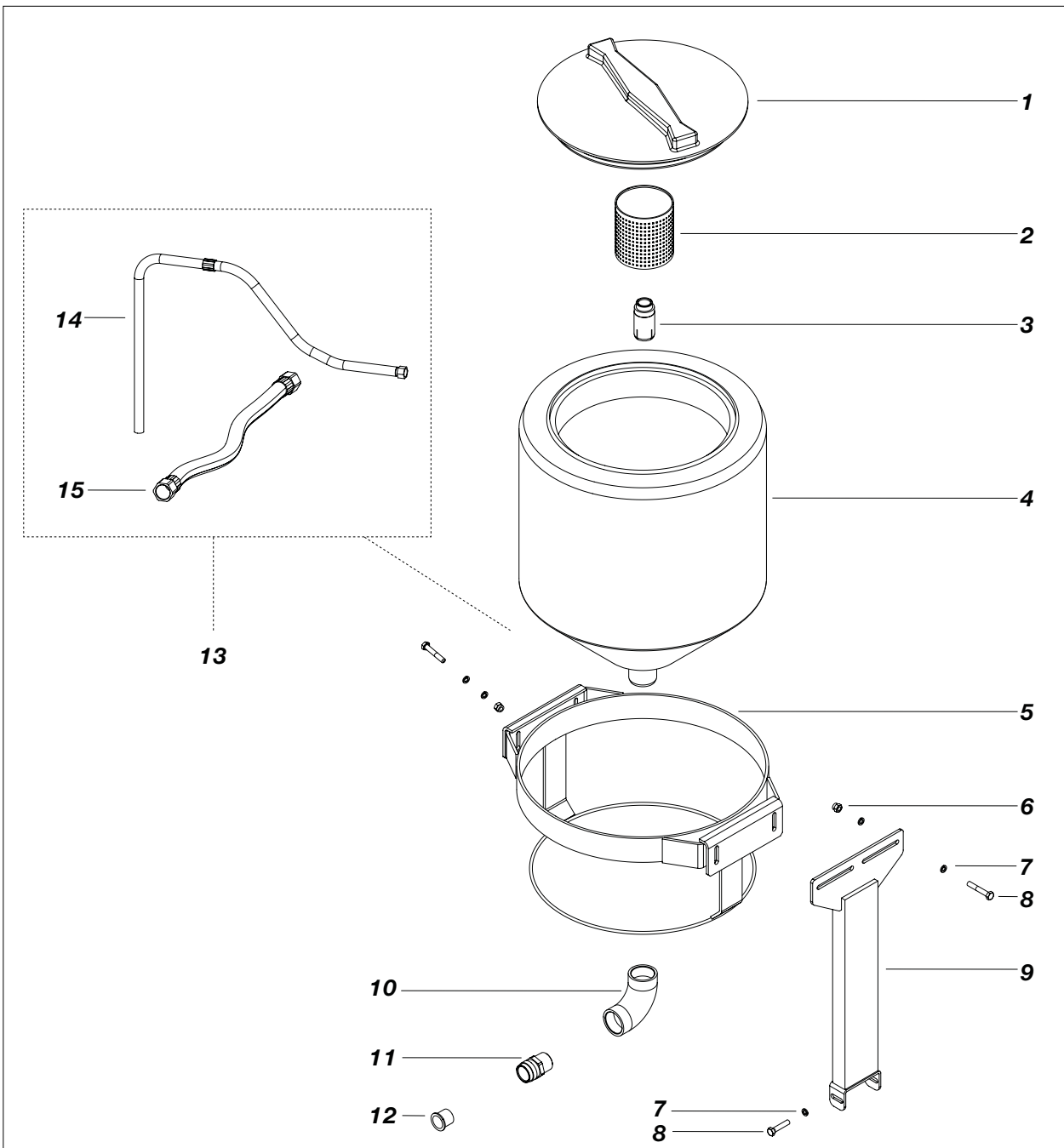

Pos.	Code	Description
-	LA4895	Complete 50L Tank
1	LA18249/1	Cover
2	LA85014	Filter
3	LA18231	Support
4	LA18249	50L Tank
5	LA18246	Support
6	LA52017	Nut
7	LA34009	Washer

Pos.	Code	Description
8	LA901568	Screw
9	LA4894	Support
10	LA18215	Elbow
11	LA95032	Union
12	LA96099	Seal
13	LA4834	Complete suction+recirculation system
14	LA16609	Recirculation tube
15	LA18223/2	Suction tube

AA COMPLETE 20L TANK REF. LA4890

WARNING: Always indicate code and quantity for each part required.

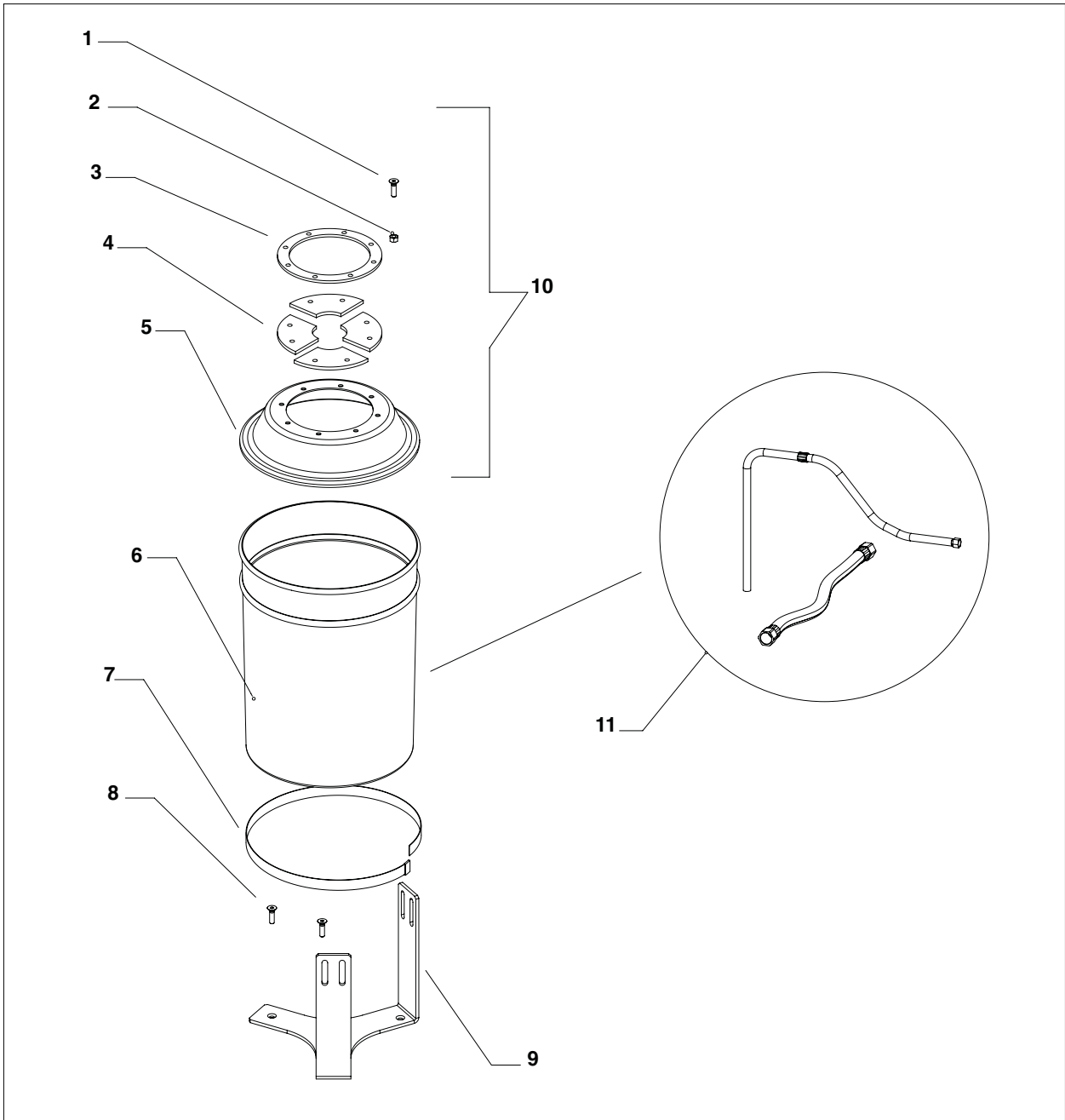

Pos.	Code	Description
-	LA4890	Complete 20L Tank
1	LA4314	Screw
2	LA52017	Nut
3	LA4308	Ring
4	LA4309	Rubber
5	LA4109	Cover

Pos.	Code	Description
6	LA4064	20l Tank
7	LA4274	Belt
8	LA69014	Screw
9	LA4250	Base
10	LA4111	Cover complet
11	LA16676	Complete suction+output system

AB COMPLETE BOX REF. LA4896

WARNING: Always indicate code and quantity for each part required.

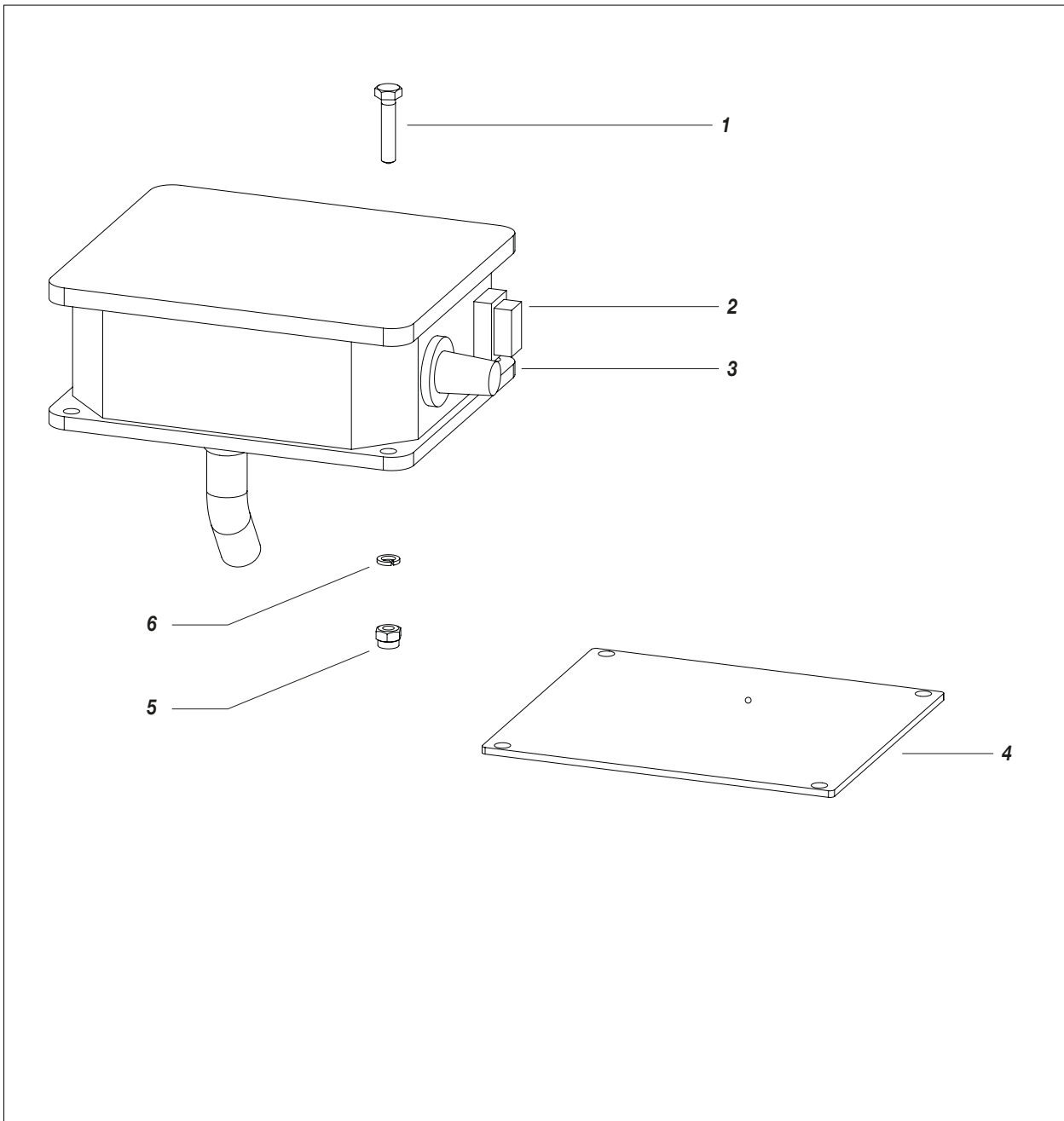

Pos.	Code	Description
-	LA4896	Complete box
1	LA91062	Screw
2	LA5933	Switch ON/OFF
3	LA30549	Potentiometer

Pos.	Code	Description
4	LA4923	Closure plate
5	LA8042	Nut
6	LA32005	Washer
7	LA16850	Warning stickers

AC COMPLETE BOX TRASFORMER REF. LA4845

WARNING: Always indicate code and quantity for each part required.

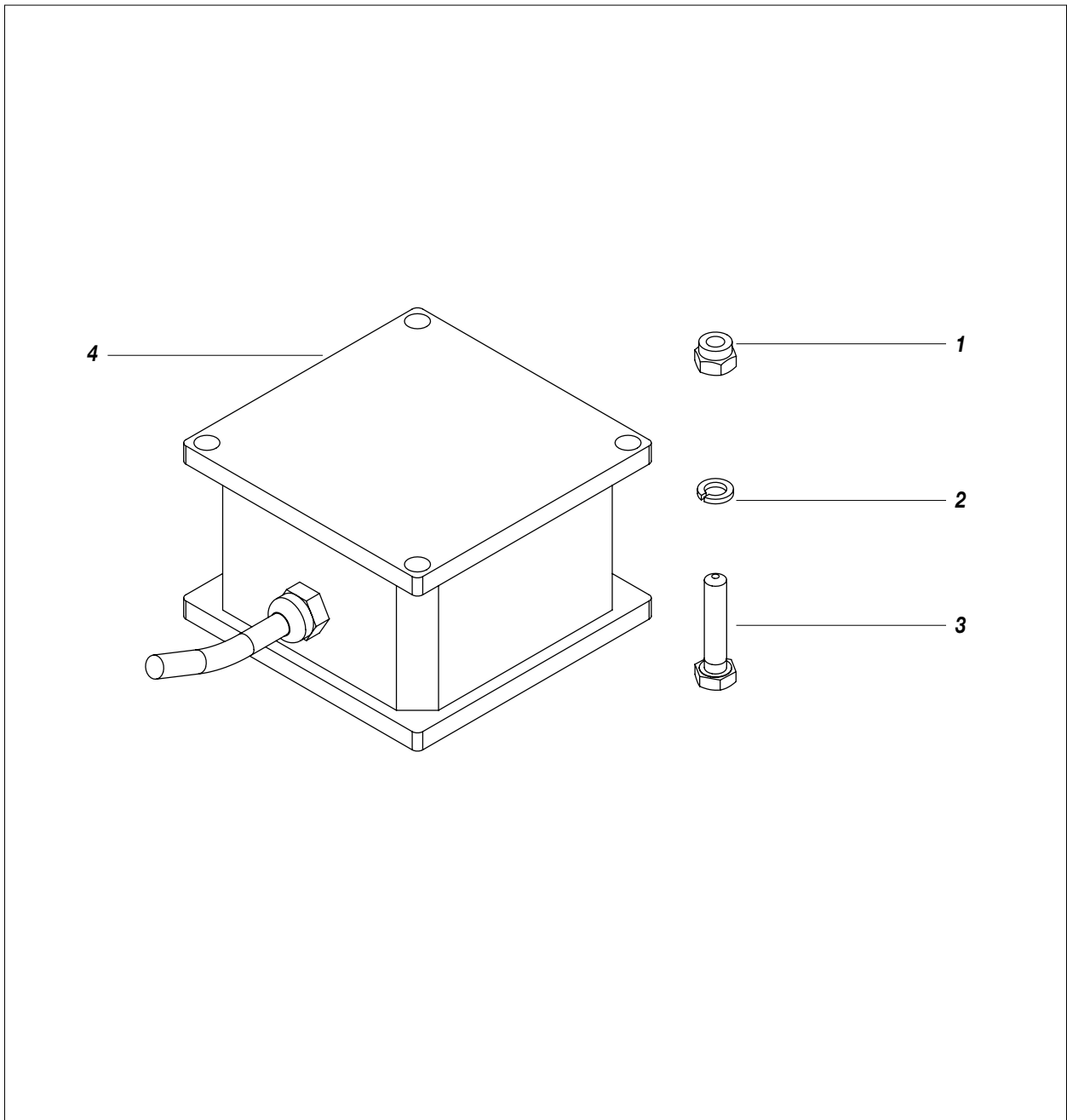

Pos.	Code	Description
-	LA4845	Complete box transformer
1	LA8042	Nut
2	LA32005	Washer

Pos.	Code	Description
3	LA91062	Screw
4	LA4846	Transformer box

AD FLOW COMPENSATOR

WARNING: Always indicate code and quantity for each part required.

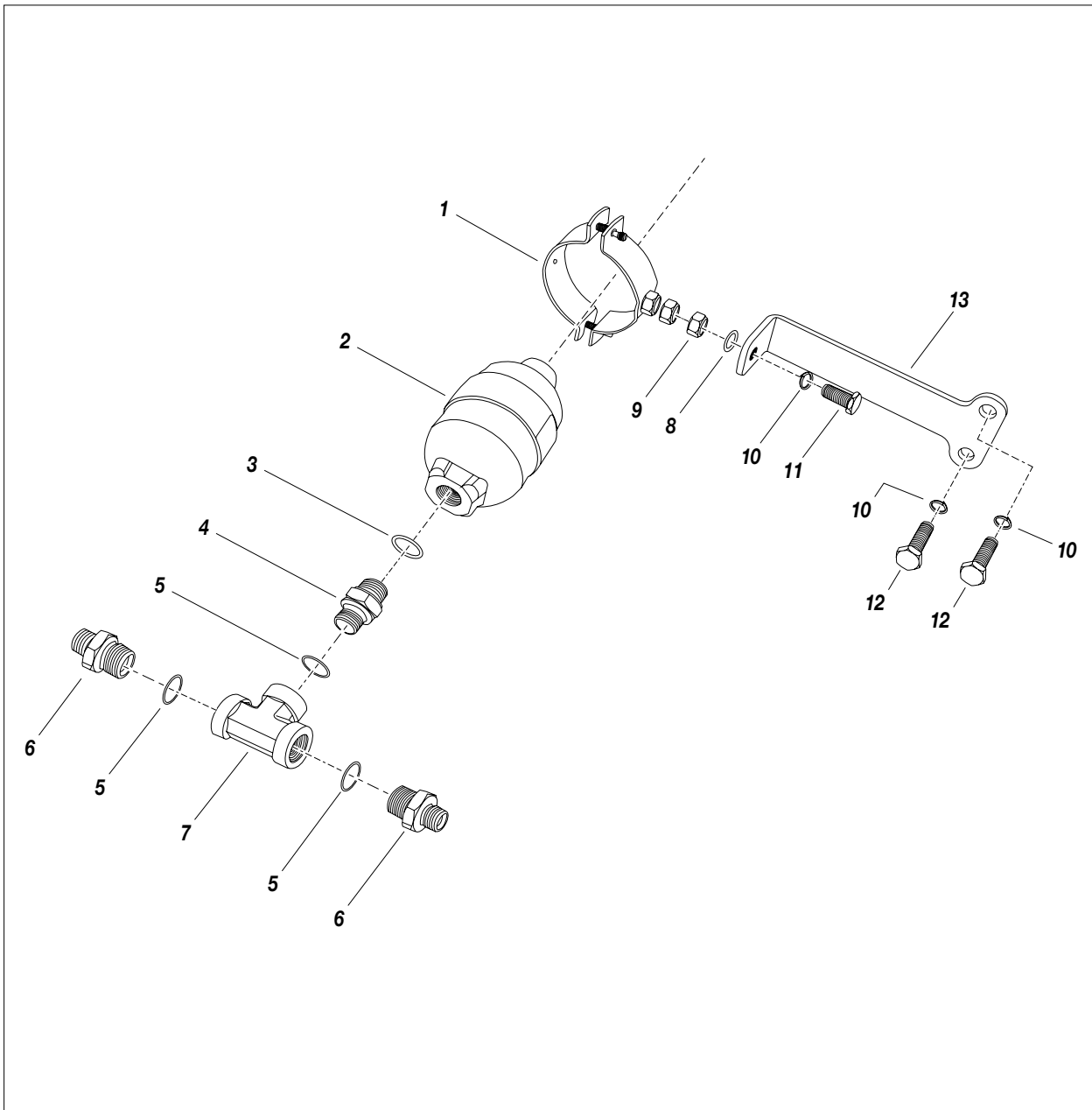

Pos.	Code	Description	Q. ty
1	LA4522	Collar	1
2	LA3372	Flow compensator	1
3	LA37180	Gasket	1
4	LA3283	Union	1
5	LA33010	Gasket	3
6	LA22022	Union	2
7	LA8078/1	T fitting	1

Pos.	Code	Description	Q. ty
8	LA81033	Washer	1
9	LA96080	Nut	1
10	LA95096	Washer (Typ Grower)	3
11	LA4407	Screw	1
12	LA20560	Screw	2
13	LA4847	Bracket	1

AE RE-CIRCULATION UNIT COMPLETE WITH COVER REF. LA4893

WARNING: Always indicate code and quantity for each part required.

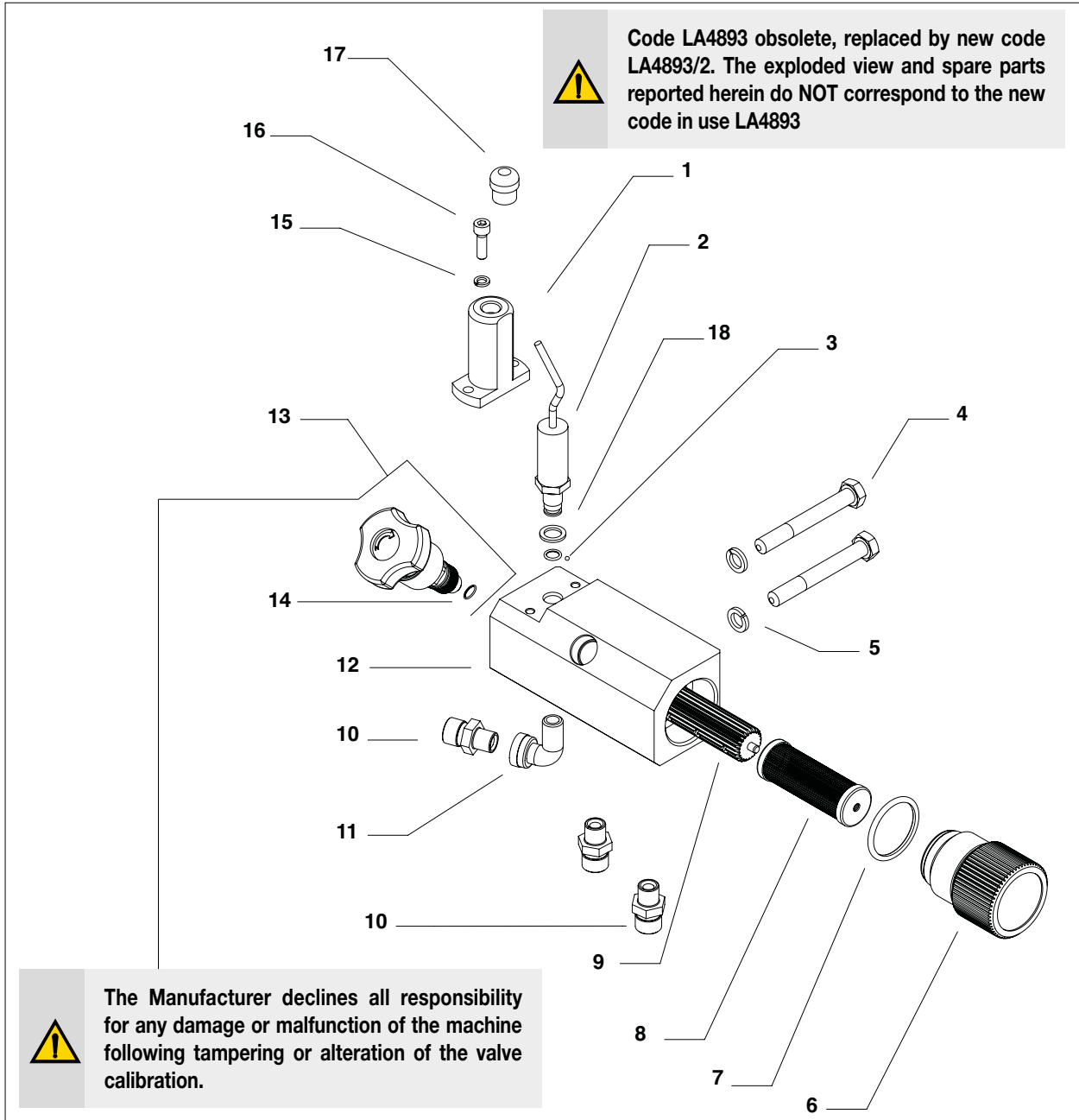

Pos.	Code	Description
-	LA4893	Re-circulation unit complete with cover
1	LA4891	Cover
2	LA18692	Sensor
3	LA18689	Tenuta Or
4	LA33004	Screw
5	LA33005	Washer
6	LA18580	Plug
7	LA18622	Or Seal
8	LA16205	Filter
9	LA18627	Sieve

Pos.	Code	Description
10	LA96206	Union
11	LA18614	Union
12	LA4892	Base
13	LA56563	Valve
14	LA4033	O-Ring
15	LA32005	Washer
16	LA91062	Screw
17	LA18871	Cable fastener
18	LA18684	Copper gasket

Intentionally blank page



CE DECLARATION OF CONFORMITY



Company



LARIUS srl
Via Antonio Stoppani 21 - 23801 Calolziocorte (LC) ITALY
Tel: +39 0341 621152
Fax: +39 0341 621243
E-mail: larius@larius.com

Declares under his owns responsibility that the product:

EXCALIBUR LINER **Airless line marker with piston pump**

complies with the directives:

- EC Directive 2006/42 Machinery Directive
- EU Directive 2014/30 Electromagnetic Compatibility (EMC)
- EU Directive 2014/35 Low Voltage (LVD)

furthermore to the
harmonized standards:

- UNI EN ISO 12100-1/-2
Machinery safety, basic concepts, general principles of design. Basic terminology, methodology. Technical principles.

This declaration relates exclusively to the product in the state in which it was placed on the market, and excludes components or modifications which are added or carried out subsequently by end user.

Signature

Pierangelo Castagna
Managing Director

Calolziocorte, 15 March 2024
Location / Date



**SAMOA INDUSTRIAL, S.A. - HEADQUARTERS
SPAIN AND EXPORT MARKETS**

POL. IND. PORCEYO, I-14 - CAMINO DEL FONTÁN, 831
E-33392 GIJÓN (ASTURIAS), SPAIN
TEL.: +34 985 381 488 - FAX: + 34 985 147 213

**SAMOA ITALIA - LARIUS
ITALY**

VIA ANTONIO STOPPANI,21
23801 CALOLZIOCORTE (LC) ITALY
Tel.: +39 0341 621152 - Fax: + 39 0341 621242

**SAMOA LTD.
UNITED KINGDOM AND REP. OF IRELAND**

ASTURIAS HOUSE - BARRS FOLD ROAD
WINGATES INDUSTRIAL PARK
WESTHOUGHTON, BL5 3XP, UK
TEL.: +44 1942 850600 - FAX: +44 1942 812160

**SAMOA S.A.R.L.
FRANCE**

P.A.E.I. DU GIESSEN
3, RUE DE BRISCHBACH
67750 SCHERWILLER, FRANCE
TEL.: +33 3 88 82 79 62 - FAX: +33 3 88 82 77 88

SAMOA FLOWTECH GMBH

GERMANY, AUSTRIA, SWITZERLAND, THE NETHERLANDS AND GREECE
AM OBEREICHHOLZ 4
D - 97828 MARKTHEIDENFELD, GERMANY
TEL.: +49 9391 9826 0 - FAX: +49 9391 98 26 50

SAMOA CORPORATION







USA AND CANADA
90 MONTICELLO ROAD
WEAVERVILLE, NC 28787, USA
TEL. +1 (828) 645-2290 - FAX: +1 (828) 658 0840



©Copyright, SAMOA INDUSTRIAL, S.A.
SAMOA Industrial, S.A. is an ISO 9001, ISO 14001 and ISO 45001 certified company.

»» Contact us today!

Visit www.samoaindustrial.com for more information.

OPERATING AND MAINTAINANCE MANUAL AVAILABLE IN:		
	IT	https://www.larius.com/wp-content/uploads/EXCALIBUR_LINER_I.pdf
	EN	https://www.larius.com/wp-content/uploads/EXCALIBUR_LINER_GB.pdf
	DE	https://www.larius.com/wp-content/uploads/EXCALIBUR_LINER_D.pdf
	FR	https://www.larius.com/wp-content/uploads/EXCALIBUR_LINER_F.pdf
	ES	https://www.larius.com/wp-content/uploads/EXCALIBUR_LINER_SP.pdf
	PL	https://www.larius.com/wp-content/uploads/EXCALIBUR_LINER_PL.pdf