



[www.larius.com](http://www.larius.com)

# EVEREST TH LINER

Horizontal Street Marking



- [IT](https://www.larius.com/wp-content/uploads/EVERESTLINER_I.pdf) [https://www.larius.com/wp-content/uploads/EVERESTLINER\\_I.pdf](https://www.larius.com/wp-content/uploads/EVERESTLINER_I.pdf)
- [EN](https://www.larius.com/wp-content/uploads/EVERESTLINER_GB.pdf) [https://www.larius.com/wp-content/uploads/EVERESTLINER\\_GB.pdf](https://www.larius.com/wp-content/uploads/EVERESTLINER_GB.pdf)
- [DE](https://www.larius.com/wp-content/uploads/EVERESTLINER_D.pdf) [https://www.larius.com/wp-content/uploads/EVERESTLINER\\_D.pdf](https://www.larius.com/wp-content/uploads/EVERESTLINER_D.pdf)
- [FR](https://www.larius.com/wp-content/uploads/EVERESTLINER_F.pdf) [https://www.larius.com/wp-content/uploads/EVERESTLINER\\_F.pdf](https://www.larius.com/wp-content/uploads/EVERESTLINER_F.pdf)
- [ES](https://www.larius.com/wp-content/uploads/EVERESTLINER_SP.pdf) [https://www.larius.com/wp-content/uploads/EVERESTLINER\\_SP.pdf](https://www.larius.com/wp-content/uploads/EVERESTLINER_SP.pdf)
- [PL](https://www.larius.com/wp-content/uploads/EVERESTLINER_PL.pdf) [https://www.larius.com/wp-content/uploads/EVERESTLINER\\_PL.pdf](https://www.larius.com/wp-content/uploads/EVERESTLINER_PL.pdf)



**This manual is to be considered as an English language translation of the original manual in Italian. The manufacturer shall bear no responsibility for any damages or inconveniences that may arise due to the incorrect translation of the instructions contained within the original manual in Italian.**

**Due to a constant product improvement programme, the factory reserves the right to modify technical details mentioned in this manual without prior notice.**

# EVEREST TH LINER

Self-propelled professional line-marker

## INDEX



















<b>A</b> WARNINGS .....	p.2	<b>V</b> REPLACEMENT OF THE PUMPING GROUP GASKETS .	p.38
<b>B</b> TRANSPORT AND UNPACKING.....	p.3	<b>W</b> PROBLEMS AND SOLUTIONS .....	p.46
<b>C</b> CONDITIONS OF GUARANTEE.....	p.3	SPARE PARTS .....	p.47
<b>D</b> SAFETY RULES .....	p.3	<b>X</b> PIVOTING FRONTAL WHEEL .....	p.48
<b>E</b> WORKING PRINCIPLE .....	p.4	<b>Y</b> PAINT CANISTER ASSEMBLY .....	p.50
<b>F</b> TECHNICAL DATA.....	p.5	<b>Z</b> SPEED POTENTIOMETER ASSEMBLY .....	p.52
<b>G</b> DESCRIPTION OF THE EQUIPMENT .....	p.9	<b>AA</b> HANDLEBAR CONTROLS .....	p.53
<b>H</b> DESCRIPTION OF THE CONTROLS .....	p.14	<b>AB</b> SOLENOID VALVE BOX.....	p.54
<b>I</b> USE OF THE EVEREST LINER CONTROL PANEL .....	p.18	<b>AC</b> OPERATOR FOOTBOARD .....	p.56
<b>J</b> LINE SEQUENCING FUNCTION .....	p.18	<b>AD</b> REVERSE BUZZER.....	p.57
<b>K</b> SPACE AND LINE SETTINGS .....	p.23	<b>AE</b> FILTER GROUP .....	p.68
<b>L</b> SETTING UP .....	p.25	<b>AF</b> COMPLETE SHORT PUMPING ELEMENT .....	p.60
<b>M</b> WORKING .....	p.28	<b>AG</b> REDUCTION UNIT .....	p.62
<b>N</b> PAINTING OPERATIONS .....	p.29	<b>AH</b> AT250 HIGH PRESSURE SPRAY GUN .....	p.64
<b>O</b> GLASS BEAD DISPENSER SYSTEM .....	p.31	<b>AI</b> LA95 SPRAY GUN EXPLODED VIEW .....	p.66
<b>P</b> SETTINGS.....	p.31	<b>AJ</b> FLOW COMPENSATOR .....	p.68
<b>Q</b> CLEANING AT THE END OF THE WORK.....	p.34	<b>AK</b> BATTERY GROUP.....	p.69
<b>R</b> GENERAL MAINTENANCE.....	p.35	<b>AL</b> BOARD V.2.50.....	p.69
<b>S</b> ROUTINE MAINTENANCE.....	p.35	<b>AM</b> INFORMATION FOR THE CORRECT CHOICE OF THE AIRLESS ROAD SIGS PAINT TO USE.....	p.70
<b>T</b> CHARGING THE BATTERY .....	p.37	CE DECLARATION OF CONFORMITY.....	p.71
<b>U</b> CORRECT PROCEDURE OF DECOMPRESSION.....	p.38		

**WE ADVISE THE USE OF THIS EQUIPMENT ONLY BY PROFESSIONAL OPERATORS.  
ONLY USE THIS MACHINE FOR USAGE SPECIFICALLY MENTIONED IN THIS MANUAL.**

Thank you for choosing a **SAMOA** product.  
As well as the product purchased, you will receive a range of support services  
enabling you to achieve the results desired, quickly and professionally.

## A WARNINGS

The table below provides the meaning of the symbols used in this manual in relation to using, earthing, operating, maintaining, and repairing of this equipment.

	<ul style="list-style-type: none"> <li>• Read this operator's manual carefully before using the equipment.</li> <li>• An improper use of this machine can cause injuries to people or things.</li> <li>• Do not use this machine when under the influence of drugs or alcohol.</li> <li>• Do not modify the equipment under any circumstances.</li> <li>• Use products and solvents that are compatible with the various parts of the equipment, and read the manufacturer's warnings carefully.</li> <li>• See the Technical Details for the equipment given in the Manual.</li> <li>• Check the equipment for worn parts once a day. If any worn parts are found, replace them using <b>ONLY</b> original spare parts.</li> <li>• Keep children and animals away from work area.</li> <li>• Comply with all safety standards.</li> </ul>
	<ul style="list-style-type: none"> <li>• It indicates an accident risk or serious damage to equipment if this warning is not followed.</li> </ul>
   	<p><b>FIRE AND EXPLOSION HAZARD</b></p> <ul style="list-style-type: none"> <li>• Solvent and paint fumes in work area can ignite or explode.</li> <li>• <b>To help prevent fire and explosion:</b> <ul style="list-style-type: none"> <li>- Use equipment <b>ONLY</b> in well ventilated area.</li> <li>- Eliminate all ignition sources, such as pilot lights, cigarettes and plastic drop cloths (potential static arc).</li> <li>- Ground equipment and conductive objects.</li> <li>- Use only grounded hoses.</li> <li>- Do not use trichloroethane, methylene chloride, other halogenated hydrocarbon solvents or fluids containing such solvents in pressurized aluminium equipment. Such use can cause serious chemical reaction and equipment rupture, and result in death, serious injury, and property damage.</li> <li>- Do not form connections or switch light switches on or off if the air contains inflammable fumes.</li> </ul> </li> <li>• If electrical shocks or discharges are encountered the operation being carried out using the equipment <b>must be stopped immediately</b>.</li> <li>• Keep a fire extinguisher at hand in the immediate vicinity of the work area.</li> </ul>
	<ul style="list-style-type: none"> <li>• It indicates wound and finger squashing risk due to movable parts in the equipment.</li> <li>• Keep away from moving parts.</li> <li>• Do not use the equipment without the proper protection.</li> <li>• Before any inspection or maintenance of the equipment, carry out the decompression procedure explained in this manual, and prevent any risk of the equipment starting unexpectedly.</li> </ul>
 	<ul style="list-style-type: none"> <li>• Report any risk of chemical reaction or explosion if this warning has not been given.</li> <li>• (IF PROVIDED) There is a risk of injury or serious lesion related to contact with the jet from the spray gun. If this should occur, <b>IMMEDIATELY</b> contact a doctor, indicating the type of product injected.</li> <li>• (IF PROVIDED) Do not spray before the guard has been placed over the nozzle and the trigger on the spray gun.</li> <li>• (IF PROVIDED) Do not put your fingers in the spray gun nozzle.</li> <li>• Once work has been completed, before carrying out any maintenance, complete the decompression procedure.</li> </ul>
	<ul style="list-style-type: none"> <li>• It indicates important recommendations about disposal and recycling process of products in accordance with the environmental regulations.</li> </ul>
    	<ul style="list-style-type: none"> <li>• Mark any clamps attached to earth cables.</li> <li>• Use <b>ONLY</b> 3-wire extension cords and grounded electrical outlets.</li> <li>• Before starting work make sure that the electrical system is grounded and that it complies with safety standards.</li> <li>• High-pressure fluid from gun, hose leaks, or ruptured components will pierce skin.</li> <li>• <b>To help prevent injection, always:</b> <ul style="list-style-type: none"> <li>- (IF PROVIDED) Engage trigger lock when not spraying.</li> <li>- (IF PROVIDED) Do not put your hand over the spray tip. Do not stop or deflect leaks with your hand, body or other.</li> <li>- (IF PROVIDED) Do not point gun at anyone or at any part of the body.</li> <li>- (IF PROVIDED) Never spray without tip guard.</li> <li>- Do pressure relief if you stop spraying or being servicing sprayer and before any maintenance operations.</li> <li>- Do not use components rated less than sprayer Maximum Working Pressure.</li> <li>- Never allow children to use this unit</li> <li>- (IF PROVIDED) Brace yourself; gun may recoil when triggered.</li> </ul> </li> <li>• <b>If high pressure fluid pierces your skin, the injury might look like "just a cut", but it is a serious wound! Get immediate medical attention.</b></li> </ul>
   	<ul style="list-style-type: none"> <li>• It is obligatory to wear suitable clothing as gloves, goggles and face shield.</li> <li>• Wear clothing that complies with the safety standards in force in the country in which the equipment is used.</li> <li>• Do not wear bracelets, earrings, rings, chains, or anything else that may hinder the operator's work.</li> <li>• Do not wear clothing with wide sleeves, scarves, ties, or any other piece of clothing that could get tangled up in moving parts of the equipment during the work, inspection, or maintenance cycles.</li> </ul>

## B TRANSPORT AND UNPACKING

- The packed parts should be handled as indicated in the symbols and markings on the outside of the packing.
- Before installing the equipment, ensure that the area to be used is large enough for such purposes, is properly lit and has a clean, smooth floor surface.
- The user is responsible for the operations of unloading and handling and should use the maximum care so as not to damage the individual parts or injure anyone.

To perform the unloading operation, use only qualified and trained personnel (truck and crane operators, etc.) and also suitable hoisting equipment for the weight of the installation or its parts.

Follow carefully all the safety rules.

The personnel must be equipped with the necessary safety clothing.

- The manufacturer will not be responsible for the unloading operations and transport to the workplace of the machine.
- Check the packing is undamaged on receipt of the equipment. Unpack the machine and verify if there has been any damage due to transportation.

In case of damage, call immediately LARIUS and the Shipping Agent. All the notices about possible damage or anomalies must arrive timely within 8 days at least from the date of receipt of the plant through Registered Letter to the Shipping Agent and to LARIUS.



**The disposal of packaging materials is a customer's competence and must be performed in accordance with the regulations in force in the country where the plant is installed and used. It is nevertheless sound practice to recycle packaging materials in an environment-friendly manner as much as possible.**

## C CONDITIONS OF GUARANTEE



**The conditions of guarantee do not apply in the following situations:**

- improper washing and cleaning of components causing malfunction, wear or damage to the equipment or any of its parts;
- improper use of the equipment;
- use that does not conform with applicable national legislation;
- incorrect or faulty installation;
- modifications, interventions and maintenance that have not been authorised by the manufacturer;
- use of non-original spare parts or parts that do not correspond to the specific model;
- total or partial non-compliance with the instructions provided.

## D SAFETY RULES



**Read carefully and entirely the following instructions before using the product. Please save these instructions in a safe place.**



**The unauthorised tampering/replacement of one or more parts composing the machine, the use of accessories, tools, expendable materials other than those recommended by the manufacturer can be a danger of accident.**



**The manufacturer will be relieved from tort and criminal liability.**

- THE EMPLOYER SHALL TRAIN ITS EMPLOYEES ABOUT ALL THOSE RISKS STEMMING FROM ACCIDENTS, ABOUT THE USE OF SAFETY DEVICES FOR THEIR OWN SAFETY AND ABOUT THE GENERAL RULES FOR ACCIDENT PREVENTION IN COMPLIANCE WITH INTERNATIONAL REGULATIONS AND WITH THE LAWS OF THE COUNTRY WHERE THE PLANT IS USED.
- THE BEHAVIOUR OF THE EMPLOYEES SHALL STRICTLY COMPLY WITH THE ACCIDENT PREVENTION AND ALSO ENVIRONMENTAL REGULATIONS IN FORCE IN THE COUNTRY WHERE THE PLANT IS INSTALLED AND USED.
- KEEP YOUR WORK PLACE CLEAN AND TIDY. DISORDER WHERE YOU ARE WORKING CREATES A POTENTIAL RISK OF ACCIDENTS.
- ALWAYS KEEP PROPER BALANCE AVOIDING UNUSUAL STANCE.
- BEFORE USING THE TOOL, ENSURE THERE ARE NOT DAMAGED PARTS AND THE MACHINE CAN WORK PROPERLY.
- ALWAYS FOLLOW THE INSTRUCTIONS ABOUT SAFETY AND THE REGULATIONS IN FORCE.
- KEEP THOSE WHO ARE NOT RESPONSIBLE FOR THE EQUIPMENT OUT OF THE WORK AREA.
- NEVER EXCEED THE MAXIMUM WORKING PRESSURE INDICATED.
- (IF PROVIDED) NEVER POINT THE SPRAY GUN AT YOURSELVES OR AT OTHER PEOPLE. THE CONTACT WITH THE CASTING CAN CAUSE SERIOUS INJURIES.
- IN CASE OF INJURIES CAUSED BY THE GUN CASTING, SEEK IMMEDIATE MEDICAL ADVICE SPECIFYING THE TYPE OF THE PRODUCT INJECTED. NEVER UNDERVALUE A WOUND CAUSED BY THE INJECTION OF A FLUID.
- ALWAYS DISCONNECT THE SUPPLY AND RELEASE THE PRESSURE IN THE CIRCUIT BEFORE PERFORMING ANY CHECK OR PART REPLACEMENT OF THE EQUIPMENT.
- NEVER MODIFY ANY PART IN THE EQUIPMENT. CHECK REGULARLY THE COMPONENTS OF THE SYSTEM.  
REPLACE THE PARTS DAMAGED OR WORN.
- (IF PROVIDED) TIGHTEN AND CHECK ALL THE FITTINGS FOR CONNECTION BETWEEN PUMP, FLEXIBLE HOSE AND SPRAY GUN BEFORE USING THE EQUIPMENT.

- ALWAYS USE THE FLEXIBLE HOSE SUPPLIED WITH STANDARD KIT.
- THE USE OF ANY ACCESSORIES OR TOOLING OTHER THAN THOSE RECOMMENDED IN THIS MANUAL, MAY CAUSE DAMAGE OR INJURE THE OPERATOR.
- THE FLUID CONTAINED IN THE FLEXIBLE HOSE CAN BE VERY DANGEROUS. HANDLE THE FLEXIBLE HOSE CAREFULLY. DO NOT PULL THE FLEXIBLE HOSE TO MOVE THE EQUIPMENT. NEVER USE A DAMAGED OR A REPAIRED FLEXIBLE HOSE.



The high speed of travel of the product in the hose can create static electricity through discharges and sparks. It is suggested to earth the equipment. The pump is earthed through the earth cable of the supply.



The gun is earthed through the high pressure flexible hose. All the conductors near the work area must be earthed.

Never spray over flammable products or solvents in closed places.

Never use the tooling in presence of potentially explosive gas.



Always check that the product is compatible with the materials composing the equipment (pump, spray gun, flexible hose and accessories) with which it can come into contact. Never use paints or solvents containing Halogen Hydrocarbons (as the Methylene Chloride). If these products come into contact with aluminium parts can provoke dangerous chemical reactions with risk of corrosion and explosion.



Avoid approaching too much to the pump piston rod when the pump is working or under pressure. A sudden movement of the piston rod can cause wounds or finger squashing.



If the product to be used is toxic, avoid inhalation and contact by using protection gloves, goggles and proper face shields.



Take proper safety measures for the protection of hearing in case of work near the plant.



## E WORKING PRINCIPLE

The **EVEREST TH LINER** is a self-propelled device which was conceived and designed for performing road markings along particularly difficult tracts of uneven road where marking would otherwise be difficult to complete.

The internal combustion engine, mounted upon the undercarriage, powers the alternative piston pump and the alternator which is utilised for charging the battery unit. The two-wheel frontal-traction is powered by an electric motor which allows for easy operator movement, even on medium-grade inclines.

The control zone allows for the possibility of:

- Activating the two dispensing spray guns;
- Enabling or disabling the frontal steering wheel;
- Increasing the motor's Rpm's;
- Enabling / disabling front-wheel traction;
- Gradually increasing the advancement speed of the self-propelled undercarriage;
- Opening / closing flow to the 2nd spray gun;
- Selecting solid or broken-line painting functionality.

This type of device is capable of marking two side-by-side lines of the same colour simultaneously.

The lines may be solid, broken or mixed.

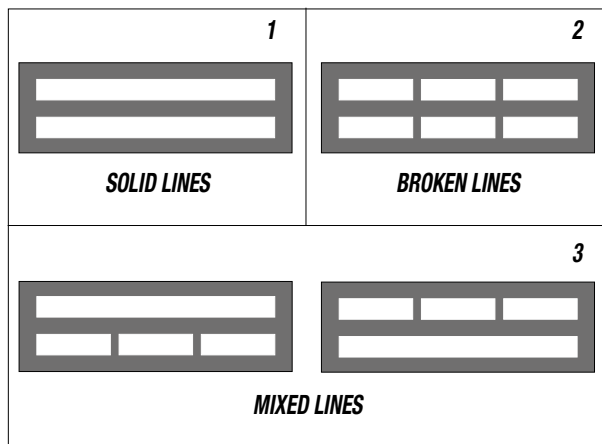

**EVEREST TH LINER** is perfect for large-scale lining and maintenance works.



Use water or non-refractive solvent filtered paint specifically designed for airless application.

**EVEREST TH LINER** allows for the marking and maintaining of all types lines on highways, freeways, pedestrian crossings, parking lots and squares, as well as every horizontal marking required by the highway code.

Airless marking has numerous proven benefits with respect to line-markers with pressurised tanks, which have been rendered obsolete by airless-technology line markers.

Airless line-marking guarantees:

- Decreased Environmental Impact;
- Decreased drying time.

The paint dries quickly and the line is defined in a uniform manner with a single coat. The airless function requires the use of filtered paint which is specifically designed for airless application. This means that the paint is homogeneous, of a smooth and uniform consistency and will not form crusts, nor will it become gelatinous or thick. With this airless line-marker, the paint adheres firmly to all types of pavement, with optimal visibility, and is resistance to wear caused both by traffic as well as atmospheric agents.

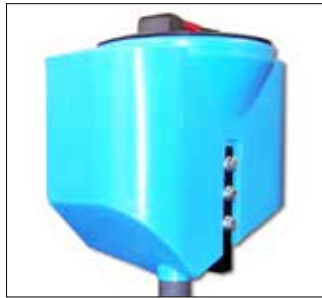

The refractive effect is obtained by the release of refractive spheres from an appropriate tank. These spheres automatically “fall” onto the painted line and, for this reason, pre-mixed or beaded paints do not have to be used. The device’s continued proper function is guaranteed through the exclusive use of suitable and quality paints. A high degree of workplace safety and cleanliness is achieved thanks to the help of the pressurised tanks.

In these models, the paint canister can be loaded directly upon the undercarriage or else poured into the non-stick, 50 L tank. In every case, cleaning, maintenance and colour change operations are facilitated.



The line-marker is equipped with a 360° pivoting frontal wheel which even increases the agility of the larger models. High yield, high efficiency, high versatility.



This line-marker utilises non-premixed paints. This allows it to achieve about 30% more yield with respect to standard line-markers. Every model is also an airless spray gun which can be used in the construction/decoration sector together with washable products, enamels, breathable paints and flooring resins.

A vast assortment of accessories is available to satisfy every customer demand.

## F TECHNICAL DATA

EVEREST LINER	
Motor power	11,7 - HP
Max. Delivery	9 - l/m
Max. pressure	220 bar
Guns	n°1 manul AT250 - n°2 automatic LA96
Power supply	24 V
Sizes of the furnished nozzles	2 x 13-40 - 2 x 17-40 - 2 x 21-40 - 1 x 19-40
50 L tank	series (100 l on request)
Colours	w1
Automatic line-marking	series
Applications	Excellent road-marking and maintenance
Weight	350 kg
Lenght	(A) 1920 mm
Height	(B) 1450 mm
Width	(C) 1580 mm

**EVEREST TH series RIF. LA4000**

STANDARD EQUIPMENT			
N°1	Ø 1/4" - M16X1,5 inlet swivel- 15 m Airless hose	N°1	Super fast clean airless nozzle 19-40
N°1	Filter with pressure gauge	N°1	Flashing telescoping rod
N°1	Recirculation hose	N°1	Head Control advanced marking system
N°1	50 l gravity tank	N°1	Glass beads dispenser kit
N°1	AT250 manual airless gun	N°1	Piston accumulator
N°2	LA96 automatic airless gun	N°1	Working light
N°3	airless nozzle holder LA11708	N°1	footboard operator
N°2	Super fast clean airless nozzle 13-40	N°1	Gun handling + front pivot
N°2	Super fast clean airless nozzle 17-40	N°1	Tools box
N°2	Super fast clean airless nozzle 21-40		

ACCESSORIES	
<b>RIF. LA18206</b>	Ø 1/4" - M16X1,5 inlet swivel- 15 m Airless hose
<b>RIF. LA11200</b>	AT250 manual airless gun - M16 x 1,5 inlet swivel + Nozzle holder
<b>RIF. LA11210</b>	AT250 manual airless gun - M16 x 1,5 inlet swivel
<b>RIF. LA11701</b>	LA96 automatic airless gun - M16 X1,5 inlet swivel + Nozzle holder
<b>RIF. LA11708</b>	LA96 automatic airless gun - M16 X1,5 inlet swive
<b>RIF. LA18270</b>	11/16" W Europe W airless nozzle holder
<b>RIF. LASFC</b>	Super Fast Clean airless nozzle. Size 11-20 to 51-80
<b>RIF. LATSC</b>	Top Spraying Clean airless nozzle. Size 7-10 to 31-60
<b>RIF. LA18240</b>	50 l gravity tank
<b>RIF. LA18245</b>	50 l gravity tank + Cover
<b>RIF. LA18241</b>	50 l gravity tank + Cover+ basket
<b>RIF. LA 4500</b>	11 l gravity tank + glass beads diffuser hose
<b>RIF. LA26000</b>	footboard operator
<b>RIF. LA4720</b>	Seat Kit
<b>RIF. LA4756</b>	Piston accumulator
<b>RIF. LA19510</b>	11 l gravity tank for glass beads
<b>RIF. LA19510/1</b>	cover for 11 l gravity tank

KIT	
<b>RIF. LA4307</b>	Mounting Kit for second gun (airless gun not included)
<b>RIF. LA18359</b>	11 l Gravity tank + 1 Diffuser Hose + 1 Glass beads manual spray gun kit
<b>RIF. LA18359/2</b>	11 l Gravity tank + 2 Diffuser Hoses + 2 Glass beads manual spray guns kit
<b>RIF. LA4405/3</b>	11 l Gravity tank + 2 Diffuser Hoses + 2 Glass beads automatic spray guns kit
<b>RIF. LA4038</b>	Laser pointer Kit
<b>RIF. LA4506</b>	Working light Kit
<b>RIF. LA4507</b>	Flashing telescopic rod Kit
<b>RIF. LA4839</b>	Pneumatic gun handling + Front pivot wheel

**SFC SPRAY TIPS/NOZZLES TABLE - TSC**

Ø nozzle (inch)	Spray angle (°)	Line Width		Flow rate (gpm)	Flow rate (lpm)
		inch	mm		
.013	13 - 20	2 - 4	51 - 102	.18	.69
.015	15 - 20	2 - 4	51 - 102	.24	.91
	15 - 30	4 - 6	102 - 152		
.017	17 - 20	2 - 4	51 - 102	.31	1.17
	17 - 30	4 - 6	102 - 152		
	17 - 40	4 - 8	102 - 204		
.019	19 - 20	2 - 4	51 - 102	.38	1.47
	19 - 30	4 - 6	102 - 152		
	19 - 40	4 - 8	102 - 204		
.021	21 - 30	4 - 6	102 - 152	.47	1.79
	21 - 40	4 - 8	102 - 204		
	21 - 60	8 - 12	204 - 305		
.023	23 - 30	4 - 6	102 - 152	.57	2.15
	23 - 40	4 - 8	102 - 204		
	23 - 60	8 - 12	204 - 305		
.025	25 - 30	4 - 6	102 - 152	.67	2.54
	25 - 40	4 - 8	102 - 204		
	25 - 60	8 - 12	204 - 305		
.027	27 - 30	4 - 6	102 - 152	.77	2.96
	27 - 40	4 - 8	102 - 204		
	27 - 60	8 - 12	204 - 305		

Ø nozzle (inch)	Spray angle (°)	Line Width		Flow rate (gpm)	Flow rate (lpm)
		inch	mm		
.029	29 - 30	4 - 6	102 - 152	.90	3.42
	29 - 40	4 - 8	102 - 204		
	29 - 60	8 - 12	204 - 305		
.031	31 - 30	4 - 6	102 - 152	1.03	3.90
	31 - 40	4 - 8	102 - 204		
	31 - 60	8 - 12	204 - 305		
.033	33 - 30	4 - 6	102 - 152	1.17	4.42
.035	35 - 30	4 - 6	102 - 152	1.31	4.98
	35 - 40	4 - 8	102 - 204		
	35 - 60	8 - 12	204 - 305		
.039	39 - 30	4 - 6	102 - 152	1.63	6.18
	39 - 40	4 - 8	102 - 204		
	39 - 60	8 - 12	204 - 305		
.043	43 - 30	4 - 6	102 - 152	1.98	7.51
	43 - 40	4 - 8	102 - 204		
	43 - 60	8 - 12	204 - 305		

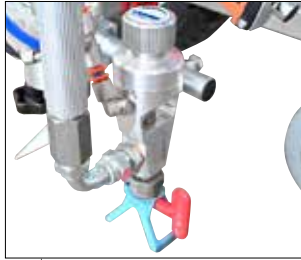

**LA95 airless spray gun**  
 For lines from 3 to 30 cm wide, mounted on an adjustable block: modify the spray pattern by altering the height of the gun or nozzle.



**Head Liner Control**  
 Easy and functional with: Automatic marking sequencer, electronic speed control and built-in safety



**400 mm Ø pneumatic wheels** guarantee stability and ease of movement as well as reduce the unevenness of the road's surface.

Fig. 1

**APPLICATIONS**

**BIG SIZE MARKING - MAINTENANCE PAINTING JOBS**

- Roads - Highways
- Galleries - Road tunnels
- Cycle runway
- Outdoor and underground parking
- Spot circuits
- Public and private areas
- Airports

**MATERIALS**

**WATER OR SOLVENT PAINT WITHOUT SUSPENDED PARTICLES**

**LINE TYPE**

**DOUBLE TYPE**

- 1 Colour
- Continuous - Dashed - Mixed
- Width from 5 to 30 cm



Continuous Line



Dashed Lines



Mixed Lines

## G DESCRIPTION OF THE EQUIPMENT



Pos.	Description
1	Internal combustion engine
2	Stablizer lifting cylinder
3	Laser pointer
4	LA95 airless spray-guns

Pos.	Description
5	Super fast clean nozzle
6	Gun holding arm
7	Kick Start
8	High pressure hose

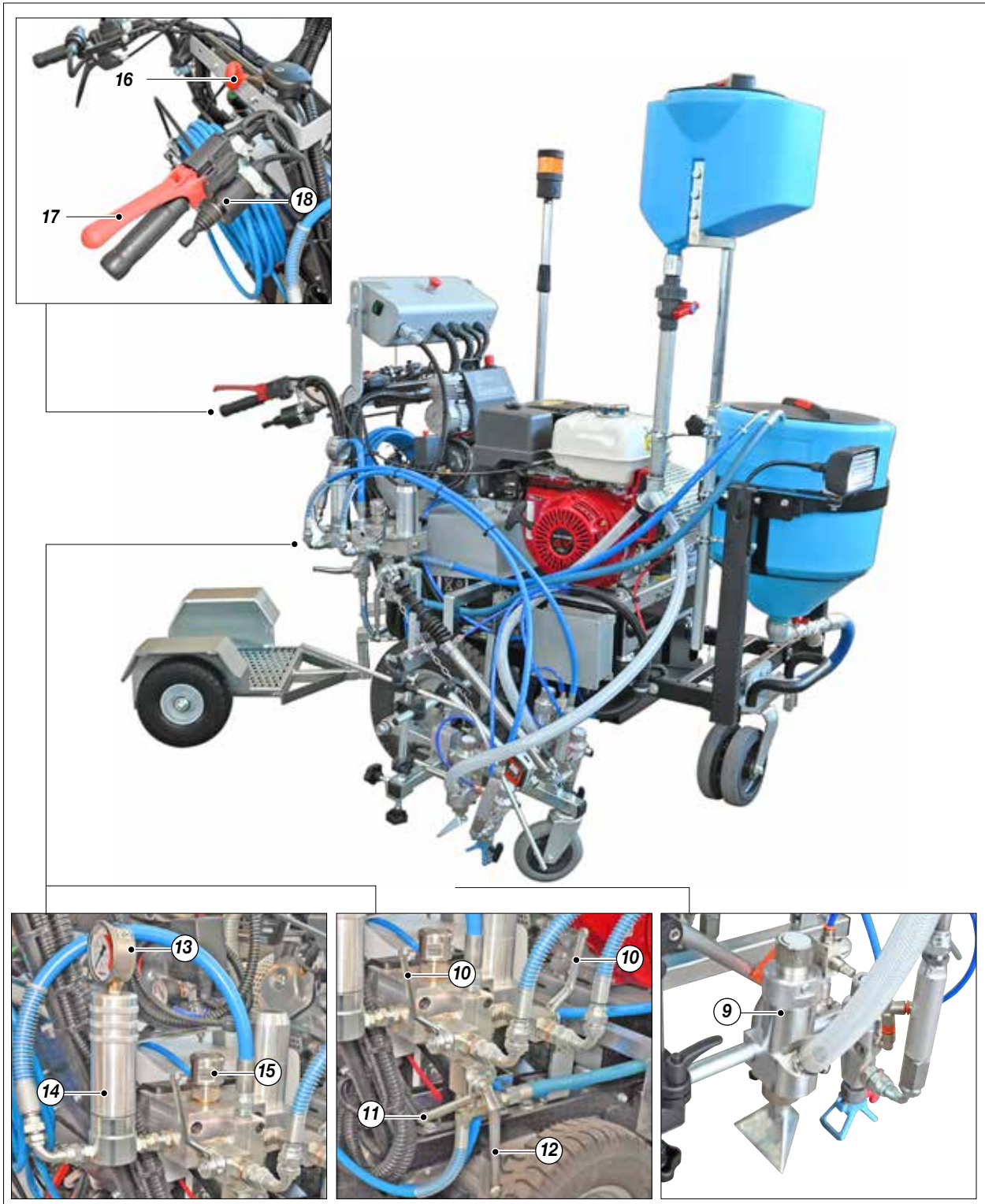

Pos.	Description
9	Pearls distributor gun
10	LA95 airless spray-gun valves
11	AT250 airless manual gun valve
12	Recirculation valve
13	Manometer

Pos.	Description
14	Intake filter
15	Safety valve
16	Motor acceleration lever
17	Machine driving lever
18	Control lever

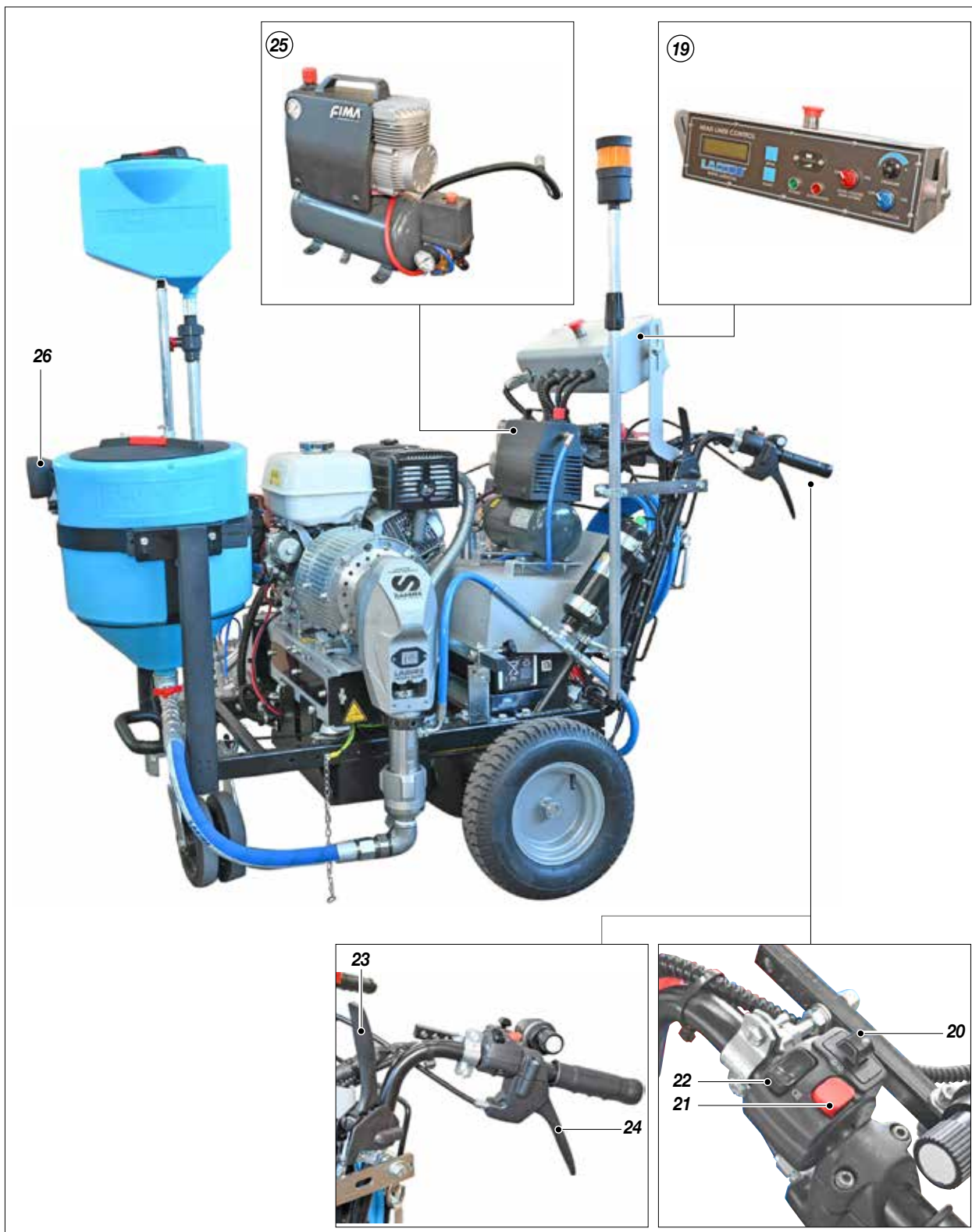

Pos.	Description
19	Liner control panel
20	Forward and backward selector
21	Manual spraying control switch
22	Light switch

Pos.	Description
23	Direction locking/releasing lever
24	Brake releasing lever
25	Pneumatic system supply compressor
26	Frontal light

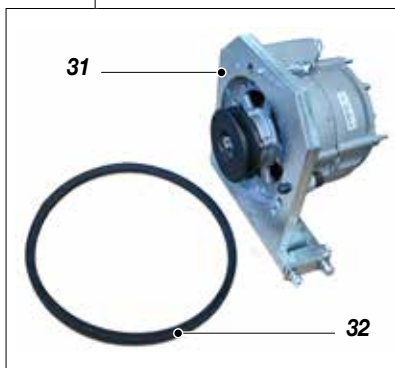
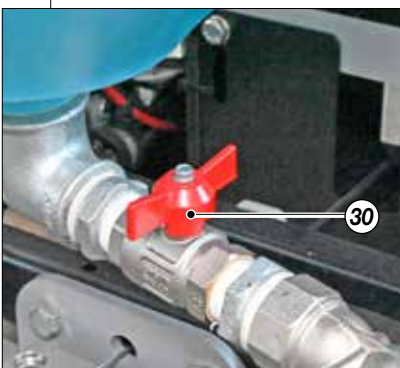
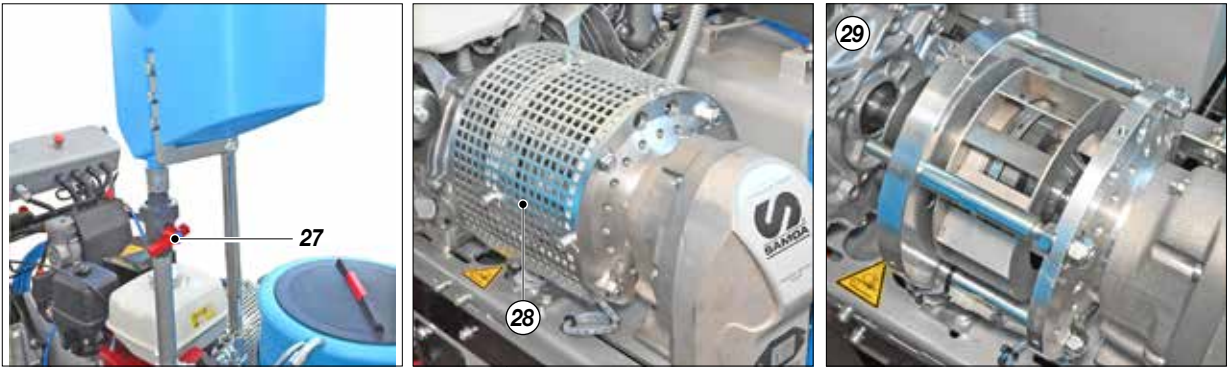

Pos.	Description
27	Bead feeding valve
28	Clutch guard
29	Clutch cooling fan
30	Paint valve

Pos.	Description
31	Battery charging alternator
32	Alternator belt
33	Traction motor (Forward - Reverse)



Pos.	Description
34	Flashing light
35	Flow compensator
36	Operator footboard

Pos.	Description
37	Frontal steering unit
38	Tank 50lt
39	Glass bead tank

# H DESCRIPTION OF THE CONTROLS

## LINER CONTROL PANEL

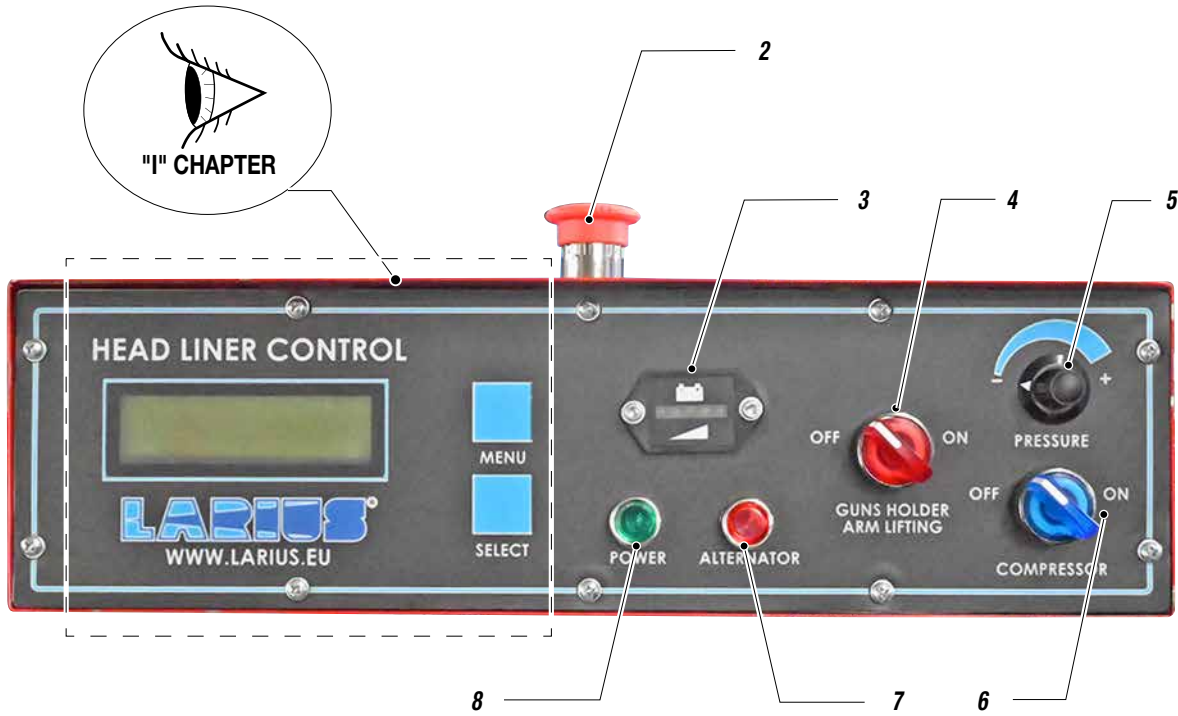
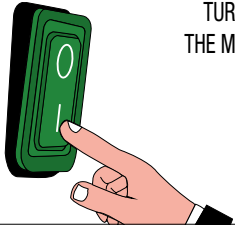

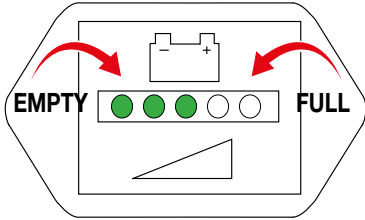
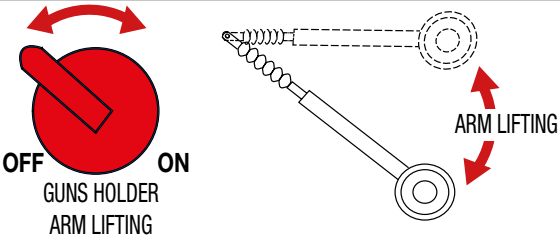
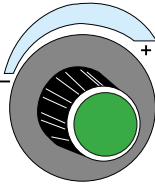
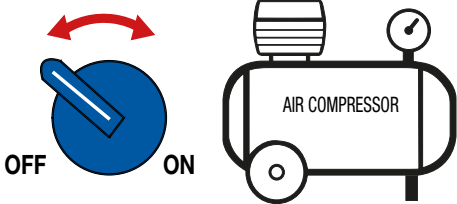
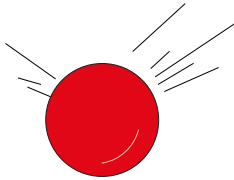
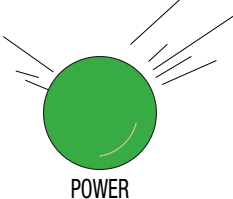

Fig. 1

Pos.	Description
1	<p><b>STARTING BUTTON</b> If pressed, it allows the machine to start</p>  <p>TURN ON THE MACHINE</p>
2	<p><b>EMERGENCY BUTTON</b> If pressed, it stops the machine immediately.</p> <p>PRESS TO STOP</p> 
3	<p><b>BATTERY LEVEL INDICATOR</b> Displays the battery charge status.</p> 
4	<p><b>RED LUMINOUS SELECTOR</b> Lifts or lowers the spray unit's stabilizing wheel.</p>  <p>OFF ON GUNS HOLDER ARM LIFTING</p>
5	<p><b>PRESSURE REGULATION HANDLE</b> Allows the user to gradually regulate the pressure.</p>  <p>PUMP PRESSURE</p>
6	<p><b>BLUE LUMINOUS SELECTOR</b> Activates the pneumatic circuit's compressor.</p>  <p>OFF ON AIR COMPRESSOR</p>
7	<p><b>ALTERNATOR</b> When the red indicator is on, it indicates a malfunction in the alternator required for charging the batteries.</p>  <p>ALARM ALTERNATOR</p>
8	<p><b>INDICATOR LIGHT</b> When on, indicates that the machine is ready for operation.</p>  <p>MACHINE ON POWER</p>

**GUN CONTROLS**

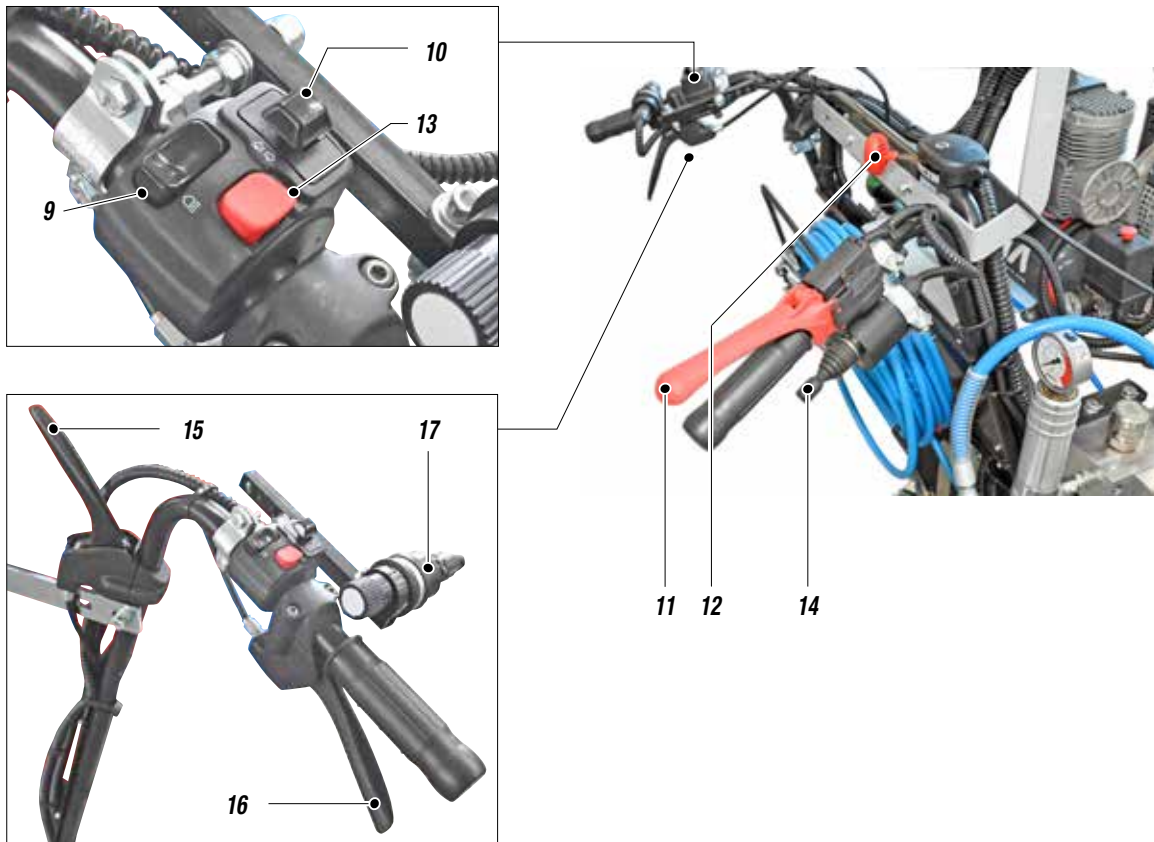
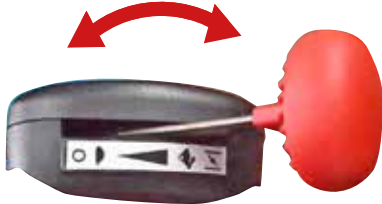
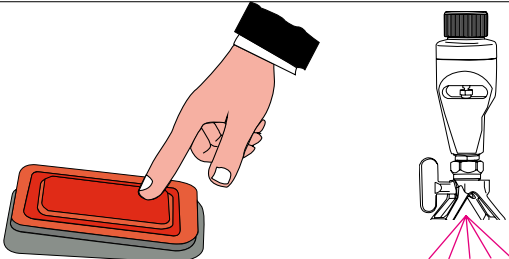

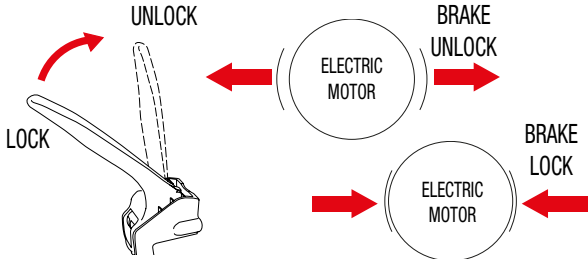
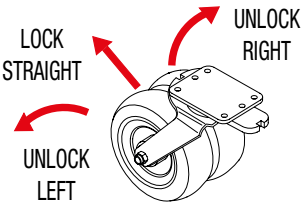



Fig. 2

Pos.	Description
9	<p><b>LIGHT SWITCH</b> Activates/deactivates the frontal spotlight (if installed).</p>
10	<p><b>DIRECTION SELECTOR</b> Allows the user to select the machine's advancement direction; Central position stops the machine's movement</p>
11	<p><b>ADVANCEMENT</b> If pressed, it allows the forward / backward movement of the machine</p>

Pos.	Description
12	<p><b>ACCELERATOR</b> It gradually sets the number of revolutions of the internal combustion engine.</p> 
13	<p><b>SPRAYING</b> By pressing it, the manual spraying is enabled.</p> 
14	<p><b>GUN CONTROL SELECTION LEVER</b> It allows to select automatic or manual mode of the guns</p> 
15	<p><b>TRACTION MOTOR ENGAGEMENT LEVER</b> When pressed, allows for the machine to be pushed manually.</p> 
16	<p><b>DIRECTIONAL LEVER</b> Pull on the lever to release the linear drive lock and allow the machine to perform curved line tracts.</p> 
17	<p><b>SPEED REGULATION HANDLE</b> Allows the user to gradually regulate the machine's advancement speed.</p> 

## I USE OF THE EVEREST LINER CONTROL PANEL



Keep the pressure adjustment handle (1) at minimum in order to access the various Menus.



Display when the electronic box is switched on Fig.1

MENU key

SELECT key

- Activate by means of a special interrupter "0-1" on the right side of the control panel;
- On the display appear date, time and temperature (see Fig. 1);
- Pressing the menu key will scroll through the list of functions 1 through 9.



### MENU 1: SETUP DATE

Press the "MENU" key and the first setting "1. DATE" will appear. To change the date:

- Press the "SELECT" key to enter the page;
- Press "MENU" to change the numbers for the date;
- Press "SELECT" to move from day to month and to year;
- Press "SELECT" when in the year position to return to point "1. DATE".

Press "MENU" to go on to point 2.



### MENU 2: SETUP TIME

When "MENU" is pressed from point 1, the display reads "2. TIME".

To change the time:

- Press the "SELECT" key to enter the page;
- Press "MENU" to change the numbers for the date;
- Press "SELECT" to move from hour to minutes and seconds;
- Press "SELECT" when in the second position to return to point "2. TIME".

Press "MENU" to go on to point 3.

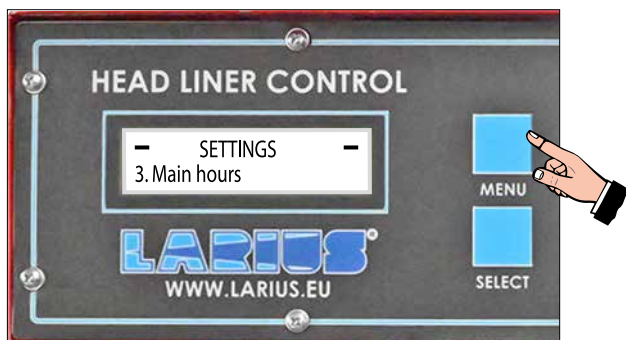

**MENU 3: SETTING MAINTENANCE HOURS**

When "MENU" is pressed from point 2, the display reads "3. MAINTENANCE HOURS". This menu is used to set the n° of hours between successive maintenance tasks.

To change the time:

- Press the "SELECT" key to enter the page;
- Press "MENU" to increase the time set. Hold "MENU" down and press and release "SELECT" to invert the counter and therefore reduce the time set. ;
- Press "SELECT" again to return to point "3. MAINTENANCE HOURS".

Press "MENU" to go on to point 4.



**MENU 4: MAINTENANCE ALERT**

When "MENU" is pressed from point 3, the display reads "4. MAINTENANCE ALERT". This menu is used to set the n° of hours prior warning for maintenance tasks.

To change:

- Press the "SELECT" key to enter the page;
- Press "MENU" to increase the time set. Hold "MENU" down and press and release "SELECT" to invert the counter and therefore reduce the time set;
- Press "SELECT" again to return to point "4. MAINTENANCE ALERT".

Press "MENU" to go on to point 5.



**MENU 5: MAINTENANCE DONE**

When "MENU" is pressed from point 4, the display reads "5. MAINTENANCE DONE". This menu is used to reset the countdown after having completed maintenance.

To change:

- Press the "SELECT" key to enter the page;
- Press "SELECT" again to confirm that maintenance has been done. The display automatically goes back to menu "5. MAINTENANCE DONE".

Press "MENU" to go on to point 6.



**MENU 6: TOTALS**

When "MENU" is pressed from point 5, the display reads "6. TOTALS". This menu shows the number of hours worked and the number of times the pump control clutch has been activated.

- Press the "MENU" or "SELECT" key to return to "6. TOTALS".
- Press "MENU" to go on to point 7.



Fig.1

**MENU 7: LANGUAGE**

When “MENU” is pressed from point 6, the display reads “7. LANGUAGE”. This menu can be used to set the language.

- Press the “SELECT” key to access the page, and the “MENU” key to switch from Italian to English and from English to Italian;
- Press “SELECT” to return to “7. LANGUAGE”. Press “MENU” to go on to point 8.

**MENU 8: SEQUENCER**

When “MENU” is pressed from point 7, the display reads “8. SEQUENCER”. This menu can be used to select or deselect the use of the automatic tracker.

- Press the “SELECT” key to access the page, and the “MENU” key to switch from sequencer YES or NO ;
- Press “SELECT” to return to “8. SEQUENCER”. Press “MENU” to go on to point 9.



**By choosing “sequencer yes” it is possible to access the line sequencing setting menu described further on.**

**MENU 9: RETURN**

When “MENU” is pressed from point 8, the display reads “9. RETURN”. This menu is used to go back to the initial page.

- Press the “SELECT” key to return to the initial page.

## J LINE SEQUENCING FUNCTION

From the initial page, if the “MENU” key is pressed twice, the “spray menu” mode is accessed spray menu (**N.B.** Only if Menu 8 was previously set to “Sequencer ON”).

**MENU 1: MANUAL COMMAND**

This function allows one to decide which gun to use with the control lever in the “continuous” position. The possibilities are:

- Gun SX only;
- Gun DX only;
- Guns SX and DX simultaneously;
- Press the menu button to change setting;
- Press the select key to exit.

**N.B.:** this menu refers only to the “MANUAL” (“MAN”).



**MENU 2: RIGHT LINE**

This function allows for the programming of the length of the *dashed* line.

- Press menu key until arriving at page 2;
- Press select key to enter the page;
- Press the menu key to increase the set value;
- Hold "MENU" down and press and release "SELECT" to invert the counter (*and therefore reduce the value set*).
- Press select to exit.



**MENU 3: RIGHT SPACE**

This function allows for the programming of the length of the blank area between *dashes*.

- Press menu key until arriving at page 3;
- Press select key to enter the page;
- Press the menu key to increase the set value;
- Hold "MENU" down and press and release "SELECT" to invert the counter (*and therefore reduce the value set*).
- Press select to exit.



**MENU 4: LEFT LINE**

This function allows for the programming of the length of the *dashed* line.

- Press menu key until arriving at page 4;
- Press select key to enter the page;
- Press the menu key to increase the set value;
- Hold "MENU" down and press and release "SELECT" to invert the counter (*and therefore reduce the value set*).
- Press select to exit.



**MENU 5: LEFT SPACE**

This function allows for the programming of the length of the blank area between *dashes*.

- Press menu key until arriving at page 5;
- Press select key to enter the page;
- Press the menu key to increase the set value;
- Hold "MENU" down and press and release "SELECT" to invert the counter (*and therefore reduce the value set*).
- Press select to exit.



**MENU 6: START LEFT SPACE**

This function allows for the spray delay to be set exclusively for the left gun.



### MENU 7: COMMAND

This function allows one to stabilize which guns will be used with the lever in the "AUTOMATIC" ("AUT") position.

- Press menu key until arriving at page 7;
- Press the select key to enter the page.

Possible settings are:

- Gun SX off + DX dashed;
- Gun SX off + DX continuous;
- Gun SX dashed + DX dashed;
- Gun SX dashed + DX continuous;
- Gun SX continuous + DX dashed
- Press the menu key to choose the desired setting;
- Press select to exit.



### MENU 8: STEP LENGTH

This function is used to correct any errors that may occur between the dotted line entered and the line actually made.

- Press the "MENU" key until page 9 is reached;
- Press the "SELECT" key to enter the page;
- Press the "MENU" key to increase the value set (*the line length is reduced*);
- Hold "MENU" down and press and release "SELECT" to invert the counter (*and therefore reduce the value set*). The length of the line increases;
- Press "SELECT" to exit.

N.B.: the step length is already set in the factory and generally does not need to be changed



### MENU 9: RETURN

This function is used to go back to the initial page.

- Press the "MENU" key until page 10 is reached;
- Press the "SELECT" key to return to the initial page.

Once the various options have been set, it is possible to change from a continuous line to a dotted line while the machine is running by simply changing the position of the control lever:

**AUT = AUTOMATIC** (works using the settings in menu "2. LINE" and "3. SPACE").

**MAN = MANUAL** (works using the settings in menu "1. MANUAL COMMAND").

## K SPACE AND LINE SETTINGS

- Possibility of programming the RH SPACE and RH LINE, LH SPACE and LH LINE independently.
- Introduced the DELAY SPRAYING LH gun parameter. The DELAY SPRAYING LH gun is only read by the programme once from when the spray control lever is enabled (AUT).



The SPACE and LINE measurement settings for the LH-RH guns have been taken to the second decimal resolution. Values of the following type can therefore be set: MT 1.54.

Example of programming to obtain the spray shown in "Figure 1"

RH line	2 MT
RH space	2 MT

LH line	1 MT
LH space	2 MT

LH delay spraying	0,5 MT
Control	LH=T RH=T

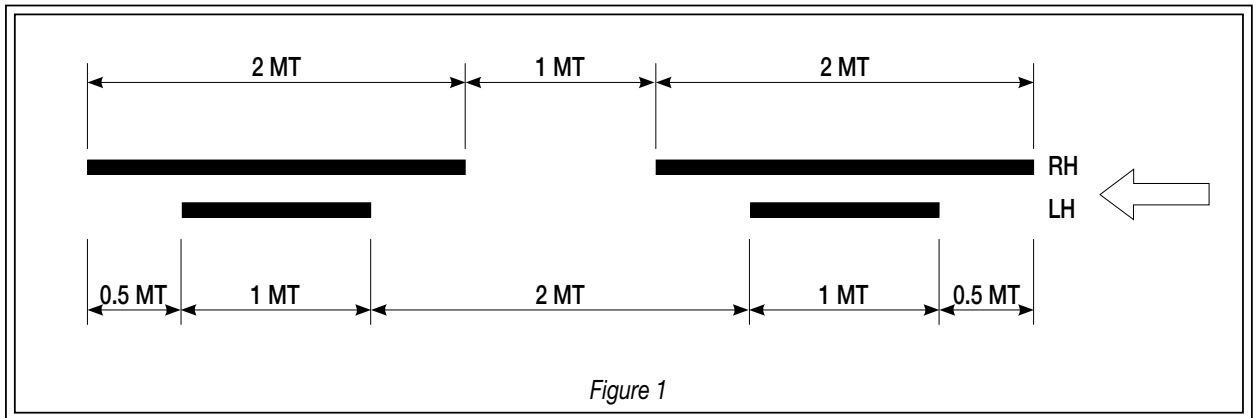

Example of programming to obtain the spray shown in "Figure 2"

RH line	2 MT
RH space	2 MT

LH line	0,4 MT
LH space	2,6 MT

LH delay spraying	0,3 MT
Control	LH=T RH=T

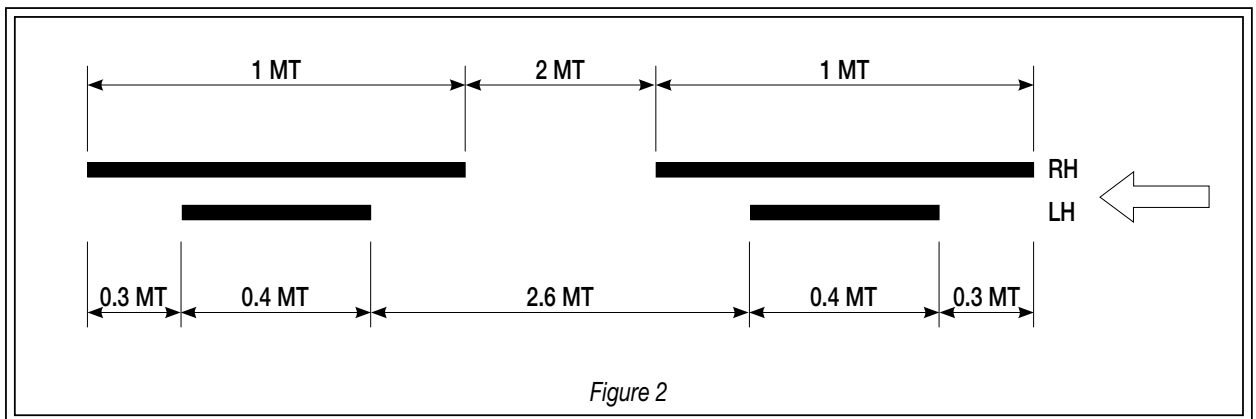

Example of programming to obtain the spray shown in "Figure 3"

RH line	1 MT	LH line	1 MT	LH delay spraying	0 MT
RH space	1 MT	LH space	1 MT	Control	LH=T RH=T

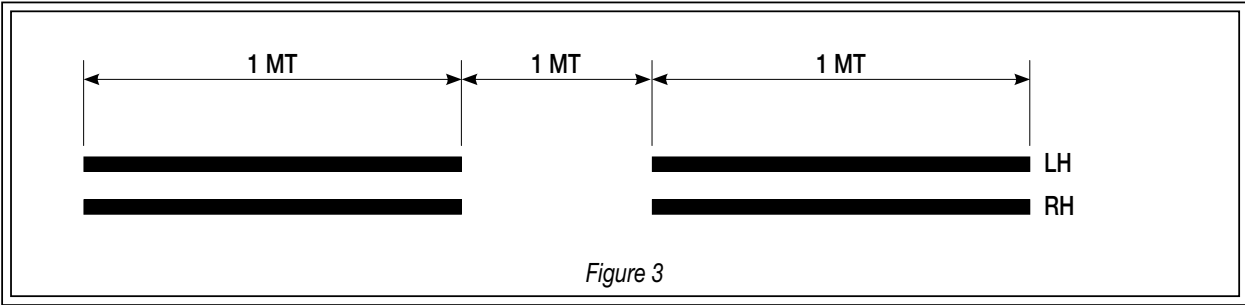

Example of programming to obtain the spray shown in "Figure 4"

RH line	1 MT*	LH line	1 MT	LH delay spraying	0 MT
RH space	1 MT*	LH space	1 MT	Control	LH=T RH=T

\*Not considered as the RH gun is in continuous mode

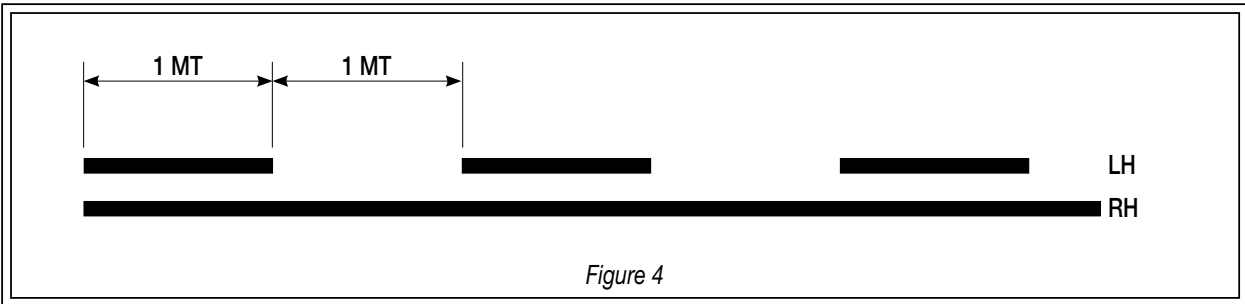

Programming of other spray types has remained unchanged.

Example of programming to obtain the spray shown in "Figure 5"

RH line	1 MT	LH line	0,5 MT	LH delay spraying	0 MT
RH space	1 MT	LH space	1,5 MT	Control	LH=T RH=T

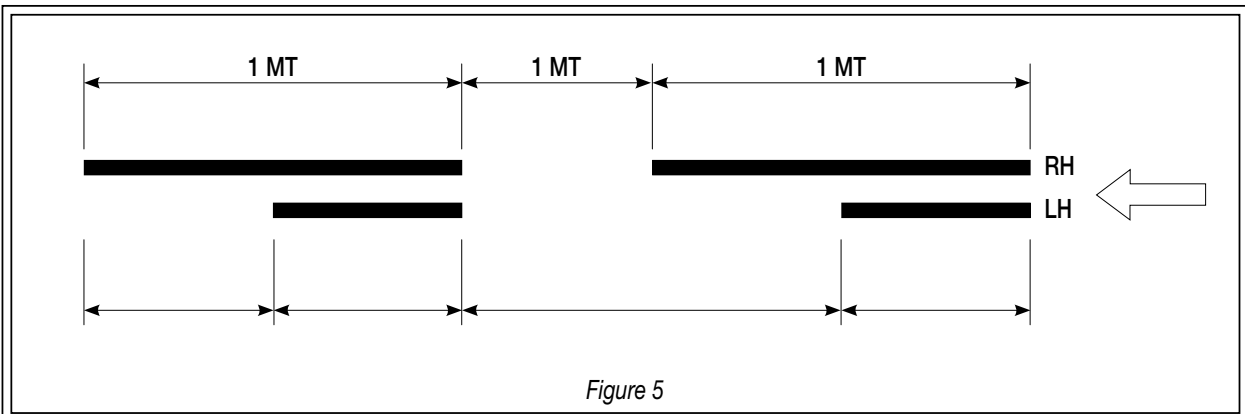

## L SETTING-UP

### CONNECTION OF THE GUNS

- Connect the high pressure hoses (1) to the pump and guns (2), taking care to fasten the connections tightly (*we recommend using two wrenches*).
- It is recommended to use the hose provided with the standard kit. **NEVER** use a damaged or a repaired flexible hose.

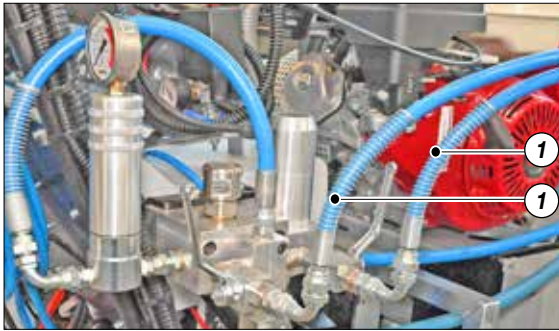

Fig. 1

### CONNECTION OF THE MANUAL GUN

- Connect the high pressure flexible hose (3) to the fitting (4) and the gun (5) tightening the fittings strongly (*the use of two wrenches is suggested*).

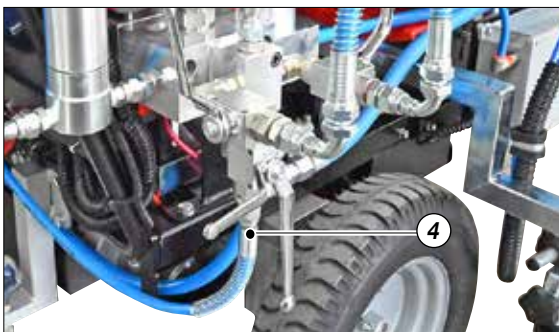
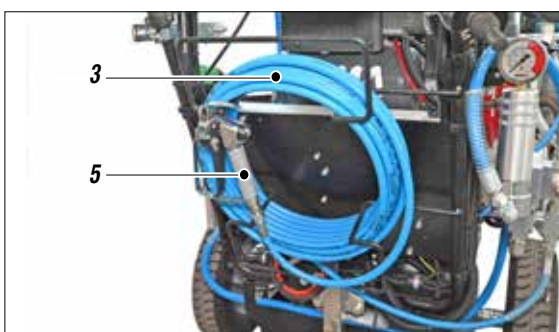

Fig. 2



### WASHING OF THE NEW EQUIPMENT

- The equipment has already been adjusted at our factory with light mineral oil left inside the pumping group as protection. Therefore, wash with diluent before sucking the product.
- Fill the tank with washer fluid and open the inlet valve to the pump.
- Ensure the guns (2-5) are without nozzle.



Fig. 3

- Pull lever (6) for first start-up (*only when cold*). Open the fuel tap (7).

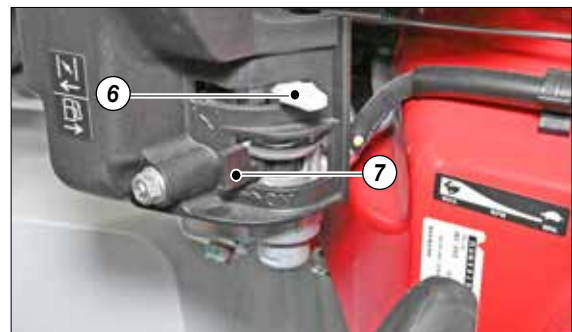

Fig. 4

- Bring the accelerator lever (8) to about 1/2 of its run

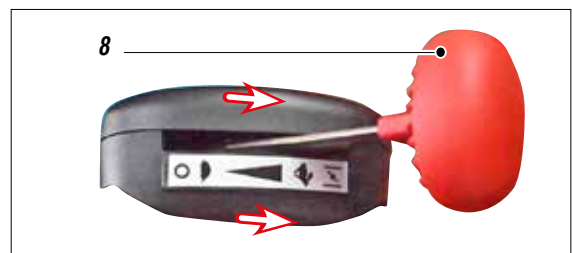

Fig. 5

- Rotate the key (9) to enable the electric ignition.



Fig. 6

- Turn the equipment's switch (10) to **ON (I)** in order to enable the control Head Liner panel.
- Close the re-circulation valve (12).

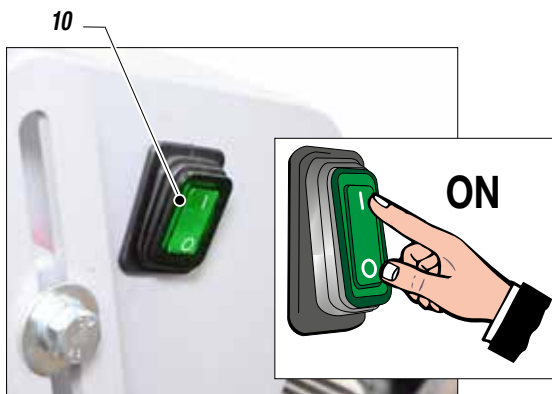

Fig. 7

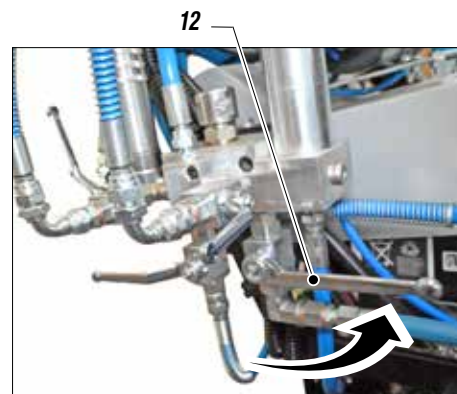

Fig. 11

- Turn pressure regulating knob (11) clockwise a little so that the machine idles.
- Open the manual gun valve (14).



Fig. 8

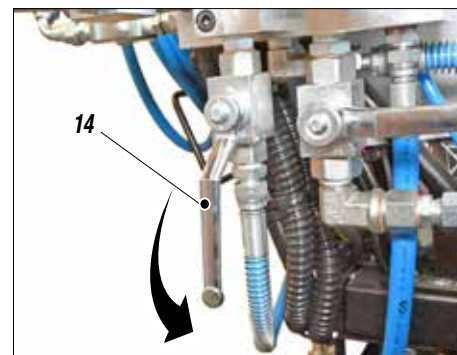

Fig. 12

- Open the re-circulation valve (12).

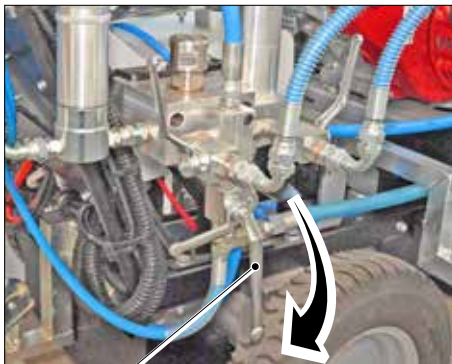

Fig. 9

- Point the manual gun (5) at a container (15) and keep pressed the trigger lever (so as to drain the oil inside) till a clean solvent comes out. Now, release the lever.

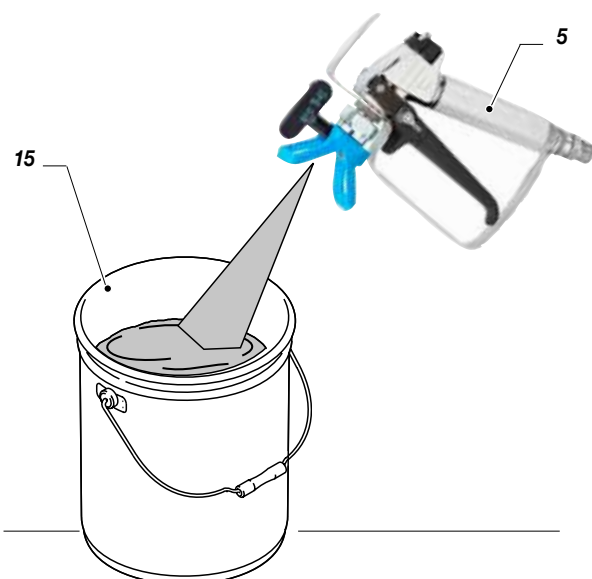

Fig. 13

- Visually check that the wash fluid starts to re-circulate within the tank (13).

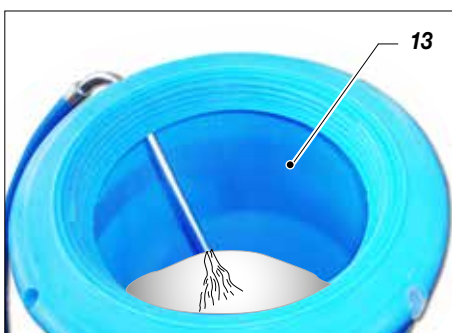

Fig. 10

- Close the manual gun valve (14)

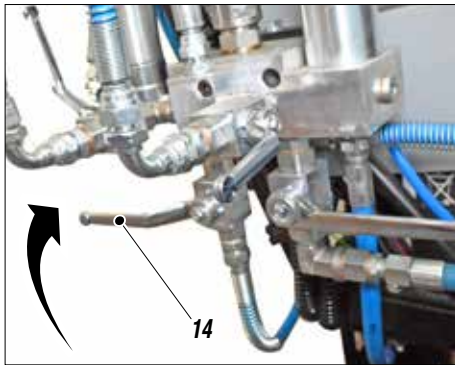

Fig. 14

- Open the valves (16) of the automatic guns.

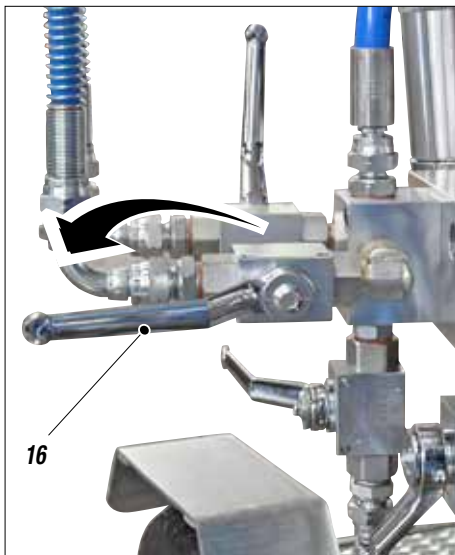

Fig. 15

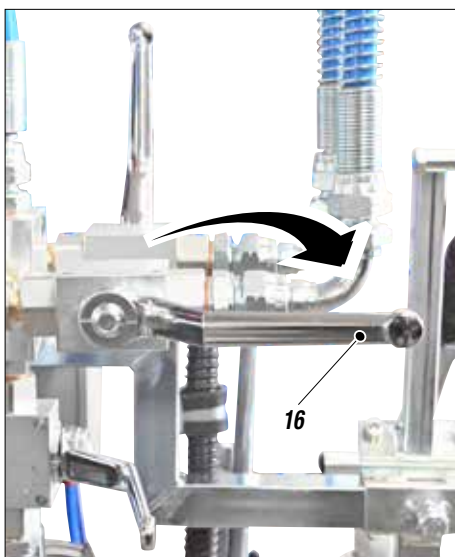

Fig. 16

- Perform the same operation for the automatic spray guns as well (*see Head Liner control bridge instructions*).
- Eliminate any solvent which remains within the tubes by activating the manual and automatic guns.
- As soon as the pump begins to run dry, turn the knob (11) to minimum to stop the system.



**Absolutely avoid spraying solvents in closed environments. It is also recommended to keep the spray gun away from the pump in order to prevent vapours from coming into contact with the electrical motor.**

- Stop the combustion engine.
- At this point the machine is ready. If water-based paints are to be used, after the wash with solvent wash the tank again with soap and water, then rinse with clean water (*repeating the previously described procedures*).
- Insert the manual gun trigger lock and assemble the nozzle.
- Insert the automatic guns trigger lock and assemble the nozzles.

#### PREPARAZIONE DELLA VERNICE

- Make sure the product is suitable to be used with a spray gun.
- Mix and filter the product before using it. For filtration use CLOSE-MESH (ref. LA214).



**Make sure the product to be used is compatible with the materials employed for manufacturing the equipment (*stainless steel and aluminium*). Because of that, please contact the supplier of the product.**

- Fill the tank (13) with the paint.

Never use products containing halogen hydrocarbons (*as methylene chloride*). If these products come into contact with aluminium parts of the equipment, can provoke dangerous chemical reactions with risk of explosion.

## M WORKING

### SETUP PROCEDURE

- Use the tooling after performing all the **SETTING UP** operations above described.
- Make sure that all the levers are in the “**DISENGAGED**” position.
- Check that the automatic lever (1) is in its neutral position.

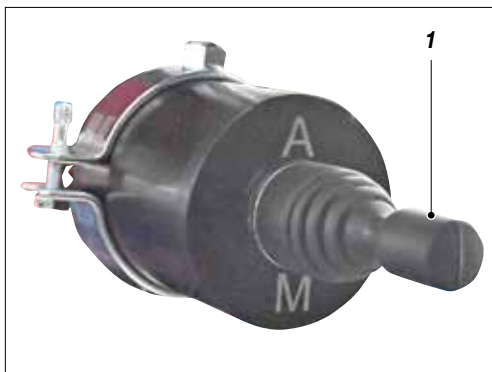

Fig. 1

- Check that there is enough unleaded petrol. Open the fuel tap (2).



Fig. 2

- Enable the engine ignition control with the key (3)



Fig. 3

- Open the re-circulation valve (4).
- Turn pressure regulating knob (5) clockwise a little so that the machine idles.
- Visually check that the product starts to re-circulate within the tank.
- Close the re-circulation valve (4).
- Open the valves (6) of the automatic guns.
- Open the valve (7) (if necessary only for painting with the manual gun).
- Turn the pressure adjustment handle (5) to the necessary operating value (120 ÷ 190 bar).

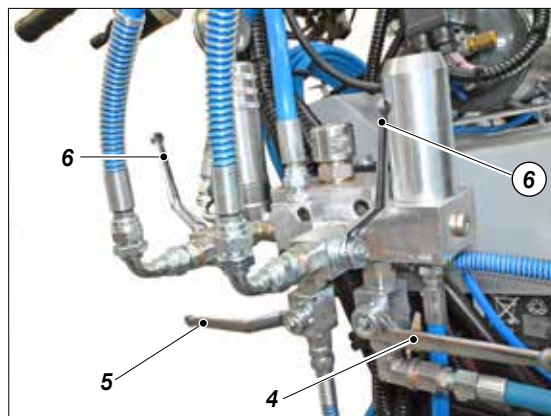

Fig. 4

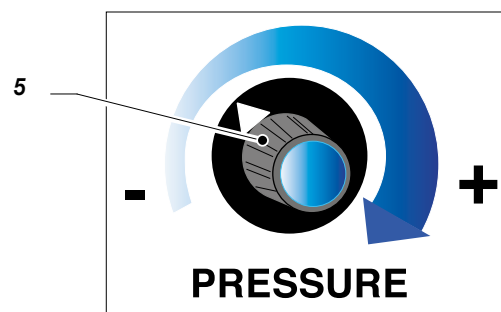

Fig. 5

- Activate the compressor (8) (adjust the compressor's pressure to 6 bar).

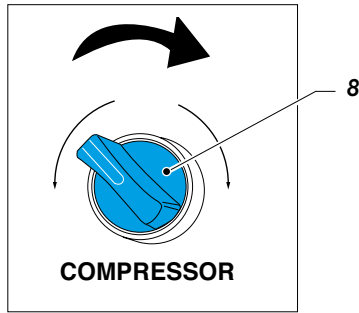

Fig. 6

- Release the clutch using the lever (9), in order to be able to move the machine more easily and accurately.

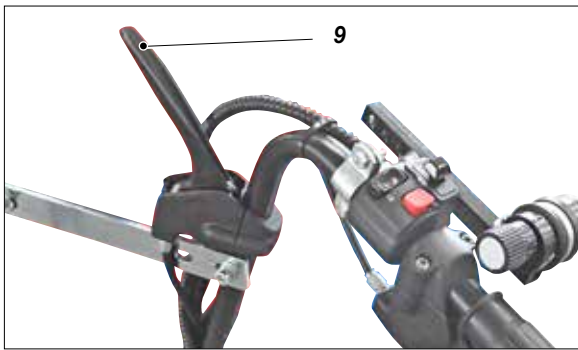

Fig. 7

### ADJUSTING PUMP UNIT SPEED

- Move the motor acceleration lever (10) gently to increase or decrease the speed of the pump. During the painting operation it is normally recommended to maintain the position of the accelerator lever (10) at about 3/4 of its run.

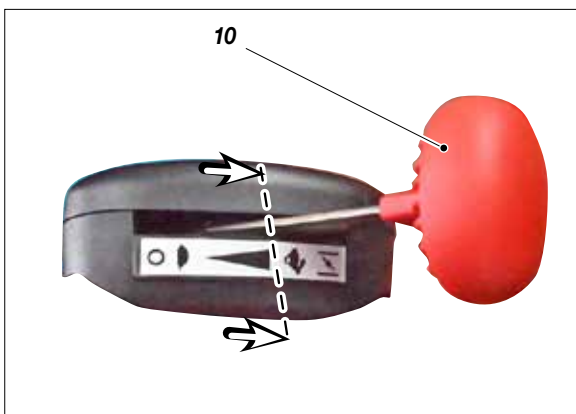

Fig. 8

## N PAINTING OPERATIONS

- In order to use the spray-guns, open the valve (1). In this manner all line-marking spray-guns will have the possibility of dispensing paint by acting on the relevant manual gun lever or the automatic gun levers.



Fig. 1

- To set the working conditions (manual gun or automatic gun operations), switch the control lever (2) located on the right handle to the "A" (AUTOMATIC) position or to the "M" (MANUAL) position.



Fig. 2

- The machine is equipped with a third manual (3) gun with a 15-meter tube (4) to perform roadside writings with paint templates. The gun is situated under the control handles placed on the special tube winder.
- In order to use the manual spray-gun, open the valve (6) located at the intake filter's outlet

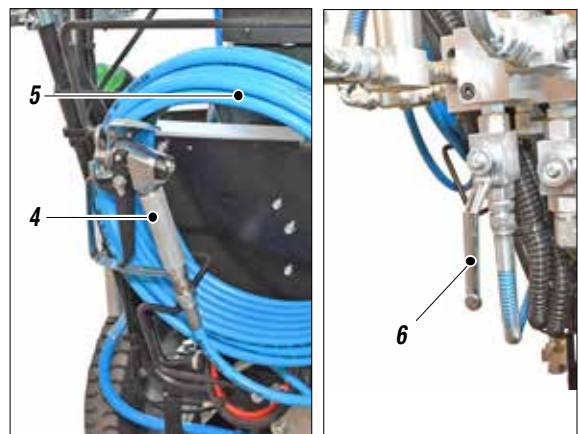

Fig. 3

- If operation is required upon a long rectilinear section, the lever (6) must be released. A spring-action mechanical stopper will automatically block the front wheel (7) in its straight position, thereby ensuring a straight trajectory for the operator.

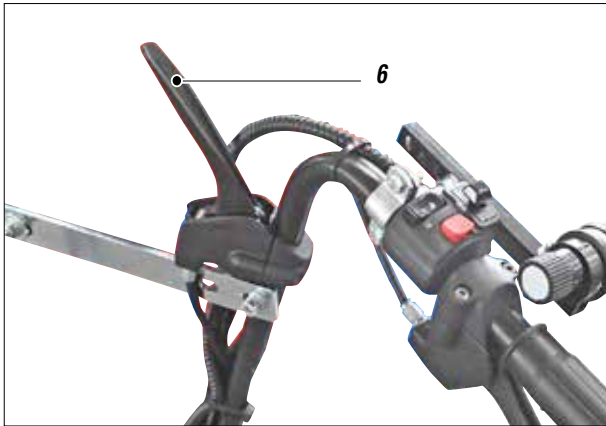

Fig. 4



Fig. 5

- Press the advancement lever (9) and begin to work based on the set cycle by activating the gun control lever "Automatic" or "Manual" (3).

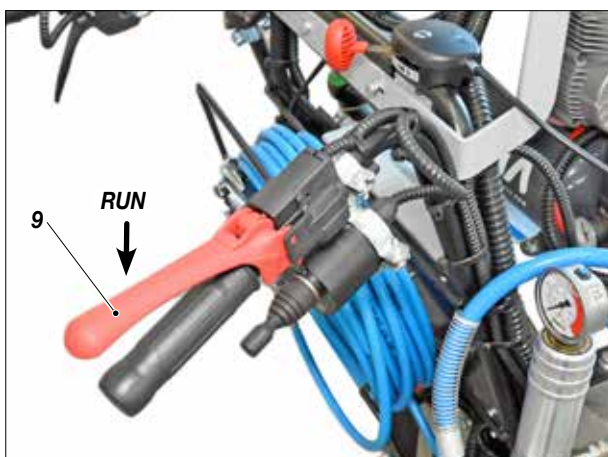

Fig. 6



Fig. 7

### SPRAY ADJUSTMENT

- Slowly turn clockwise the pressure control knob to reach the pressure value in order to ensure a good atomization of the product.
- An irregular and marked spray on the sides indicates a low working pressure. On the contrary, a too high pressure causes a high fog ("overspray") and waste of product.
- In order to avoid excess paint pressure, do not spray if not simultaneously advancing with the machine.
- Always paint with regular parallel bands coats (*manual guns*).
- Keep a safety and constant distance between the gun and the support to be painted and also keep yourselves perpendicular to it.



**NEVER** point the spray gun at yourselves or at other people. The contact with the casting can cause serious injuries.



In case of injuries caused by the gun casting, seek immediate medical advice specifying the type of the product injected.



**Recirculation - safety valve:** when working at the maximum pressure available, releasing the gun trigger sudden increases of pressure can occur. In this case, the recirculation - safety valve opens automatically eliminating part of the product from the recirculating tube. Then it closes so as to go back to the first working conditions.



After the unit's use, follow all procedures for decompression and cleaning indicated in the attached maintenance and use manual. Upon completion of work, switch the lever into the resting position.

## O GLASS BEAD DISPENSER SYSTEM

### DESCRIPTION OF THE EQUIPMENT

With the new glass bead dispenser system of reflecting pearl, the “**EVEREST TH LINER**” unit can produce a system of more visible and therefore safer roadway indication, even in the worst weather.

The glass bead dispenser unit is composed of a dispenser tank with two openings, two rubber bead feeding tubes that carry the glass beads to the distributors.

Pos.	Description
1	Dispenser tank
2	Glass bead feeding tubes
3	Glass bead gun
4	ON/OFF valve

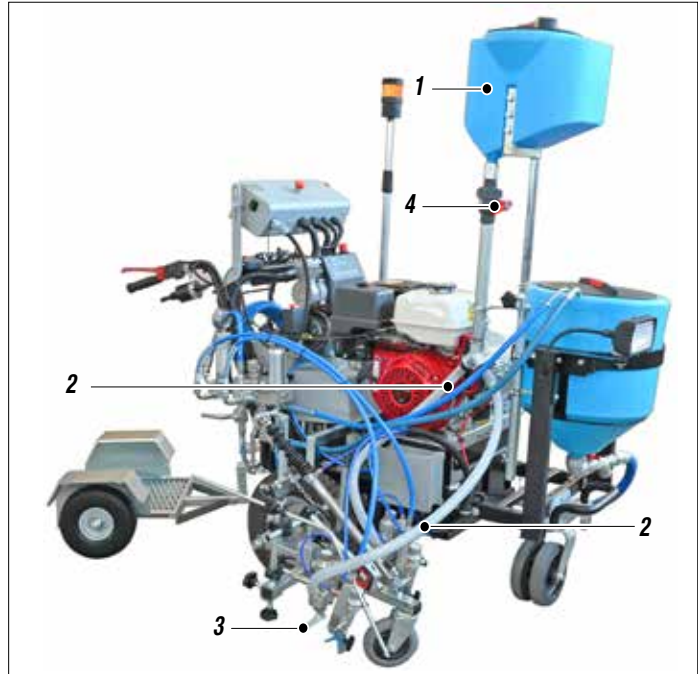

Fig. 1

## P SETTINGS

### SETTING THE POSITION OF THE GUN-LASER POINTER-GUIDE ROD UNIT

To set the position of the gun-laser pointer-guide rod unit (1) and allow the movement indicated by the arrow, act on the handles (2) (3).

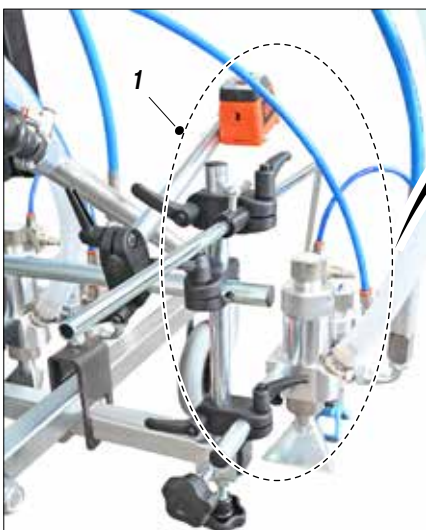

Fig. 1

Act on the handles (5) positioned on the opposite side to set the position of the second gun unit (4) allowing the movement indicated by the arrow.

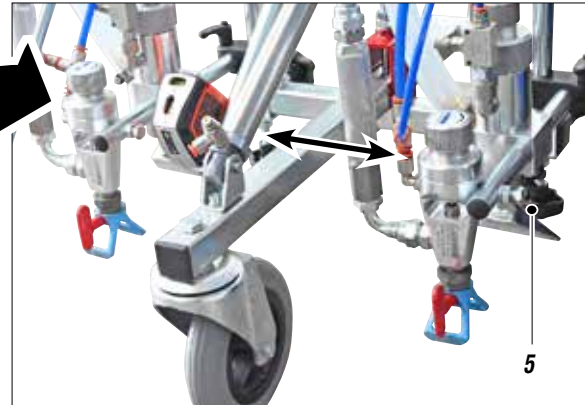
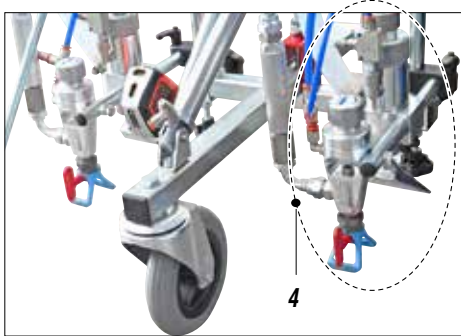

Fig. 2

### SETTING THE POSITION OF THE GUNS

To set the position of the automatic guns (6) (7) and of the glass bead guns (8) (9) act on the handles (10) (11) and (12) (13) to allow the movement indicated by the arrows.

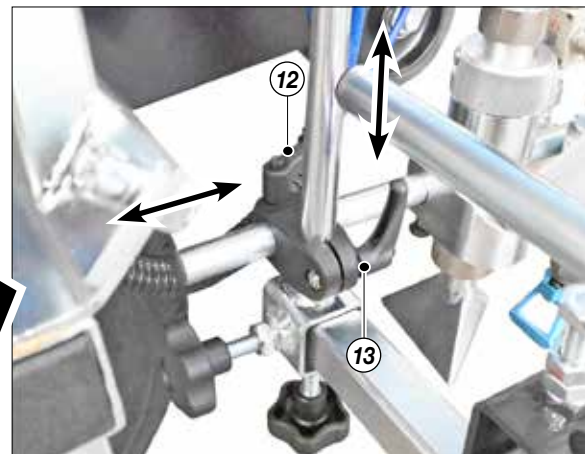
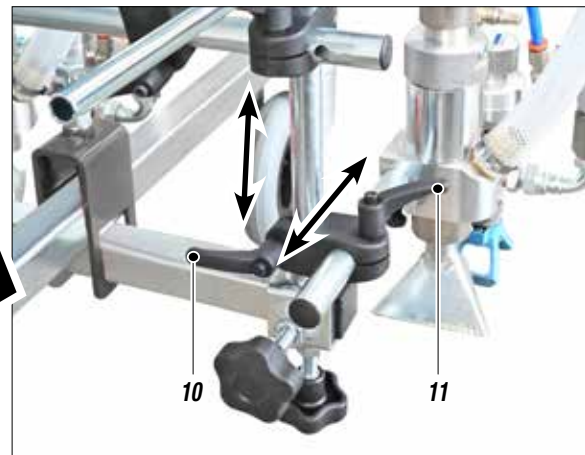
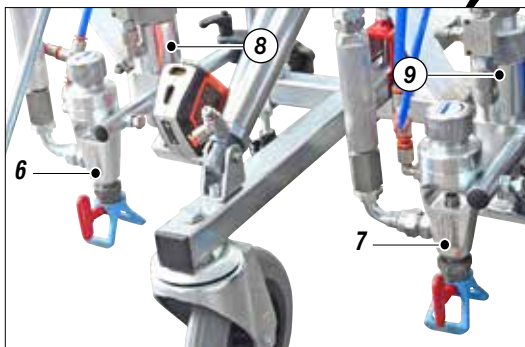

Fig. 3

### SETTING THE POSITION OF THE GUIDE ROD

In order to adjust the position of the guide rod (14) act on the handles (15) (16) to allow the movement indicated by the arrows.

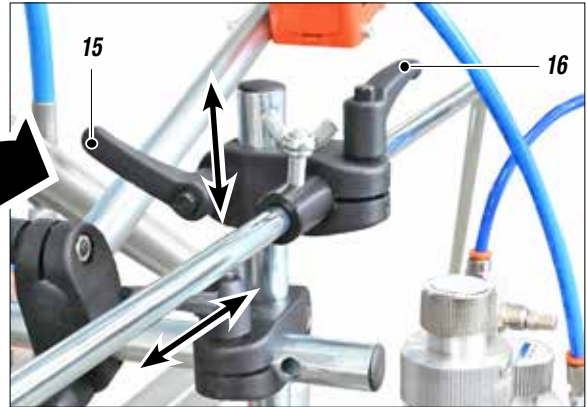
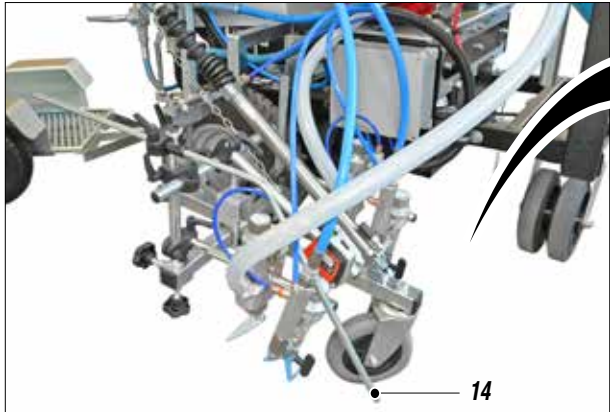

Fig. 4

### SETTING THE POSITION OF THE LASER POINTER

In order to adjust the position of the laser pointer (17) act on the handles (18) (19) (20) (21) to allow the movement indicated by the arrows.

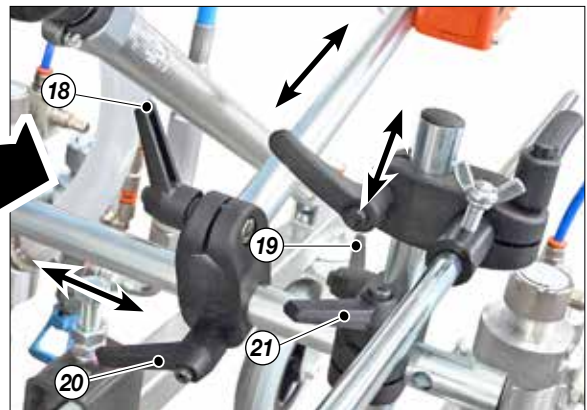
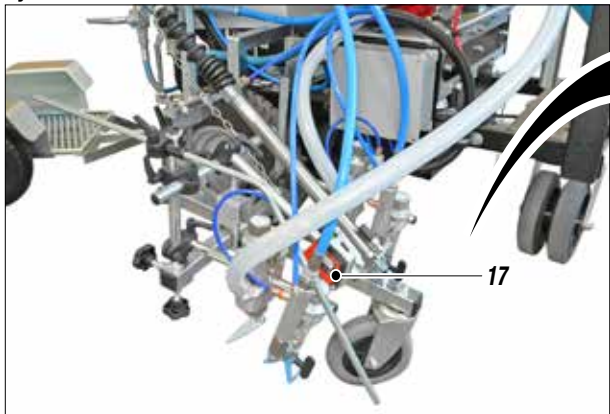

Fig. 5

### SETTING THE PNEUMATIC SYSTEM PRESSURE



Before adjusting the pressure, start the compressor using the button (22).

In order to regulate the pressure in the pneumatic system, turn the knob (23) clockwise (+) to increase the pressure and anticlockwise (-) to reduce it.

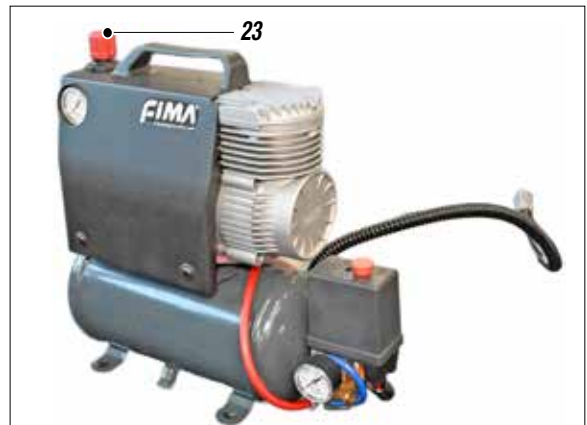
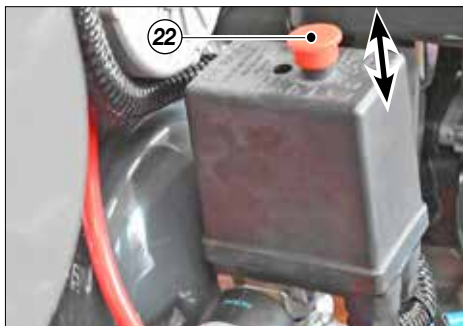

Fig. 5

## Q CLEANING AT THE END OF THE WORK

- Reduce pressure to the minimum [*turn counterclockwise the pressure control knob (1)*].

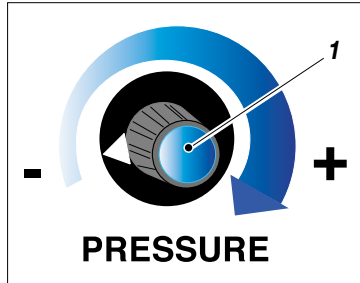

Fig. 1

- Press the switch (2) placed on the box of the electric motor, to stop the equipment.



Fig. 2

- Open the safety valve (3) to release the pressure in the circuit.

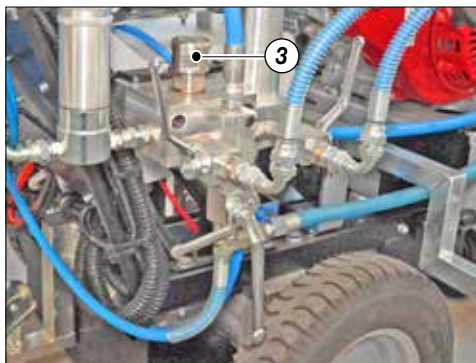

Fig. 3

- Eliminate any paint which remains in the tank (4) by placing the recirculation tube (5) into a container.

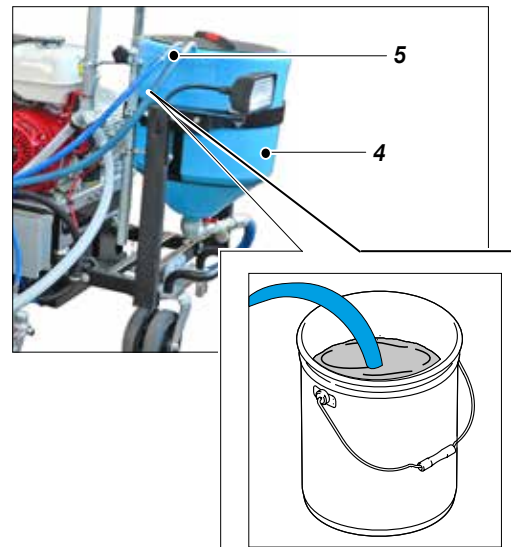

Fig. 4

- Turn the pressure adjustment (1) knob slightly clockwise to make the machine function at minimum pressure (pump activated).
- Empty the tank (4).
- Turn the pressure adjustment (1) knob to minimum (pump stopped).
- Insert wash fluid into the tank.
- Clean the walls of the tank with a brush.
- Turn the pressure adjustment (1) knob slightly clockwise to make the machine function at minimum pressure (pump activated).
- Make sure the re-circulation tube is inserted into a container and wait for clean wash fluid to come out of it (clean).
- Turn the pressure adjustment (1) knob to minimum (pump stopped).
- Close the re-circulation valve (3).

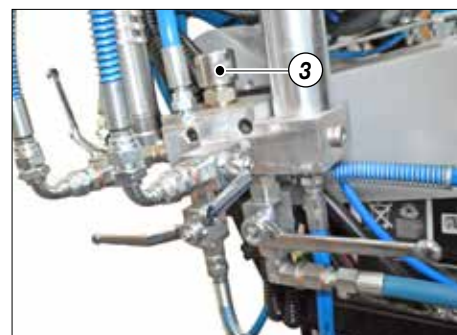

Fig. 5

- Reposition the re-circulation tube within the tank.
- Remove the nozzles from the guns and wash them separately.
- Turn the pressure adjustment (1) handle slightly clockwise to make the machine function at minimum pressure (*pump activated*).

- Point the manual gun (7) into a container (8), drain the residual paint and wait for the wash fluid to come out clean.

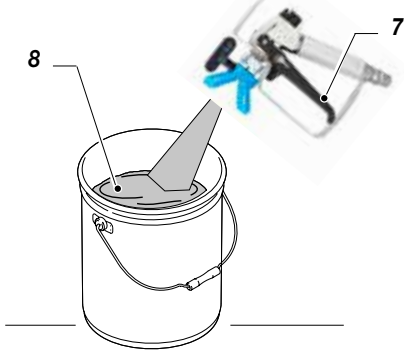

Fig. 6

- Set the RH and LH guns simultaneously **MENU 1** function from the control panel.
- Move the control lever to position "C" and unload any residual paint. Wait for the cleaning liquid to come through clean.
- Remove all clearing liquid from the tank and turn the machine off.
- Turn the pressure adjustment (1) handle to minimum (pump stopped).



Follow the washing procedure before using again the equipment.

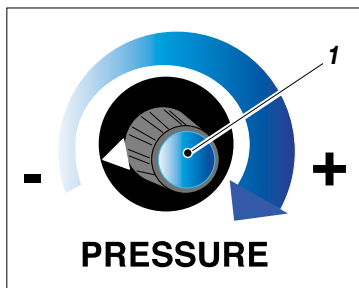

Fig. 7

## R GENERAL MAINTENANCE

### DAILY

- Clean the filters;
- Clean the nozzles;
- Clean all the varnish circuit with a specific product;
- Check the fuel motor (*see the maintenance table*).

### PERIODICALLY

- Check the pumping gaskets draft (*if the product draws, replace gaskets*);
- Clean the mobile parts from the varnish deposits (*clutch traction, spray guns, etc.*);
- Check the gun cables tightening, the wheel block and the traction;
- Check that the tubes and all the fittings are correctly locked.

## S ROUTINE MAINTENANCE

### CHECKING THE MOTOR OIL

Check the motor oil with a dipstick (3) every 100 working hours via the relevant inspection spots (1) (2) positioned on the bottom of the petrol motor.  
Top up if necessary.

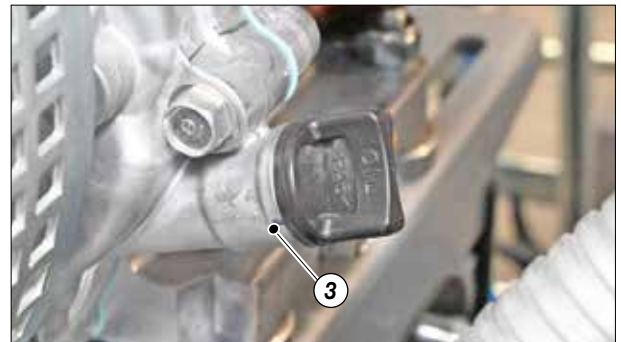
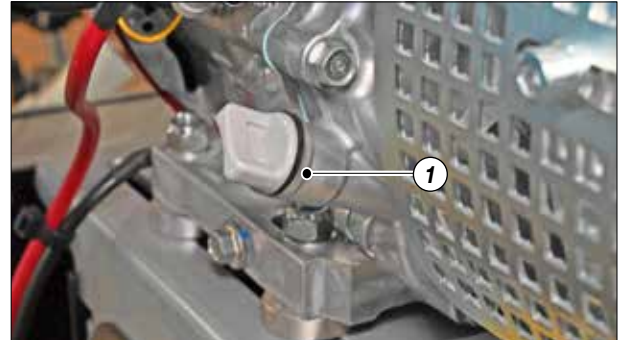
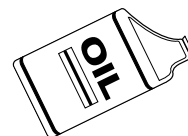

Fig. 1



Fig. 2



## PACKING NUT CHECK

The gaskets do not need adjusting. The ring nut is only used to fit and remove gaskets and for topping up the oil..



**Always disconnect the electrical supply and discharge the pressure in the pump unit (*open the discharge valve*) before carrying out any maintenance. Wait 30 seconds before proceeding with maintenance operations to allow any residual electricity to be discharged.**

- Use the lubricant (1) provided (Ref. 16340) to make it easier to slide the piston inside the seal pack and to substitute the air with oil.

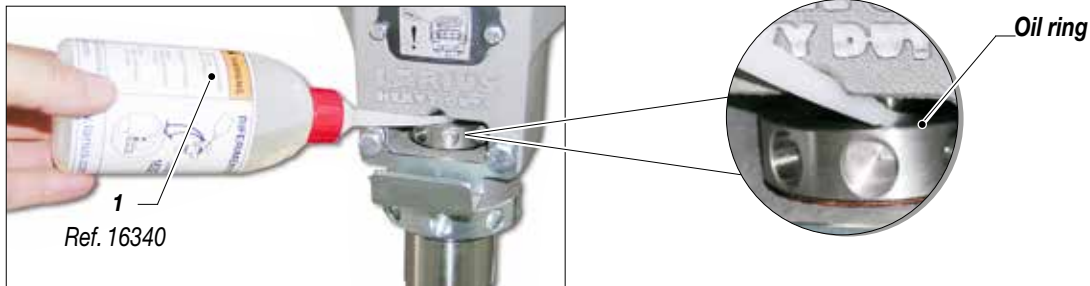

Fig. 3



**At the beginning of each working day check that the ring nut is full of hydraulic oil. This oil makes it easier for the piston to slide and prevents any material that escapes via the seal gasket drying when the equipment is stopped.**

- The ring nut (2) must be tightened all the way. Every 100 working hours, with the pressure at 0 bar, check that it is tightened all the way.
- The pin (3) supplied (Ref. 20144) is used to tighten and open the pump unit (4) locking ring nut, which must always be tight to act as a locknut.

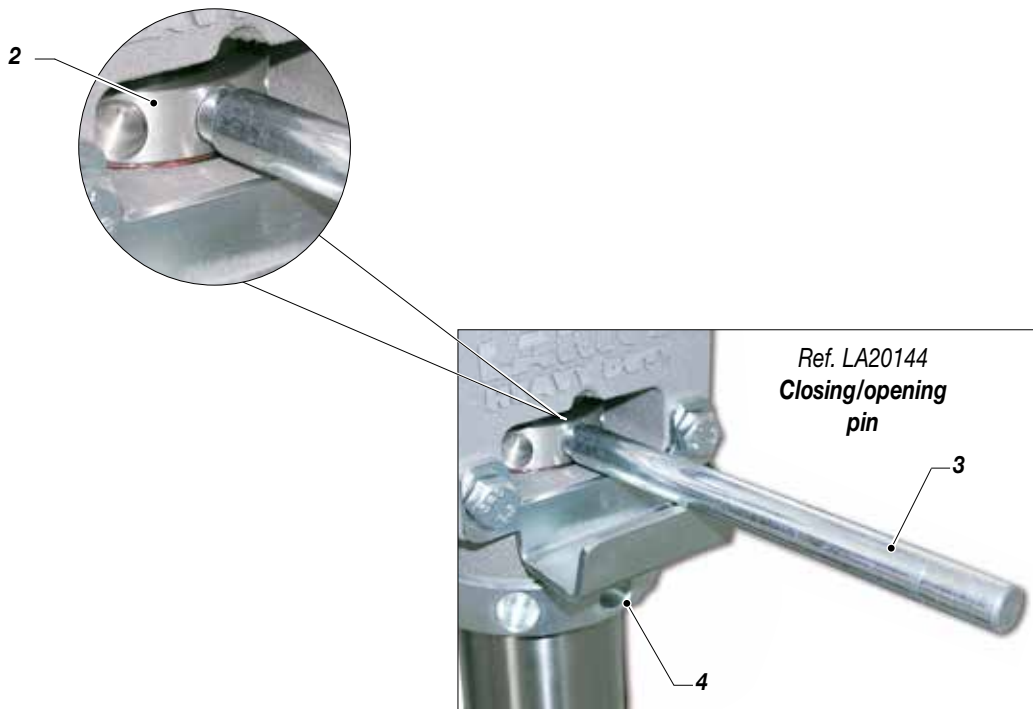

Fig. 4

### PRESSURE SWITCH SEAL CHECK

Check that no material is escaping from the safety hole (5) at the bottom of the protective container.  
If necessary, replace the O-Ring for the pressure sensor (6).

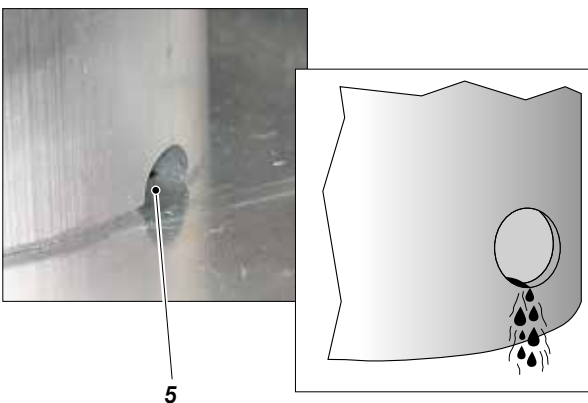
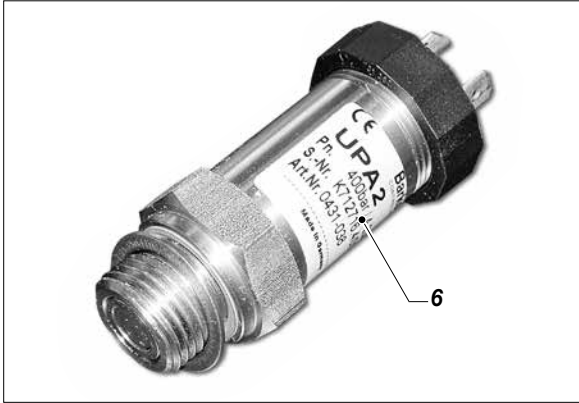

Fig.

## T CHARGING THE BATTERY

The **EVEREST TH LINER** is provided with an internal combustion engine, mounted on the trolley that drives the reciprocating piston pump and the alternator used to charge the battery pack.



Handle the **EVEREST TH LINER** line marking equipment without the internal combustion engine running only for short distances and for short periods.



If the equipment is handled for long distances without the internal combustion engine running, the battery pack drops below the minimum threshold level and the equipment locks up.

Start the internal combustion engine to reset and recharge the battery pack.



If the machine is not used for long periods, it is necessary to start the internal combustion engine at least once a month.

Therefore, leave the engine running for a certain period of time to allow optimal recharging of the battery pack.

If the batteries are worn out, replace them (see the page on *Battery pack spare parts*)

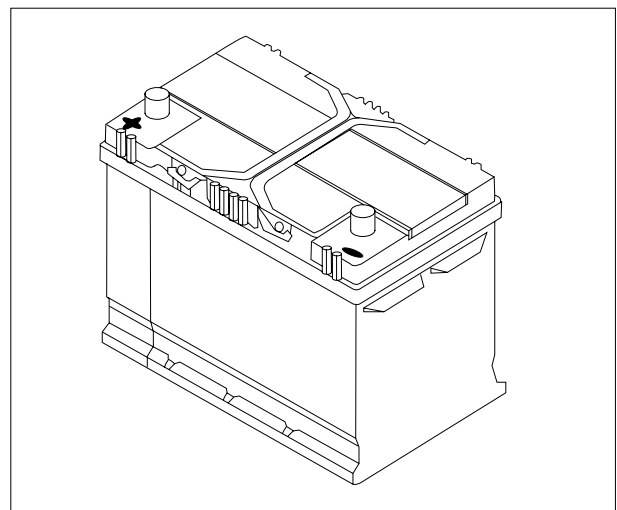

## U CORRECT PROCEDURE OF DECOMPRESSION

- Move the switch (1) to the **OFF** position to stop the equipment.

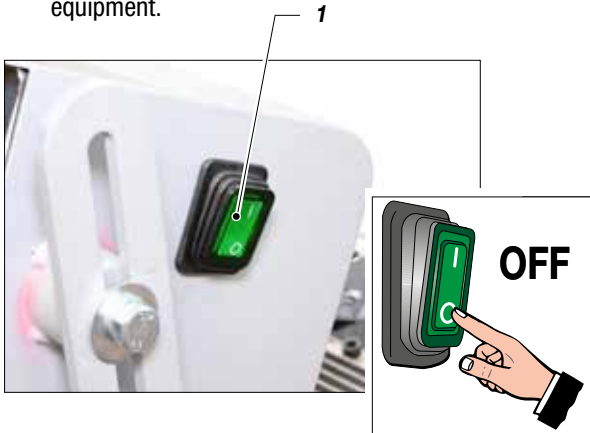

- Unlock the safety clamp (2).

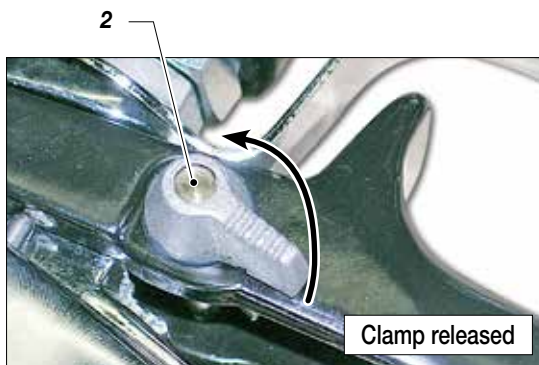

- Point the gun (3) at the receptacle (4) used to collect the product and press the trigger to release the pressure. When completed, activate the safety catch again.

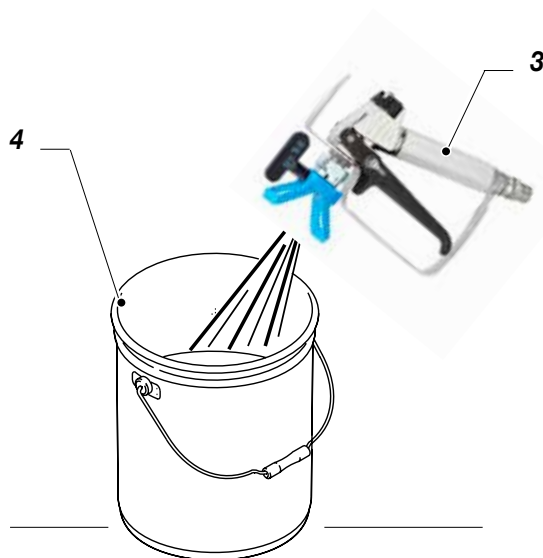

- Open the recirculation valve (5) to release the remaining pressure.



### WARNING:

If the equipment is still under pressure after performing the operations above described because of the nozzle or the flexible hose clogged, proceed as follows:



- Loosen very slowly the gun nozzle.

- Release the clamp.



- Point the gun at the container of the product and press the trigger to release pressure.

- Loosen very slowly the fitting of connection from the flexible hose to the gun.

- Clean or replace the flexible hose and the nozzle.

## V REPLACEMENT OF THE PUMPING GROUP GASKETS

Each time you use the machine, check for material leaking from the top of the ring nut.

If any material leaks out when the pump is working at the set pressure, proceed as follows:



Always disconnect the power supply and release pressure before going on with the operations (*follow the "correct procedure of decompression"*).



The gaskets are self-adjusting. If a leak occurs they must be replaced.

- Disconnect the product feed hose (1) from the pump unit by unscrewing the nut (2).
- Unscrew the fixing ring nut (3) using the relevant closing pin (Ref. LA20144).

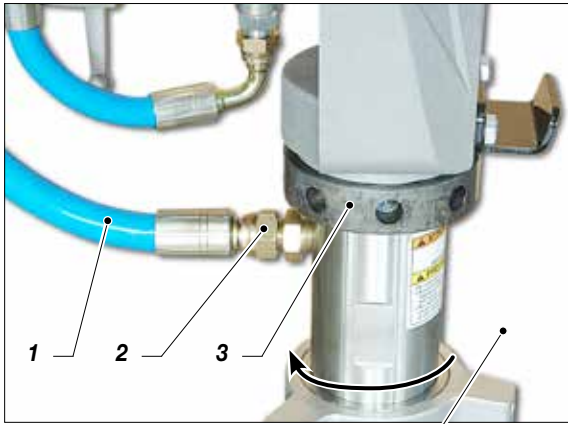

Rif. LA20144

- Release the plastic cover (4).

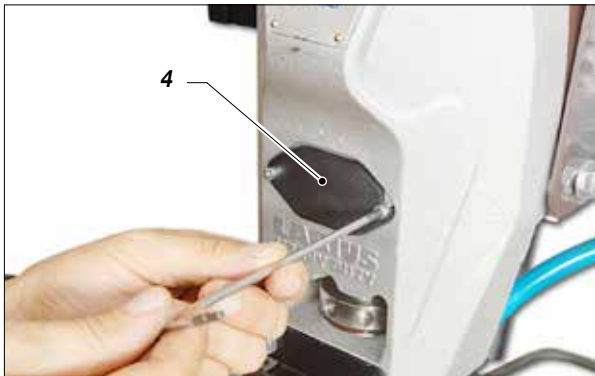

- Put the switch (5) to the **ON** position to start equipment.

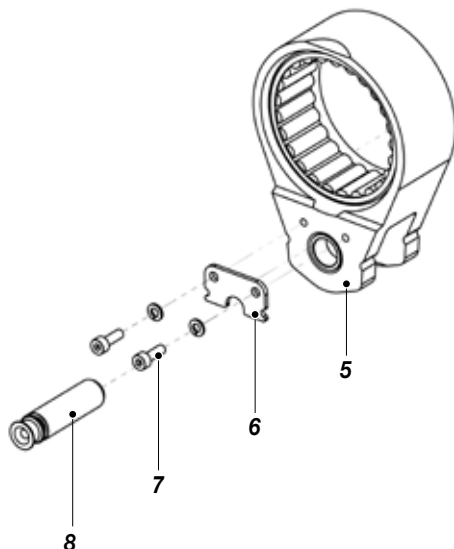

- Remove the screws (7) that secure the locking plate (6) of the pin (8). remove the screw, washer and the locking plate.
- Screw the appropriate supplied tool (9) (Ref. LA20213) into the threaded hole on the holding pin (8).

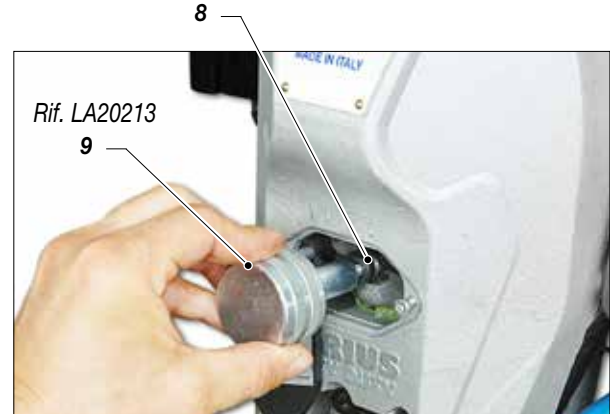

- Remove the pin (8) from its seating.

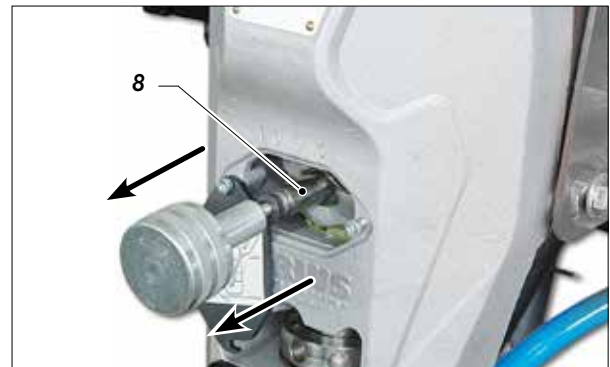

- Unscrew the pump unit (10) from the frontal flange (11).

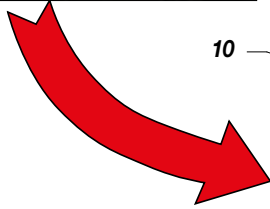

10



### Lower seal

- Remove the piston stem (12) and remove the pump unit sleeve (13);

12

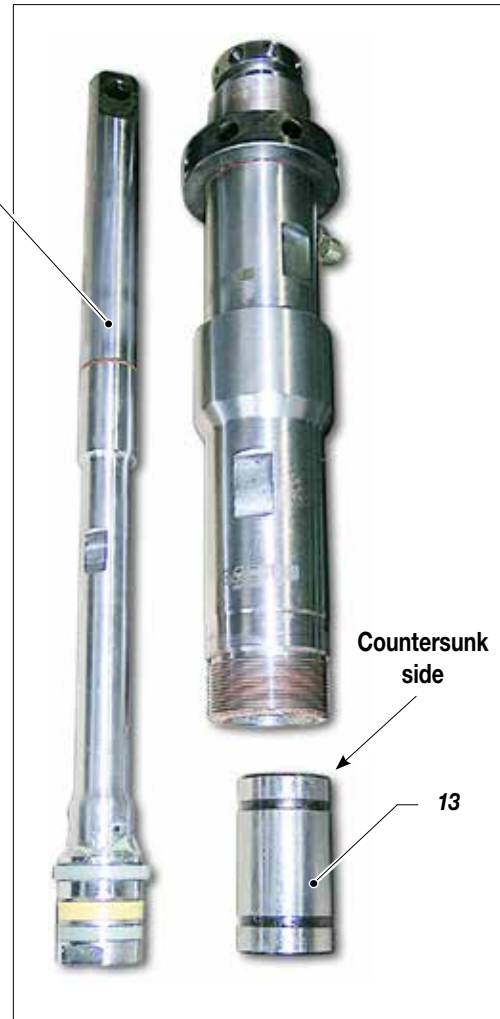

Countersunk side

13

### PIT STOP MAINTENANCE

Replacement of upper and lower gaskets 20 minutes.

- Lock the pump unit into a vice and unscrew it with a 60 mm wrench;
- Release the pump unit from the body of the suction valve;

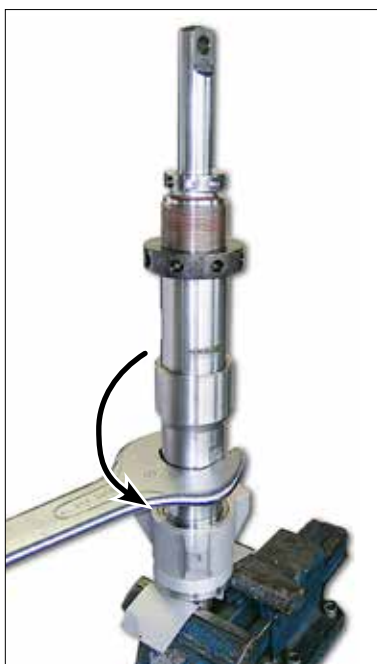

- Grip the stem valve (14) in a vice;

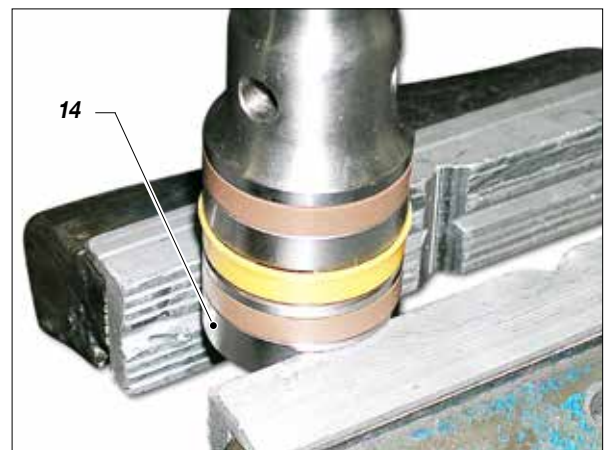

14

- Use a size 24 spanner to unscrew the lower stem (15);

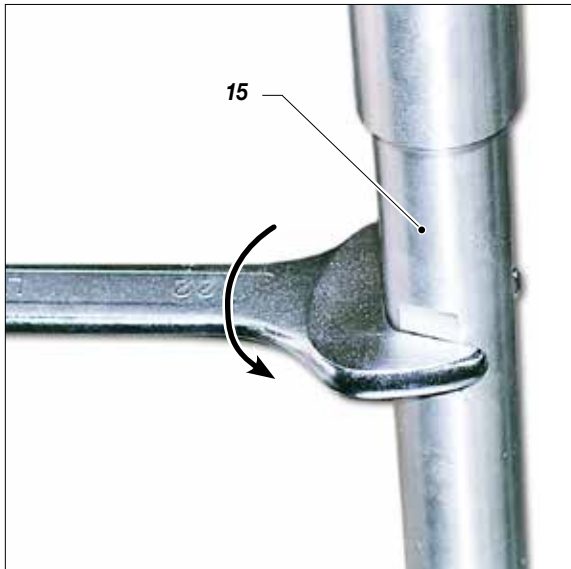

- Unscrew the stem valve (17) altogether, check the surface of the ball seating (18) that comes into contact with the ball (19).  
If worn, replace them;



- Use a screwdriver to remove the two open-ring guide bands (16) and replace them;

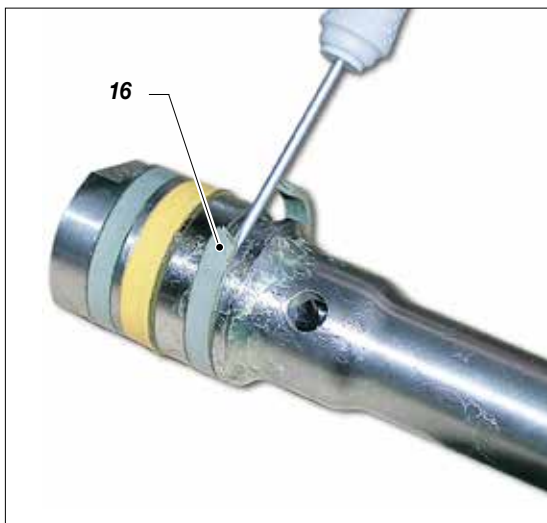

- Use a screwdriver to remove the O-Ring (20) and replace it making sure it is aligned correctly (as illustrated);

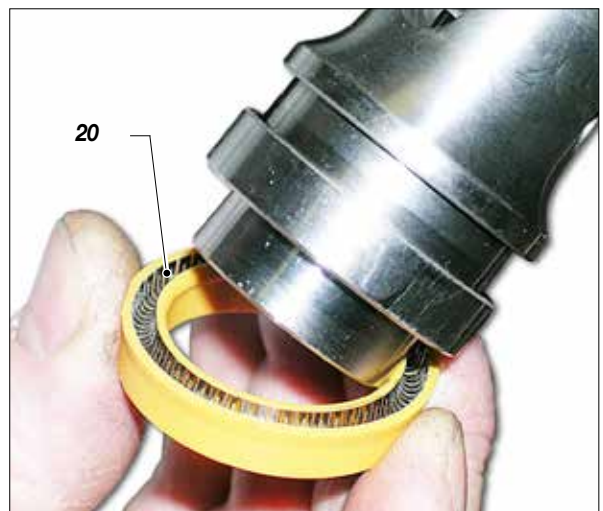
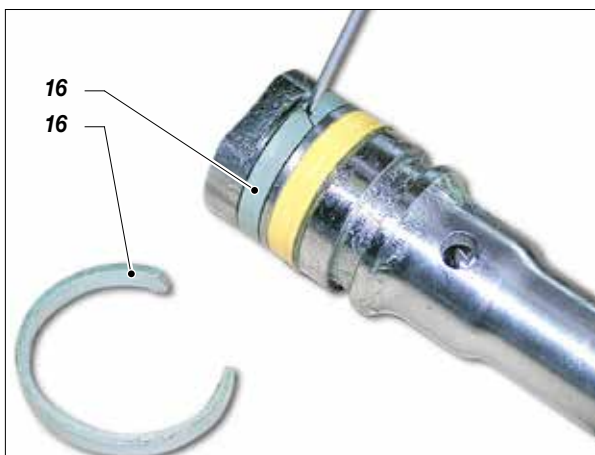

- Screw the valve stem (17) (Ref. 20139) on again and tighten fully, gripping the valve in a vice. To tighten, use a 22 mm spanner;  
The use of a thread paste is recommended;

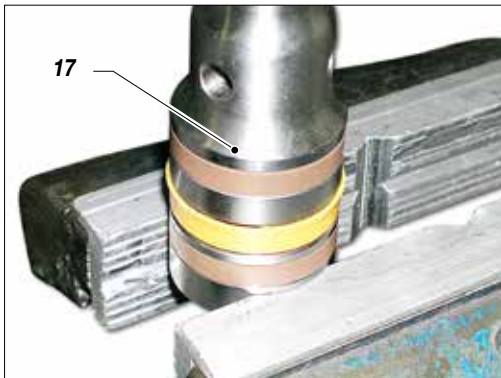

#### Upper seal

- Remove the ring nut (21);

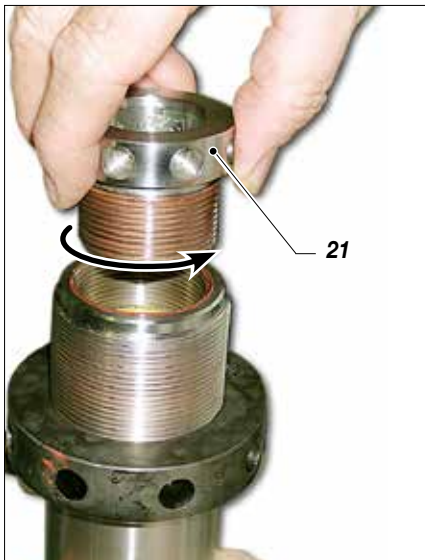

- Remove the guide band (22) with a screwdriver and replace it with a new one;

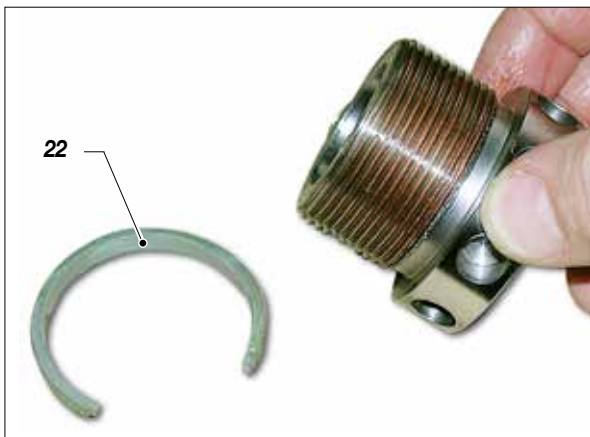

- Remove the seal (23) with a screwdriver;



- Using a screwdriver, remove the second band (24) located below the seal (23) and insert a new band in the same position;



**The positioning of the seal (24) requires special care during assembly.**

- Assist insertion by applying leverage to the outside of the ring (23), pushing from the outside inwards and helping the ring to lodge in the seating, while being careful not to damage the ring's contact surfaces.



**Lubricate with grease before fitting.**

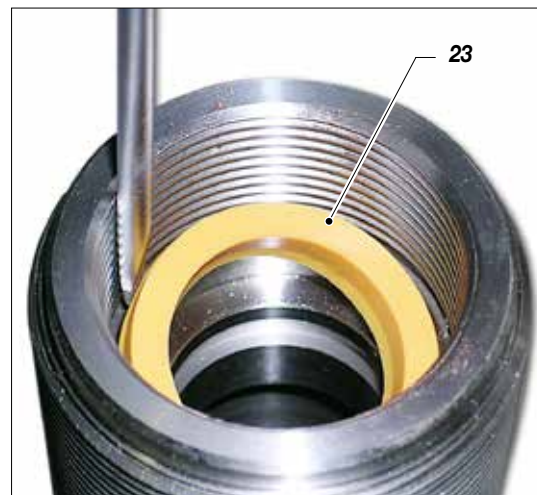

- Remove the OR (25) of the footvalve (26) and the sealing ring (27) and, if necessary, replace. Reassemble the components in their proper order (as indicated in the diagram);

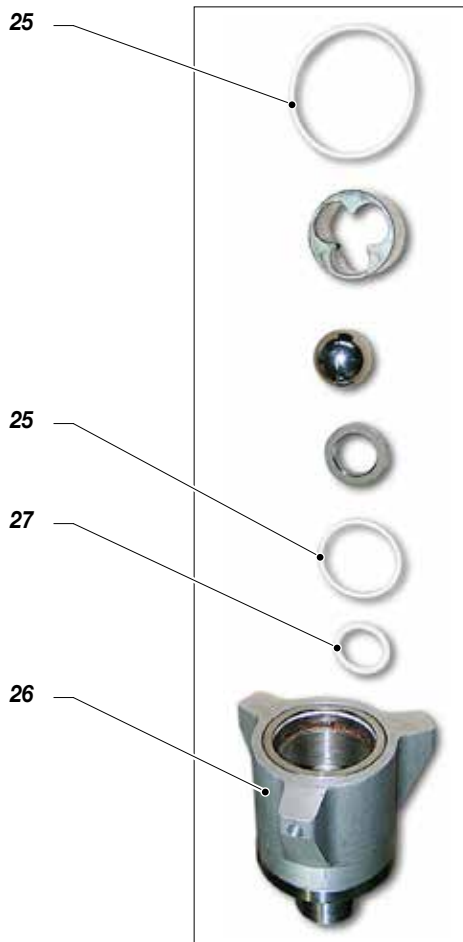

To facilitate fitting the O-ring (26) it is advisable to warm it slightly with a blast of hot air.

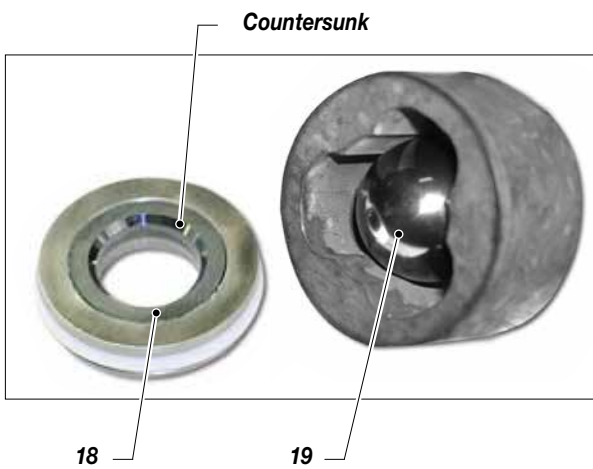

The ball seating (28) is countersunk on one side, where the ball (29) must sit.

- Screw the locking ring nut (21) back onto the body of the pump unit until it makes contact, then loosen it by one turn;



- Remove the sleeve/cylinder seal (28) and replace it with a new one;

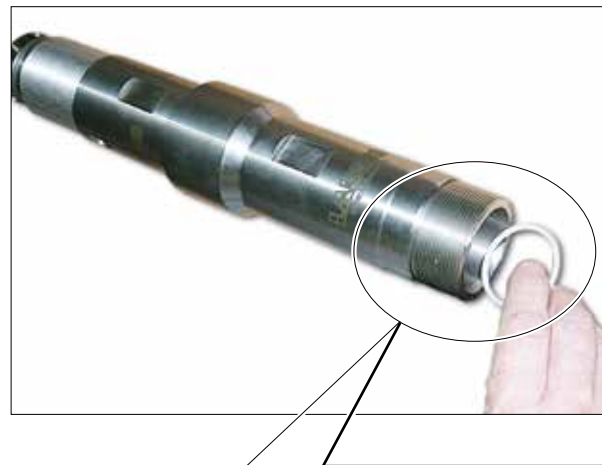

- Check the wear status of the surfaces inside the jacket. Replace it if necessary;
- Grease the sleeve (29) using a paintbrush;

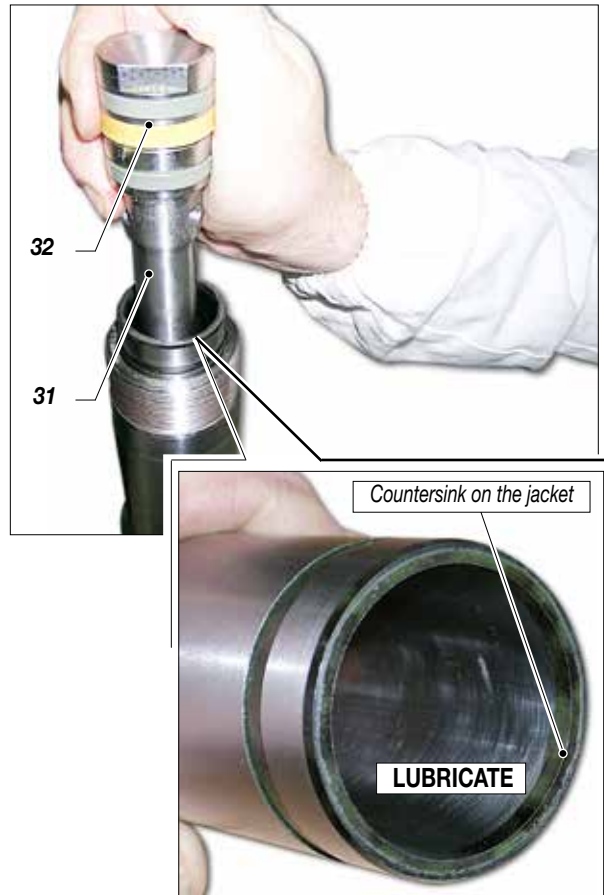

- Insert the sleeve (29) into the lower pump unit (30);

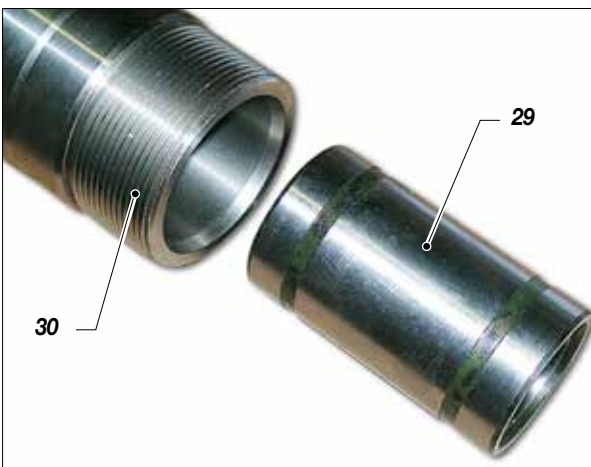

- Screw on the complete foot valve (26) with the sleeve assembly (28);



In order to guarantee a proper seal, tighten the foot valve (26) fully, using a 50 mm spanner.



Insert the complete piston stem (31) after greasing the gaskets (32).

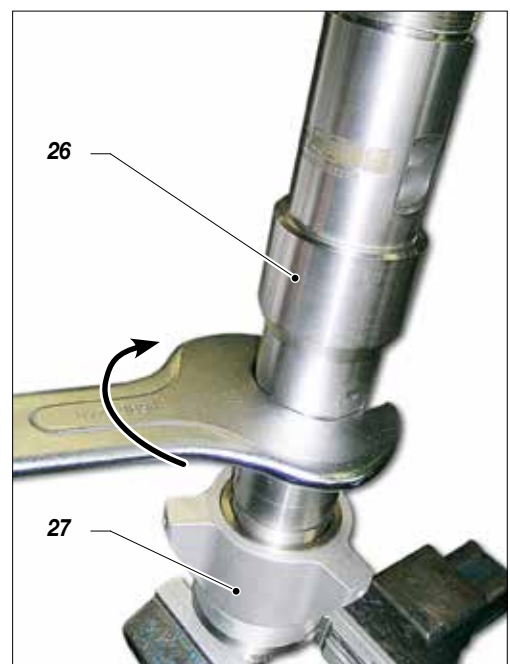

- When refitting the pump unit on the machine, the stem must be at its highest point possible.
- Insert the stem into the connecting rod and insert the fixing pin (9).



- Reposition the plate, washers and screws onto the connecting rod bloccando locking the pin (9).
- Tighten the pump casing all the way and, if the delivery pipe is not correctly aligned, unscrew the pump casing until the connection is in the correct position before tightening by using the ring nut (33) and the pin (34) supplied (Ref. LA20144).

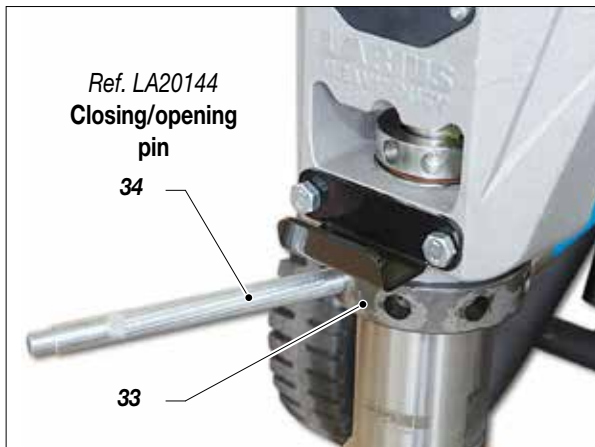

- Close the seal ring nut (35) all the way.



- Lubricate the upper crown (36) using oil (37) (Ref. LA16325);

**Oil ring**



- To assemble all the parts in the correct sequence, see the exploded diagram.



## W PROBLEMS AND SOLUTIONS

Problem	Cause	Solution
<b>Engine won't start</b>	The petrol manifold is closed;	Open the petrol manifold;
	Engine is out of gas;	Refill gas tank;
	Cold engine;	Use choke;
	Spark plug cable is disconnected or damaged;	Connect spark plug cable or replace spark plug;
<b>The equipment does not start</b>	On/Off switch disconnected;	Ensure the On/Off switch is on the "on" position and turn clockwise the pressure control knob;
	Breakdown of pressure transmitter;	Verify and replace it, if necessary;
	Breakdown of motor electric control box;	Verify and replace it, if necessary;
	The line of material coming out of the pump is already under pressure;	Open the drain valve to release pressure in the circuit;
	The product is solidified inside the pump;	Open the drain valve to release pressure in the circuit and stop the machine. Disassemble the pumping group and the pressure transmitter and clean;
<b>The equipment does not suck the product</b>	Suction filter clogged;	Clean or replace it;
	Suction filter too fine;	Replace it with a larger-mesh filter (with very dense products, remove the filter);
	The equipment sucks air;	Check the suction pipe;
<b>The equipment sucks but does not reach the pressure desired</b>	Lack of product;	Add the product;
	The equipment sucks air;	Check the suction pipe;
	The drain valve is open;	Close the drain valve;
	The gaskets of the pumping group are worn;	Replace the gaskets;
	Suction or delivery valve dirty;	Disassemble the pumping group;
<b>When pressing the trigger, the pressure lowers considerably</b>	Nozzle too big or worn;	Replace it with a smaller one;
	The product is too dense;	Dilute the product, if possible;
	The filter of the gun-butt is too fine;	Replace it with a larger-mesh filter;
<b>The pressure is normal but the product is not atomized</b>	The nozzle is partially clogged;	Clean or replace it;
	The product is too dense;	Dilute the product, if possible;
	The filter of the gun-butt is too fine;	Replace it with a larger-mesh filter;
<b>The atomization is imperfect</b>	The nozzle is worn;	Replace it;
<b>When releasing the trigger of the gun, the equipment does not stop (the motor runs slowly and the piston rod keeps on going up and down)</b>	The gaskets of the pumping group are worn;	Replace the gaskets;
	Suction or delivery valve dirty;	Disassemble the pumping group and clean;
	Drain valve defective;	Verify and replace it, if necessary;

# SPARE PARTS



<b>X</b> Pivoting frontal wheel p. 48	<b>Y</b> Paint canister assembly p. 50	<b>Z</b> Speed potentiometer assembly p. 52	<b>AA</b> handlebar controls p. 53
<b>AB</b> Solenoid valve box p. 54	<b>AC</b> Operator footboard p. 56	<b>AD</b> Reverse buzzer p. 57	<b>AE</b> Filter group p. 58
<b>AF</b> Complete short pumping element p. 60	<b>AG</b> Reduction unit p. 62	<b>AH</b> AT250 high pressure spray gun p. 64	<b>AI</b> LA95 spray gun exploded view p. 66
<b>AJ</b> Flow compensator p. 68	<b>AK</b> Battery group p. 69	<b>AL</b> Board V.2.50 p. 69	



Intentionally blank page

# Y PAINT CANISTER ASSEMBLY

**WARNING:** Always indicate code and quantity for each part required.

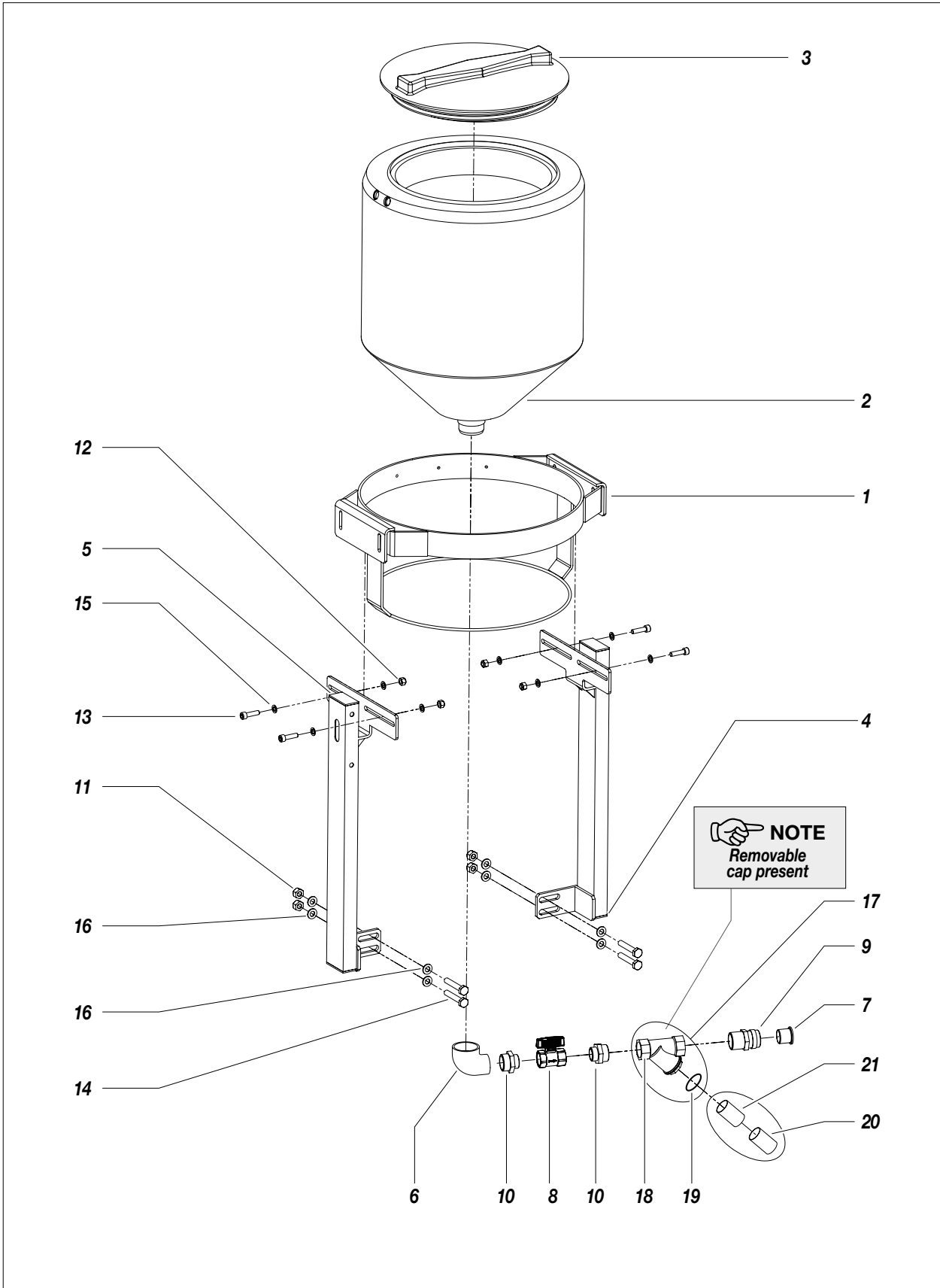

Pos.	Code	Description	Q.ty
1	LA18246	Support	1
2	LA18249	Tank 50 lt	1
3	LA18249/1	Cover tank 50 lt	1
4	LA18238	Right support tank 50 lt	1
5	LA18238/1	Left support tank 50 lt	1
6	LA20833R	90° elbow	1
7	LA96099R	Seal	1
8	LA20825R	Ball valve	1
9	Vedi kit LA40479	Intake hose connector	1
10	LA20817R	Adapter fitting	2
11	LA96080	Nut	4
12	Vedi kit LA3637/25	Nut	4

Pos.	Code	Description	Q.ty
13	Vedi kit LA901568/10	Screw	4
14	LA20560	Screw	4
15	Vedi kit LA32024/10	Washer	8
16	LA81033	Washer	8
17	LA200537/1	Y-fitting for filtration with gasket	1
18	LA200537	Y-fitting for filtration	1
19	LA200431	O-ring	1
20	LA200538	Coarse mesh filter	1
21	LA200539	Fine mesh filter	1

Intake hose connector Kit - Cod. LA40479		
Pos.	Description	Q.ty
7	Seal	1
9	Intake hose connector	1

Screw Kit - Cod. LA901568/10		
Pos.	Description	Q.ty
13	Screw	10

Nut Kit - Cod. LA3637/25		
Pos.	Description	Q.ty
12	Nut	25

Washer Kit - Cod. LA32024/10		
Pos.	Description	Q.ty
15	Washer	10

## Z SPEED POTENTIOMETER ASSEMBLY - LA200551

**WARNING:** Always indicate code and quantity for each part required.

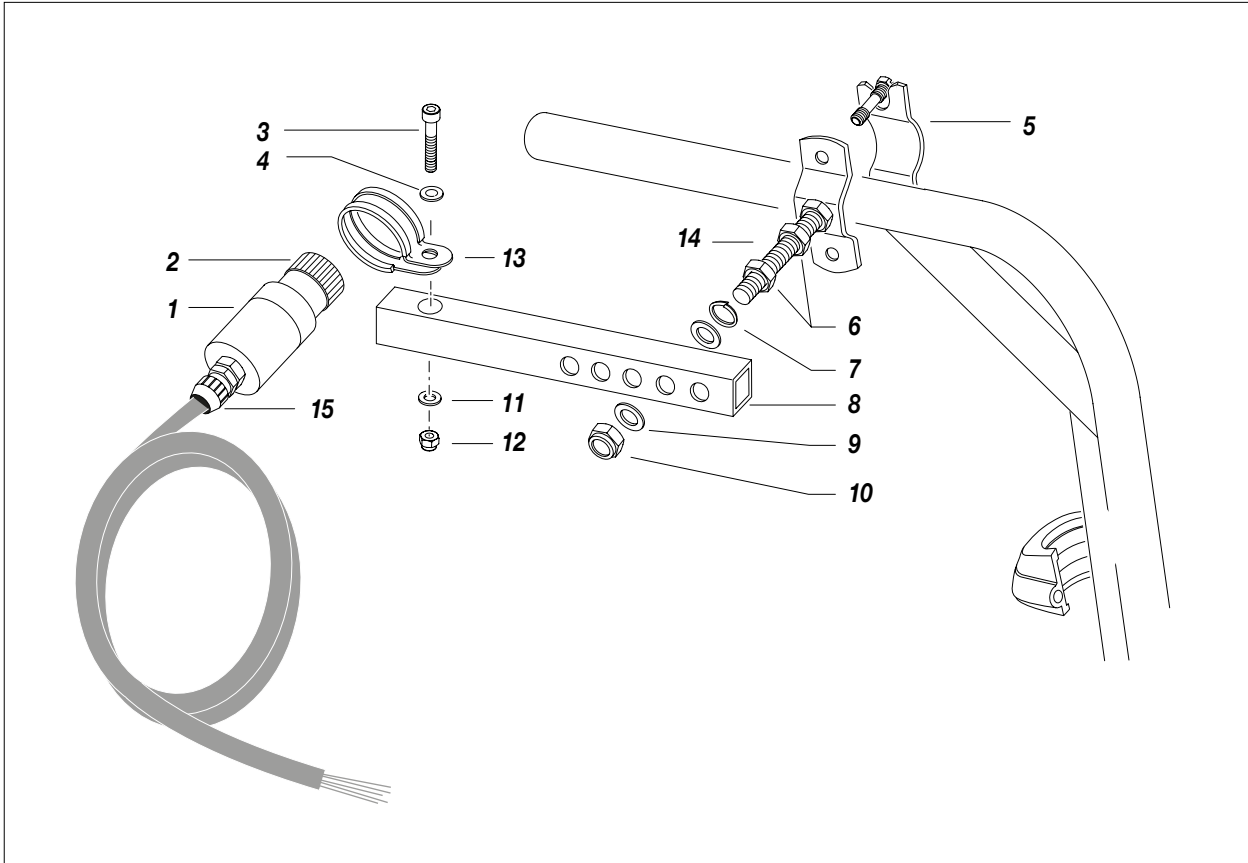

Pos.	Code	Description	Q.ty
	<b>LA200551</b>	<b>Speed potentiometer assembly</b>	<b>1</b>
1	LA4462	Potentiometer knob	1
2	LA4523	Screw M6x35	1
3	LA8037	Grower washer Ø6	1
4	LA54003	Hydraulic collar 1/2"	1
5	LA4515	Nut M8	1
6	LA52017	Grower washer Ø8	2
7	LA96030	Potentiometer support bracket	1

Pos.	Code	Description	Q.ty
8	LA4523/2	Washer Ø8	1
9	LA32024	Self-locking nut M8	2
10	LA3637	Washer Ø6	1
11	LA95063	Self blocking ring nut M6	1
12	LA8042	Rubber fairlead w1 Ø35	1
13	LA3070	Threaded rod M8 60mm	1
14	LA18391/1	Barra filettata M8 60mm	1
15	LA20450	Sleeve connector 1/4 Ø8	1

## AA HANDLEBAR CONTROLS

**WARNING:** Always indicate code and quantity for each part required.

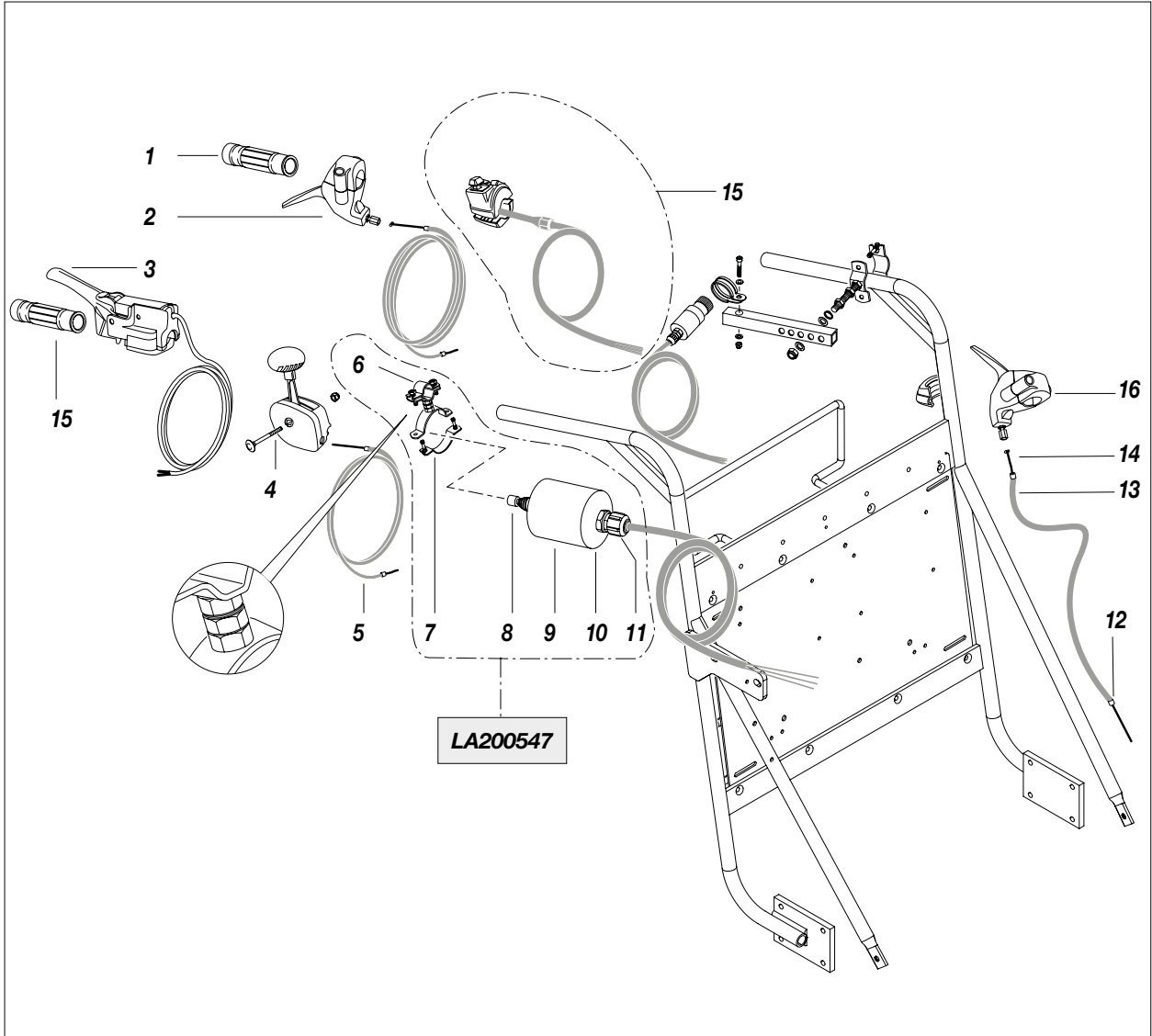

Pos.	Code	Description	Q.ty
1	LA4047	Liner knob	2
2	LA4464	Control lever	2
3	LA4046	Red gear lever	1
4	LA4048	Accelerator lever	1
5	LA4049	Ignition lever cable	1
6	LA4515	Collar GIA 1/2"	1
7	LA4517	Collare GIA 2"	1
8	LA4769	Cema selector	1
	LA4769/1	Selector contacts	2
9	LA4796	Selector box	1

Pos.	Code	Description	Q.ty
10	LA4797	Box cover	1
11	LA20450	Sleeve connector 1/4 Ø8	1
12	LA4253	Terminal clamp	1
13	LA4261	Sleeve 0.85 mt	1
14	LA4258	Tie rod wire	1
15	LA200545	Liner traction control	1
		Control cap Wires, protective tubing and plugs	1

## AB SOLENOID VALVE BOX - LA200596

**WARNING:** Always indicate code and quantity for each part required.

TABLE 1/2

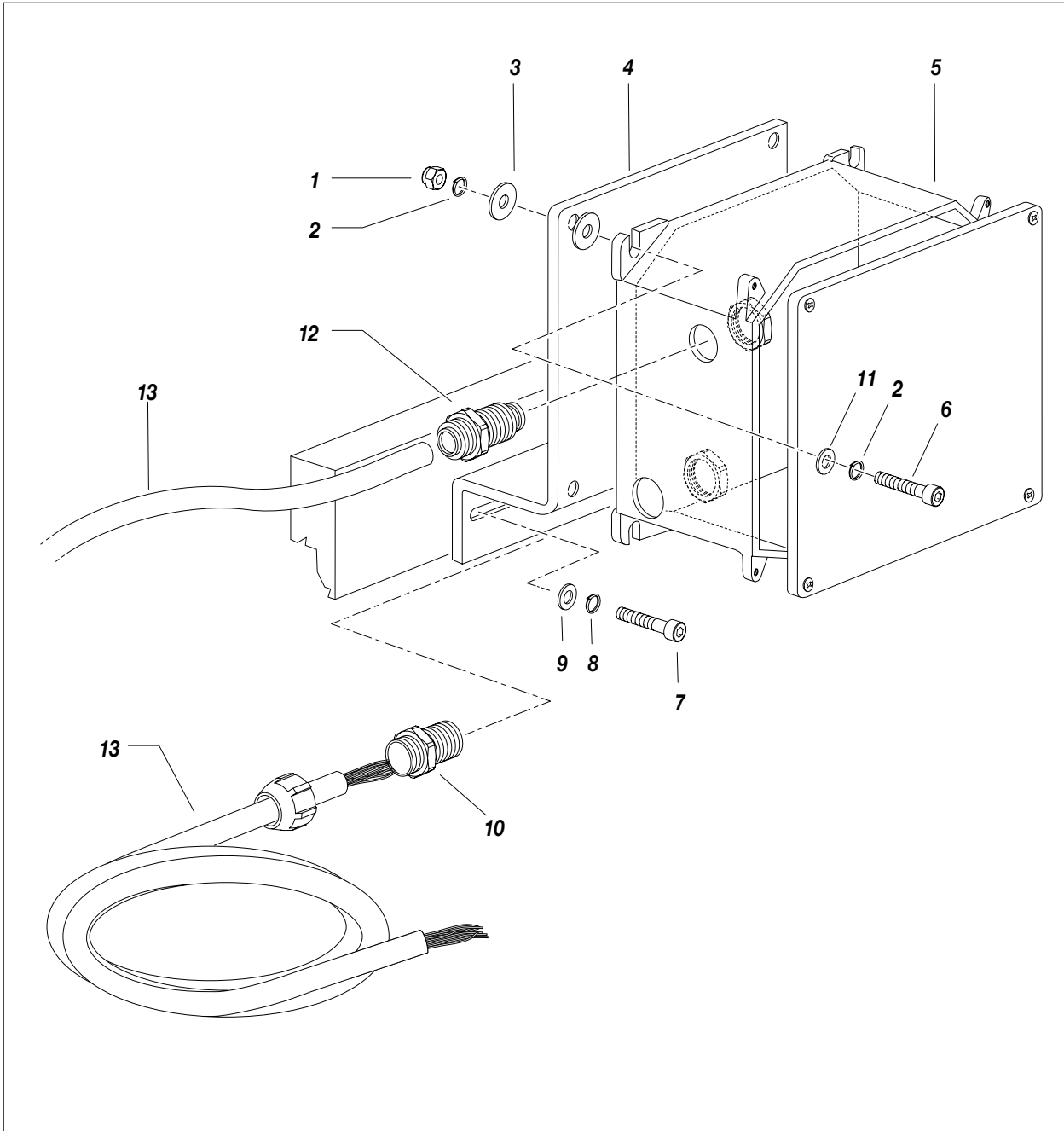

Pos.	Code	Description	Q.ty
	<b>LA200596</b>	<b>Solenoid valve box</b>	<b>1</b>
1	LA8042	Self blocking ring nut M6	4
2	LA95063	Washer Ø6	8
3	LA510068	Wide washer Ø6	8
4	LA4572	Box fixing bracket	1
5	LA4498	Box	1
6	LA8029	Screw M6x30	4

Pos.	Code	Description	Q.ty
7	LA96031	Screw M8x25	3
8	LA96030	Grower washer Ø8	3
9	LA 32024	Washer Ø8	3
10	LA24202	Sleeve fitting Ø12 3/8"	1
11	LA54003	Grower washer Ø6	4
12	LAZ00385	Cable gland Ø8-10	1
13	LA18170	Rilsan tube Ø10x8	2,00 mt

**WARNING:** Always indicate code and quantity for each part required.

TABLE 2/2

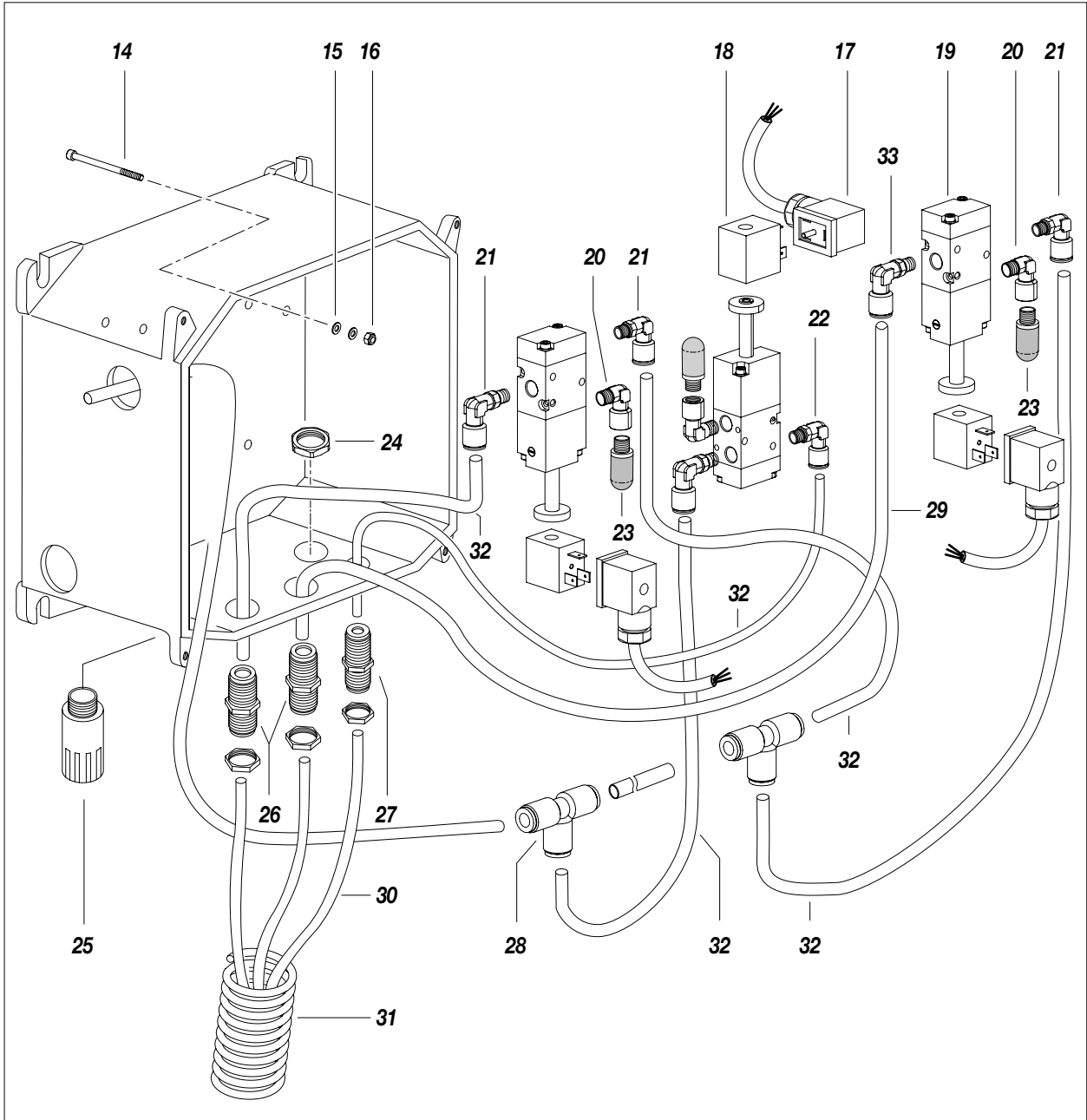

Pos.	Codice	Descrizione	Q.tà
14	LA11765	Screw M4x35	6
15	LA5339	Washer Ø4	12
16	LA4043	Self blocking ring nut M4	6
17	LA4760	Connector	3
18	LA4759	Coil	3
19	LA4753	Valve	3
20	LA3341	Elbow MF 1/8"	3
21	LA11797	Swivel elbow fitting 1/8" Ø8	5
22	LA11798	Swivel elbow fitting 1/8" Ø6	1
23	LA510423	Silencer 1/8"	3

Pos.	Codice	Descrizione	Q.tà
24	LA24103	Ring nut 3/8"	1
25	LA8405	Silencer 3/8"	1
26	LA19176	Cable gland Ø8	2
27	LA19167	Cable gland Ø6	1
28	LA510020	Quick coupling "T" Ø8	2
29	LA9784	Elastollan tube Ø6x4	0,25 mt
30	LA5668	Rilsan tube Ø6x4	1,30 mt
31	LA16211	Sleeve Ø20	0,70 mt
32	LA200591	Elastollan tube Ø8	1 mt
33	LA11798	Raccordo gomito girevole Ø6x1/8"	1

## AC OPERATOR FOOTBOARD - LA26000

**WARNING:** Always indicate code and quantity for each part required.

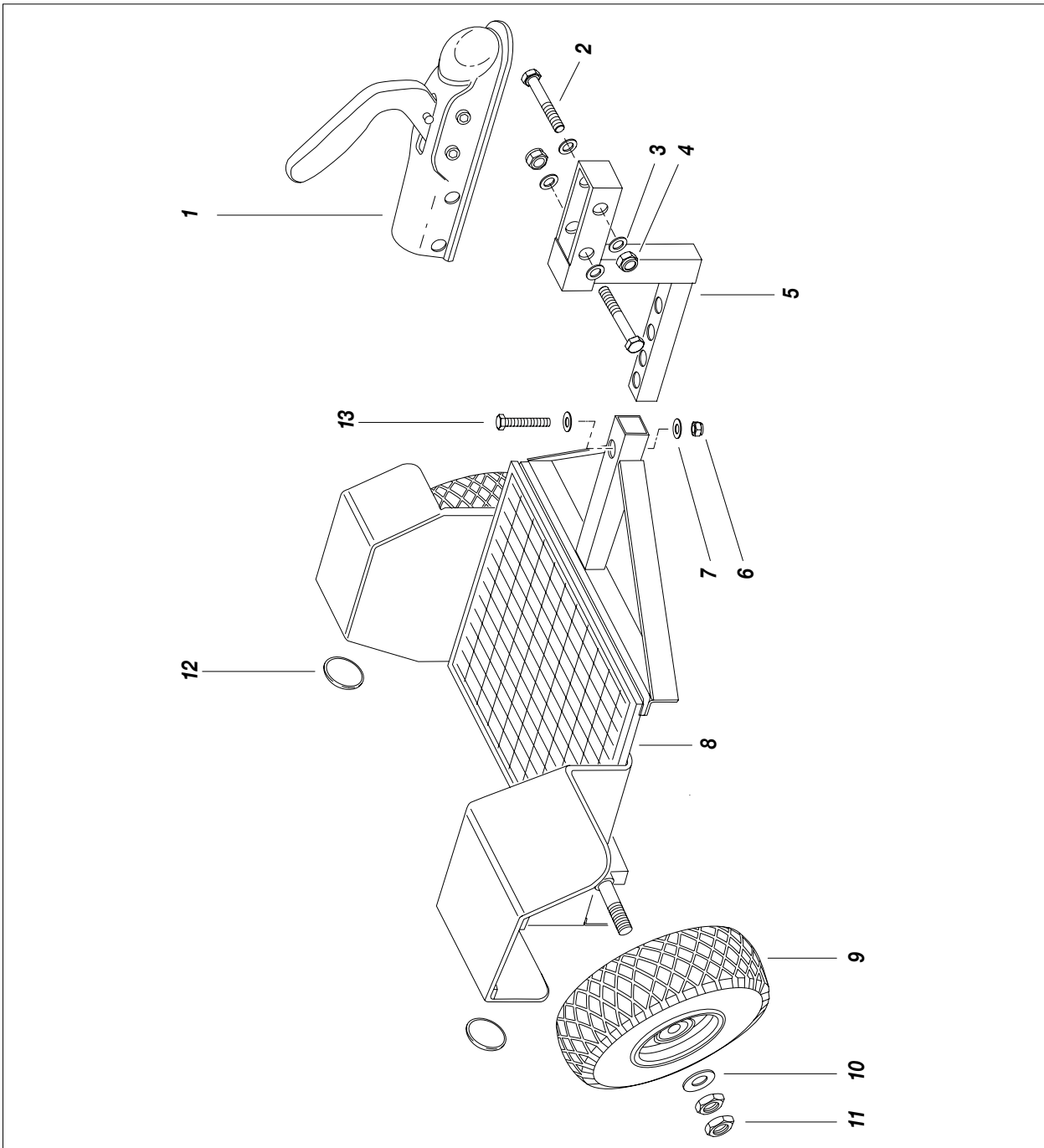

Pos.	Code	Description	Q.ty
1	LA4728	Towing hitch head	1
2	LA20539	Screw M10x75	2
3	LA81033	Washer Ø10	4
4	LA96080	Self locking ring nut M10	2
5	LA26004	Footboard-fork connection	1
6	LA3637	Self locking ring nut M8	1
7	LA32024/1	Wide washer Ø8	2

Pos.	Code	Description	Q.ty
8	LA26002	Liner platform base	1
9	LA26003	Platform wheel liner	2
10	LA95110	Washer Ø20	2
11	LA95007	Nut M20x2,5	4
12	LA26050	Adhesive catarifrangant Ø60	2
13	LA4305	Screw M10x50	1

## AD REVERSE BUZZER

**WARNING:** Always indicate code and quantity for each part required.

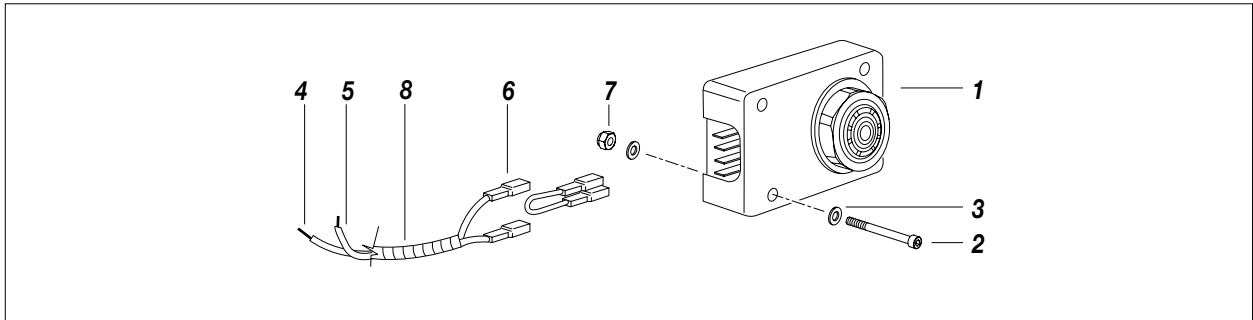

Pos.	Code	Description	Q.ty
	<b>LA200550</b>	<b>Cicalino retromarcia</b>	<b>1</b>
1	LA20023	Hooter buzzer 10V/100V	1
2	LA16310	Screw M4x45	2
3	LA5339	Washer Ø4	4
4	LA10401	Cable 1x1 black	50cm

Pos.	Code	Description	Q.ty
5	LA10403	Cable 1x1 mm <sup>2</sup> red	50cm
6	LA10302	Faston female 13M00191 1,5mm	2
7	LA4043	Self locking ring nut M4	2
8	LA200239	Spiral cable	40cm

# AE FILTER GROUP - LA200372R

**WARNING:** Always indicate code and quantity for each part required.

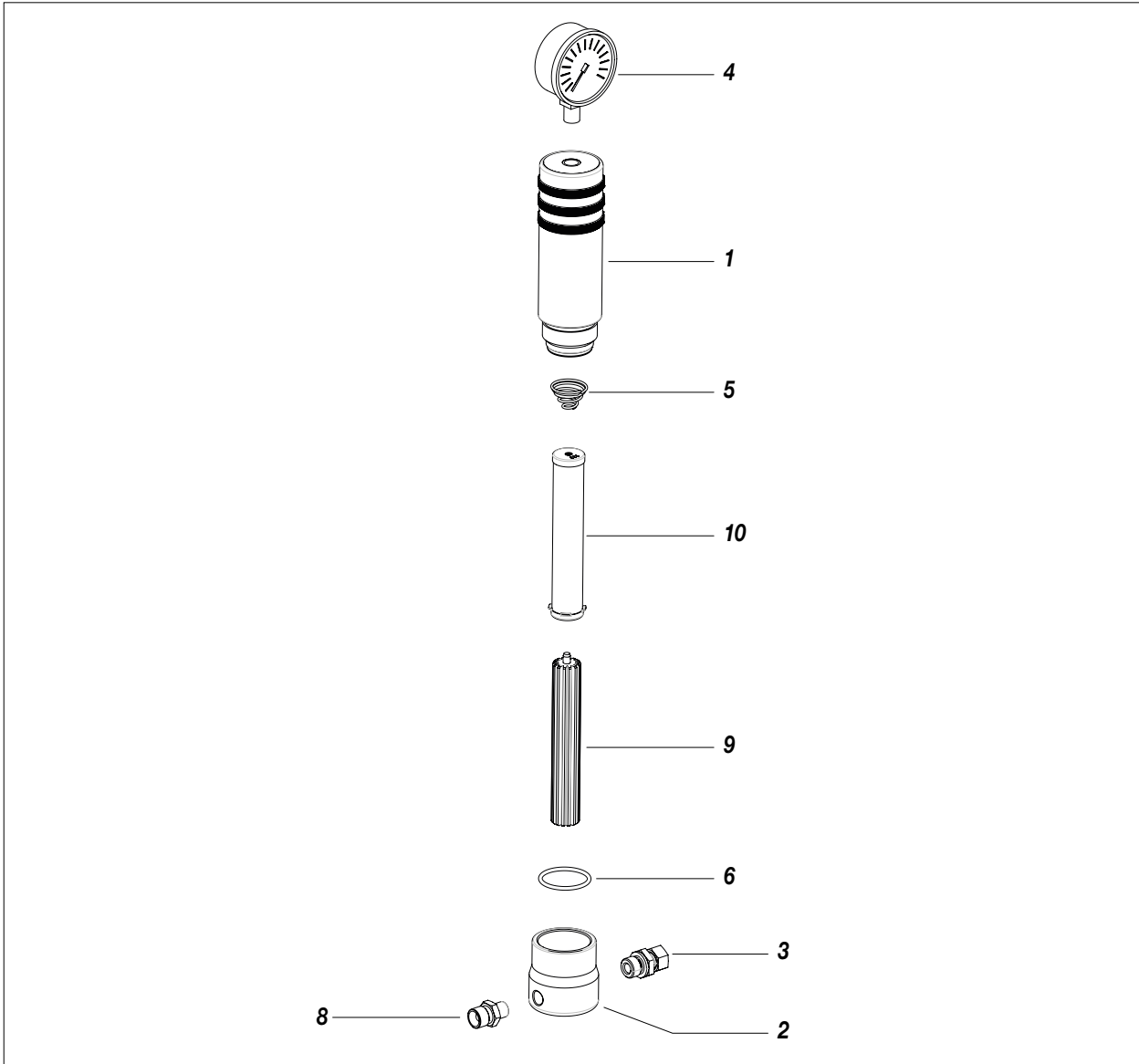

Pos.	Code	Description	Q.ty
	<b>LA200372R</b>	<b>Filter assembly</b>	1
1	See kit LA40418	Filter tank	1
2	Vedi kit LA40516	Filter base	1
3	LA3279	Nose union	1
4	LA40200	Manometer	1
5	See kit LA96202/5	Spring	1
6	LA96203R	O-Ring	1
7	-	-	-
8	LA96206	Nipple	1
9	LA96207R	Sieve holder	1
10	LA95220	Filter sieve 100 mesh	1
11	-	-	-
12	-	-	-

Filter tank Kit - Cod. LA40418		
Pos.	Description	Q.ty
1	Filter tank	1
5	Spring	1
6	O-Ring	1

Springs Kit - Cod. LA96202/5		
Pos.	Description	Q.ty
5	Spring	5

Filter base Kit - Cod. LA40516		
Pos.	Description	Q.ty
2	Filter base	1
6	O-Ring	1

**Intentionally blank page**

# AF COMPLETE SHORT PUMPING ELEMENT

**WARNING:** Contact the manufacturer always indicating code and quantity for each part required.

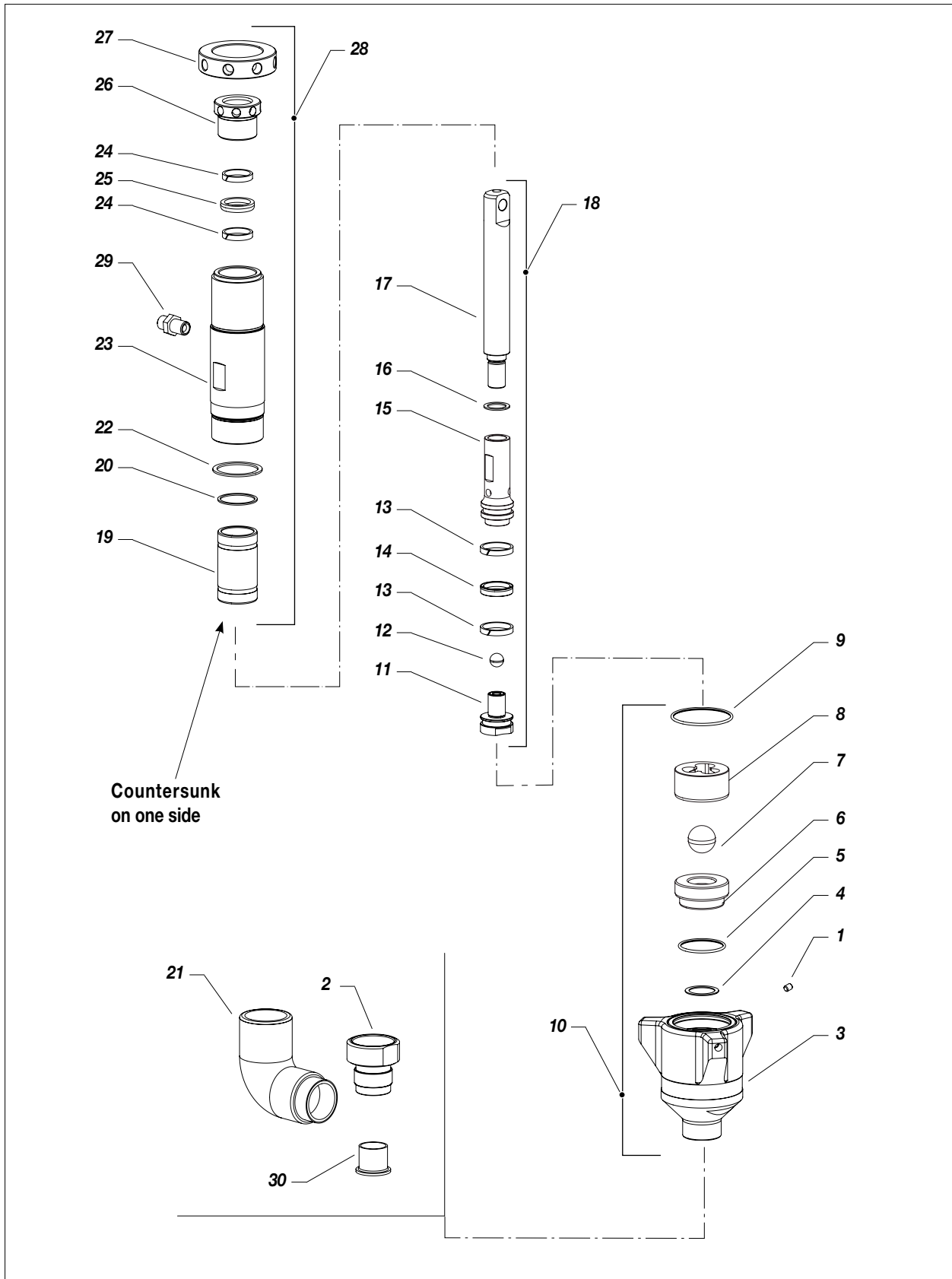

Pos.	Code	Description	Q.ty
-	-	<b>Complete short pumping element heavy products</b>	1
1	LA81106	Dowel	3
2	LA19295	Suction pipefitting	1
3	LA20130	Assembled valve	1
4	LA19296	Sealing	1
5	LA20131	OR	1
6	LA20143	Ball housing assembly	1
7	LA20148	Ball	1
8	LA19297	Ball guide	1
9	LA20132/5	Kit 5 OR	5
10	LA20133	Heavy products footvalve unit assembly	1
10	LA20145	Standard products footvalve unit assembly	1
11	LA20134	Stem valve assembly	1
12	LA16120R	Ball	1
13	LA20135	Lower seal bands	2
14	LA20136	Lower gasket	1

Pos.	Code	Description	Q.ty
15	LA20116	Short stem	1
16	LA20106	Sealing	1
17	LA20107	Upper stem	1
18	LA20137	Heavy products stem assembly	1
18	LA20146	Standard products stem assembly	1
19	LA20108	Sleeve	1
20	LA20109	Sleeve-cylinder seal	1
21	LA20172	90° bend	1
22	LA20111	Sealing	1
23	LA20112	Upper pump unit casing	1
24	LA20138	Upper guide band	24
25	LA20139	Upper gasket	1
26	LA20113	Ring nut	1
27	LA20114	Tightening ring nut	1
28	LA20140	Heavy products jacket assembly	1
28	LA20147	Standard products jacket assembly	1
29	LA34109	Adapter	1
30	LA96099R	Seal sleeve	1

## AG REDUCTION UNIT

**WARNING:** Contact the manufacturer always indicating code and quantity for each part required.

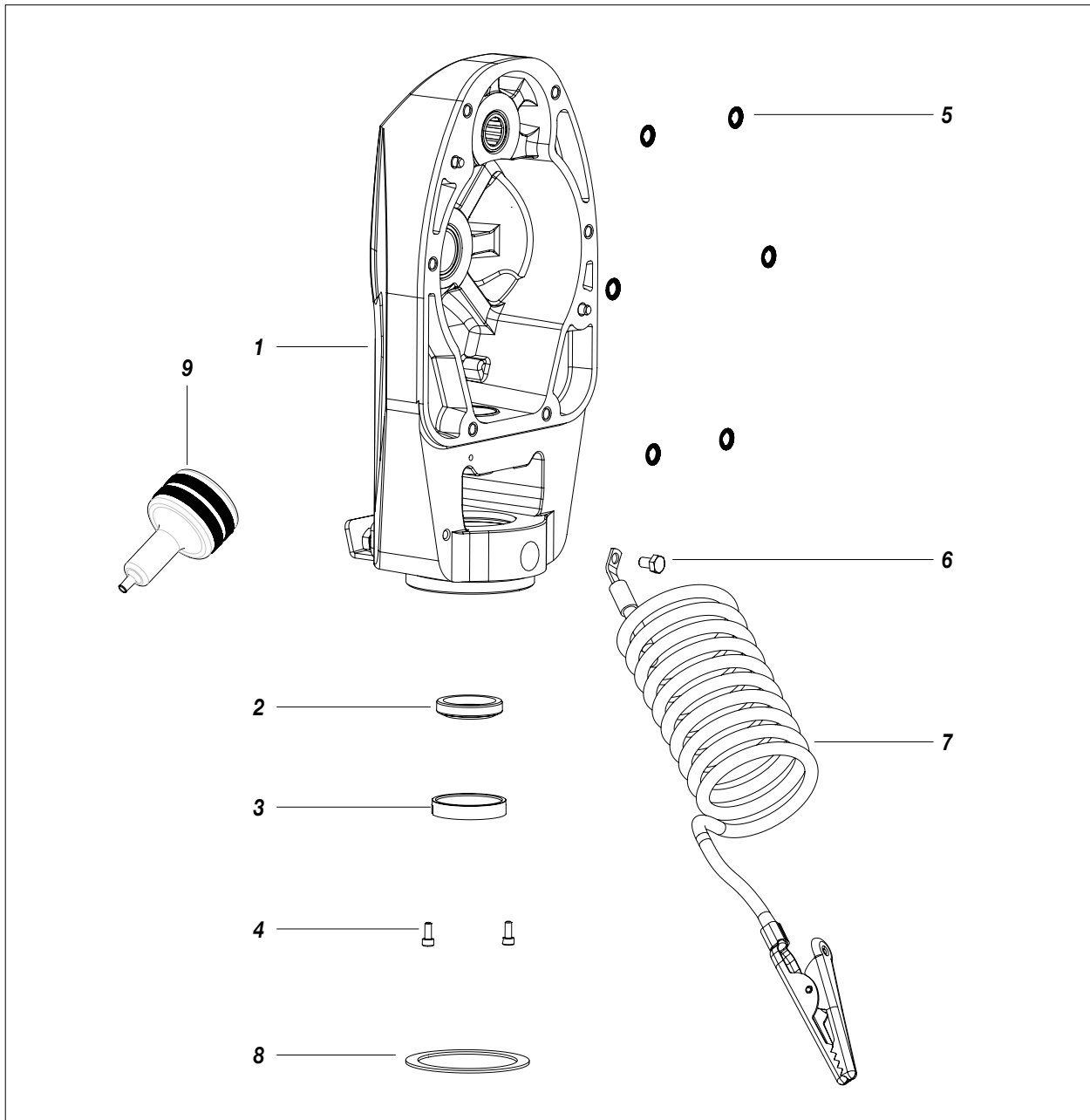

Pos.	Code	Description	Q.ty
1	See Kit LA20267	Cover Assembly	1
2	-	Scraper	1
3	-	Fixing ring	1
4	-	Screw	2
5	-	Schnor washer	6
6	-	Srew	1
7	LA5010	Grounding cable	1
8	LA20285	Locking ring	1
9	LA20213R	Threaded Pin	1

**WARNING:** Contact the manufacturer always indicating code and quantity for each part required.

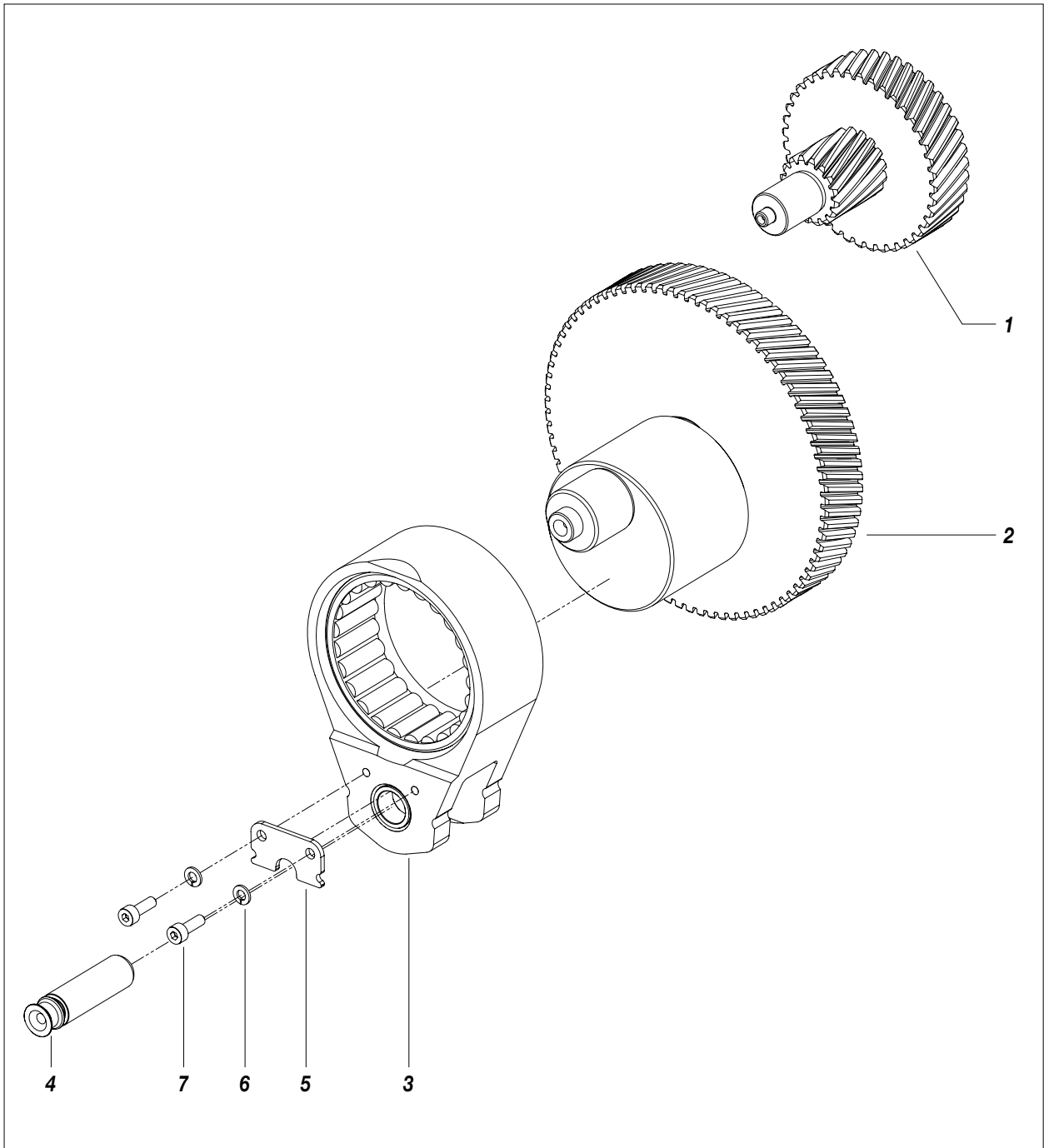

Pos.	Code	Description	Q.ty
1	LA20258R	Toothed driving assembly Thor 28	1
2	LA20259R	Cam assembly Thor 28	1
3	LA20262R	Complete connecting rod Thor	1
4	Vedi kit LA40495	Pump unit pivot Thor 28	1
5	LA30213	Pin locking plate Thor 28	1
6	LA32043	Grower washer	2
7	LA5338	TCE screw	2

Pump unit pivot Kit - Cod. LA40495		
Pos.	Description	Q.ty
4	Pump unit pivot Thor 28	1
5	Pin locking plate Thor 28	1
6	Grower washer	2
7	TCE screw	2

# AF AT250 HIGH PRESSURE SPRAY GUN

**WARNING:** Contact the manufacturer always indicating code and quantity for each part required.

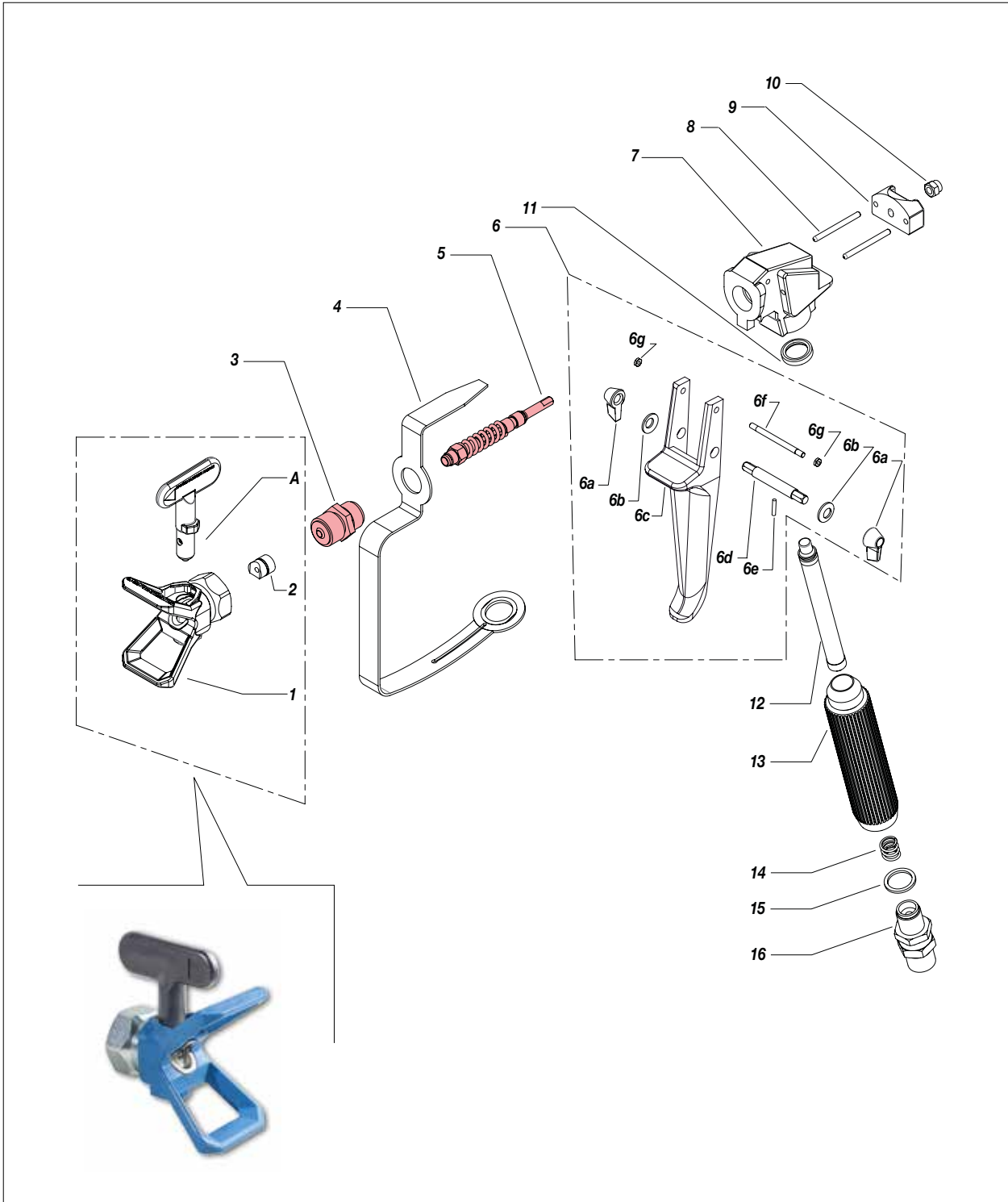

Pos.	Code	Description	Q.ty
A	Vedi tab.*	Nozzle Super Fast Clean	1
1	LA18270	Body Super Fast Clean	1
	LA18290	Body Super Fast Clean America	1
2	LA18280	SFC Gasket	1
3	LA11004R	Sleeve	1
	LA11217	Sleeve - America	1
4	LA11006	Safety for hand	1
5	Vedi kit LA40005 o LA40006	Complete linkage	1
6	LA11008	Gun trigger	1
6a	-	Safety lever	2
6b	-	Brake washer	2
6c	-	Trigger	1
6d	-	Pin	1
6e	-	Spinnet	1
6f	-	Pin	1

Pos.	Code	Description	Q.ty
6g	-	Self-locking nut	2
7	LA11206	Gun body	1
8	LA11207	Spinnet	2
9	Vedi kit LA40462	Plate	1
10	LA11209	Nut	1
11	LA11020	Gasket	1
12	LA11037	Yellow Gun Filter 100 Mesh	1
	LA11038	White Gun Filter 60 Mesh	1
	LA11019	Red Gun Filter 200 Mesh	1
13	LA11018R	Handgrip	1
14	LA11017R	Spring	1
15	LA32010	Copper gasket	1
16	LA11015	Swivelling joint M16x1,5	1
	LA10152R	Articulated joints 1/4 NPSM	1
	LA10155R	Swivelling joint 1/4" GAS	1

Kit code	Position	Description
LA40005	3, 5	Kit AT250
LA40006	3, 5	Kit AT250 America
LA40462	8, 9, 10	Kit piastrina

*Cod. nozzle-angle	Ø inch	Ø mm	Prod. type	Filter recom.
LASFC07-20	0,007"	0,18	Clear and pigmented coats, thin enamels	Red 200 M
LASFC07-40				
LASFC09-20	0,009"	0,23	Nitro, synthetic and polyurethane paints	Yellow 100 M
LASFC09-40				
LASFC11-20	0,011"	0,28	Antitrust	
LASFC11-40				
LASFC13-20	0,013"	0,33	Antitrust	
LASFC13-40				
LASFC13-60	0,015"	0,38	Antitrust	
LASFC15-20				
LASFC15-40	0,017"	0,43	Antitrust	
LASFC15-60				
LASFC17-20	0,019"	0,48	Coatings, zinc inorganic water paints	
LASFC17-40				
LASFC17-60	0,021"	0,53	Coatings, zinc inorganic water paints	
LASFC19-20				
LASFC19-40	0,023"	0,58	Coatings, zinc inorganic water paints	
LASFC19-60				
LASFC21-20	0,025"	0,63	Coatings, zinc inorganic water paints	
LASFC21-40				
LASFC21-60	0,027"	0,68	Coatings, zinc inorganic water paints	
LASFC23-20				
LASFC23-40	0,029"	0,74	Coatings, zinc inorganic water paints	
LASFC23-60				
LASFC25-20	0,031"	0,79	Thixotropic, stucco spray, high solids paints with glue, fillers	
LASFC25-40				
LASFC25-60	0,033"	0,83	Thixotropic, stucco spray, high solids paints with glue, fillers	
LASFC27-20				
LASFC27-40	0,035"	0,89	Thixotropic, stucco spray, high solids paints with glue, fillers	
LASFC27-60				
LASFC27-80	0,037"	0,94	Thixotropic, stucco spray, high solids paints with glue, fillers	
LASFC29-20				
LASFC29-40	0,039"	1,00	Thixotropic, stucco spray, high solids paints with glue, fillers	
LASFC29-60				
LASFC29-80	0,041"	1,05	Thixotropic, stucco spray, high solids paints with glue, fillers	
LASFC31-40				
LASFC31-60	0,043"	1,10	Thixotropic, stucco spray, high solids paints with glue, fillers	
LASFC31-80				
LASFC33-40	0,045"	0,15	Thixotropic, stucco spray, high solids paints with glue, fillers	
LASFC33-60				
LASFC33-80	0,047"	1,20	Thixotropic, stucco spray, high solids paints with glue, fillers	
LASFC35-40				
LASFC37-40	0,051"	1,30	Thixotropic, stucco spray, high solids paints with glue, fillers	
LASFC39-40				
LASFC39-60				
LASFC39-80				
LASFC41-40				
LASFC43-40				
LASFC43-60				
LASFC43-80				
LASFC45-60				
LASFC47-60				
LASFC51-60				
LASFC51-80				

# AI LA95 SPRAY GUN EXPLODED VIEW LINER - LA11700/4

**WARNING:** Contact the manufacturer always indicating code and quantity for each part required.

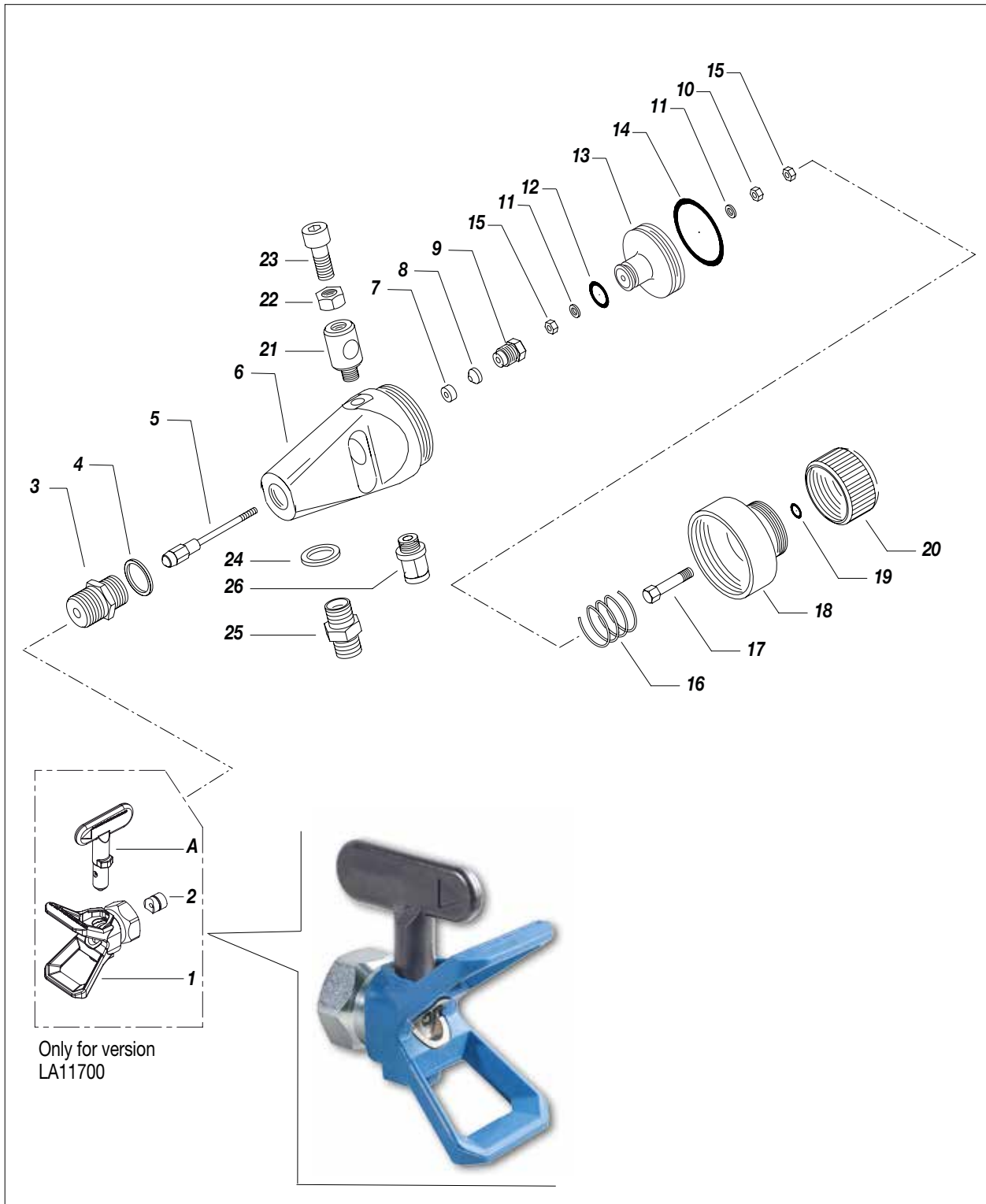

Pos.	Codice	Descrizione
A	See table*	Nozzle Super Fast Clean
1	LA18270	Body Super Fast Clean
2	LA18280	Gasket Super Fast Clean
3	LA11004	Sleeve
	LA23337	Flat sleeve (code LA11700/2)
	LA23336	Flared sleeve (code LA11700/3)
4	LA33007	Washer
5	LA11705	Punch
6	LA11711	Gun body
7	LA11712	Gaskets stuffing ring
8	LA11114	Gasket
9	LA11713	Gaskets stuffing screw
10	LA90034	M3 nut
11	LA11714	Washer
12	LA32015/3	O-ring
13	LA11721	Piston
14	LA11105	O-ring
15	LA11027	Self-blocking nut
16	LA11108	Spring
17	LA11715	Screw
18	LA11716	Back tap
19	LA33013/7	O-ring
20	LA11717	Adjusting knob
21	LA11718	Female coupling
	LA11720	Male coupling
22	LA52017	Nut
23	LA34008	Screw
24	LA33012	Washer
25	LA3199	Nipple
26	LA11719	Cylindric fitting

*Code-nozzle angle	Ø inch	Ø mm	Product type	Filter recom.
LASFC07-20 LASFC07-40	0,007"	0,18	Transp. and pigmented paints, thin enamels	Red 200 M
LASFC09-20 LASFC09-40	0,009"	0,23		
LASFC11-20 LASFC11-40	0,011"	0,28	Nitro, synthetic and polyurethane paints	Yellow 100 M
LASFC13-20 LASFC13-40 LASFC13-60	0,013"	0,33		
LASFC15-20 LASFC15-40 LASFC15-60	0,015"	0,38	Antitrust	
LASFC17-20 LASFC17-40 LASFC17-60	0,017"	0,43		
LASFC19-20 LASFC19-40 LASFC19-60	0,019"	0,48		
LASFC21-20 LASFC21-40 LASFC21-60	0,021"	0,53	Primers, zinc inorganic, water paints	
LASFC23-20 LASFC23-40 LASFC23-60	0,023"	0,58		
LASFC25-20 LASFC25-40 LASFC25-60	0,025"	0,63	Thixotropic, stucco spray, high solid, paints with glue, fillers	White 60 M
LASFC27-20 LASFC27-40 LASFC27-60 LASFC27-80	0,027"	0,68		
LASFC29-20 LASFC29-40 LASFC29-60 LASFC29-80	0,029"	0,74		
LASFC31-40 LASFC31-60 LASFC31-80	0,031"	0,79		
LASFC33-40 LASFC33-60 LASFC33-80	0,033"	0,83		
LASFC35-40 LASFC37-40	0,035" 0,037"	0,89 0,94		
LASFC39-40 LASFC39-60 LASFC39-80	0,039"	1,00		
LASFC41-40 LASFC43-40 LASFC43-60 LASFC43-80	0,041" 0,043"	1,05 1,10	wwGreen 30 M	
LASFC45-60 LASFC47-60	0,045" 0,047"	0,15 1,20		
LASFC51-60 LASFC51-80	0,051"	1,30		

# AJ FLOW COMPENSATOR

**WARNING:** Contact the manufacturer always indicating code and quantity for each part required.

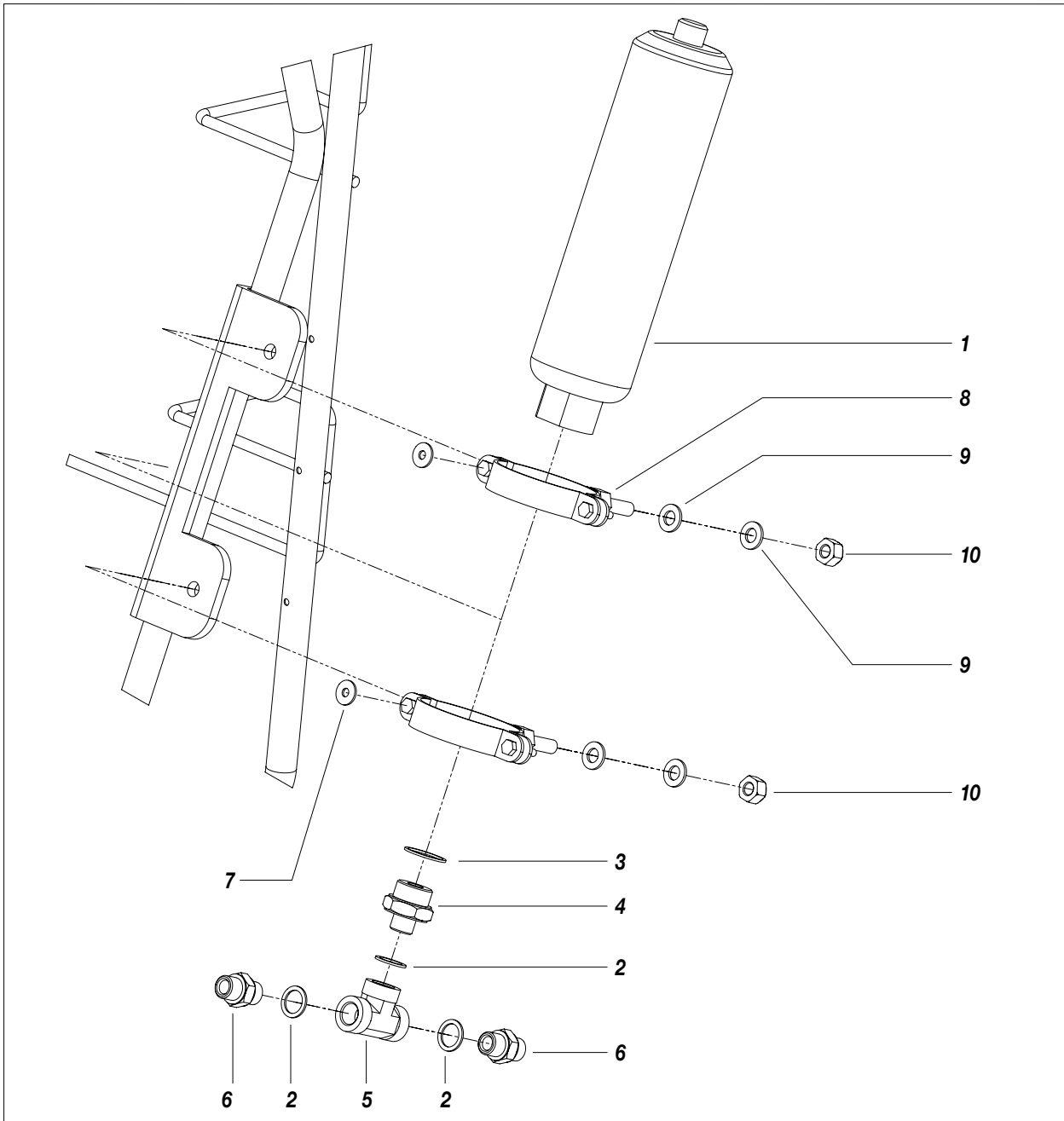

Pos.	Code	Description	Q.ty
	xxxx	Flow compensator	1
1	See kit LA200374	Flow compensator L0.5 MAX 330 Bar	1
2	See kit LA33010/10	Washer	3
3	LA91622R	Gasket	1
4	LA200377	Union	1
5	LA8078/1	T fitting	1
6	LA34109R	Union	2
7	LA510068	Washer	2
8	LA4522	Collar	2

Pos.	Code	Description	Q.ty
9	LA81033	Washer	4
10	LA96080	Nut	2

**Flow compensator Kit L0.5 MAX 330 Bar - Cod. LA200374**

Pos.	Description	Q.tà
1	Flow compensator	1
3	Gasket	1

**Washer Kit - Cod. LA33010/10**

Pos.	Description	Q.tà
2	Washer	10

## AK BATTERY GROUP

**WARNING:** Contact the manufacturer always indicating code and quantity for each part required.

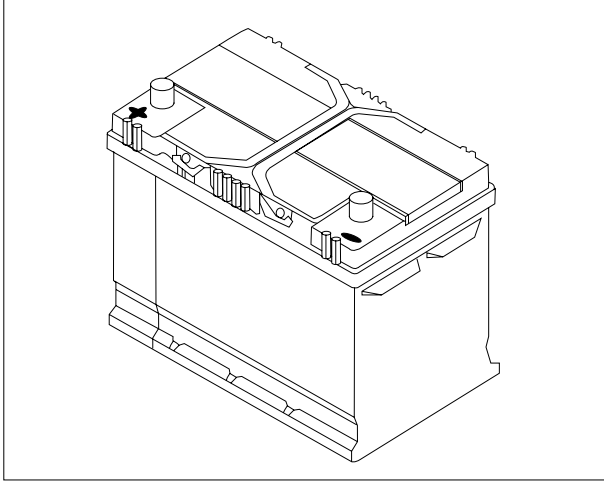

Code	Description
LA4010/1	Battery

## AL BOARD V.2.50

**WARNING:** Contact the manufacturer always indicating code and quantity for each part required.



Description	Q.ty
Electronic board V.2.50	1

## **AM** INFORMATION FOR THE CORRECT CHOICE OF THE AIRLESS ROAD SIGS PAINT TO USE

In order to facilitate the perfect operation of line striper machines, it is good to pay attention to the choice of sheet paint. When purchasing the product, check together with the retailer of the paints, the information in this information sheet.

### TECHNICAL DATA PAINT AND ITS REQUIREMENTS:

- Always make sure that the paint is airless, microfiltered, and that it is absolutely. **MAXIMUM PARTICLE SIZE MUST BE 120 MICRONS**
- Dilute the paint appropriately, with water or solvent depending on the type. Follow the manufacturer's directions, while still considering that you get a good spraying result **FORD4 CUP VALUES BETWEEN 50 AND 90 SECONDS.**
- Check that the paint appropriate to the current season is used (Some paints have summer and winter solutions).

### INDICATIONS FOR THE USE OF PAINT:

- The paint has a deadline. Make sure that it is still usable and that the date indicated has not passed.
- Carefully mix the product before use, especially when stored for a long time, as the same tends to separate. For this purpose use a mixing drill with appropriate whisk. **MANUAL MIXING WITH TOOLS OR BARS IS NOT ENOUGH!**



**Absolutely avoid using pieces of wood or dirty objects that could release impurities that would clog the pump.**

- Avoid making water products come into contact with solvent products. To this end, if you change the type of product, first pass into the machine the basic component of what you will use (so, if we go to use a product to water, we will have to circulate in the pump, pipes and water guns before the paint; while if we go to use a solvent product we will have to circulate in the pump pipes and guns the appropriate solvent before the paint).
- At the end of the work, thoroughly clean the pump, pipes, filters and guns.
- It is not recommended to use paints that have been open for a long time and have remained unused, as they could create lumps that would clog the nozzle or otherwise bring a not perfect tracing result.



## CE DECLARATION OF CONFORMITY



### Company



**LARIUS srl**  
Via Antonio Stoppani 21 - 23801 Calolziocorte (LC) ITALY  
**Tel:** +39 0341 621152  
**Fax:** +39 0341 621243  
**E-mail:** larius@larius.com

Declares under his owns responsibility that the product:

### Everest TH Liner Horizontal Street Marking

complies with the directives:

- EC Directive 2006/42 Machinery Directive
- EU Directive 2014/30 Electromagnetic Compatibility (EMC)
- EU Directive 2014/35 Low Voltage (LVD)

furthermore to the  
harmonized standards:

- UNI EN ISO 12100-1/-2  
Machinery safety, basic concepts, general principles of design. Basic terminology, methodology. Technical principles.

This declaration relates exclusively to the product in the state in which it was placed on the market, and excludes components or modifications which are added or carried out subsequently by end user.

*Signature*

**Pierangelo Castagna**  
Managing Director

Calolziocorte, 12 April 2024  
Location / Date



**SAMOA INDUSTRIAL, S.A. - HEADQUARTERS  
SPAIN AND EXPORT MARKETS**

POL. IND. PORCEYO, I-14 - CAMINO DEL FONTÁN, 831  
E-33392 GIJÓN (ASTURIAS), SPAIN  
TEL.: +34 985 381 488 - FAX: + 34 985 147 213

**SAMOA S.A.R.L.  
FRANCE**

P.A.E.I. DU GIESSEN  
3, RUE DE BRISCHBACH  
67750 SCHERWILLER, FRANCE  
TEL.: +33 3 88 82 79 62 - FAX: +33 3 88 82 77 88

**SAMOA ITALIA - LARIUS  
ITALY**

VIA ANTONIO STOPPANI,21  
23801 CALOLZIOCORTE (LC) ITALY  
Tel.: +39 0341 621152 - Fax: + 39 0341 621242

**SAMOA FLOWTECH GMBH**

GERMANY, AUSTRIA, SWITZERLAND, THE NETHERLANDS AND GREECE  
AM OBEREICHHOLZ 4  
D - 97828 MARKTHEIDENFELD, GERMANY  
TEL.: +49 9391 9826 0 - FAX: +49 9391 98 26 50

**SAMOA LTD.**

**UNITED KINGDOM AND REP. OF IRELAND**

ASTURIAS HOUSE - BARRS FOLD ROAD  
WINGATES INDUSTRIAL PARK  
WESTHOUGHTON, BL5 3XP, UK  
TEL.: +44 1942 850600 - FAX: +44 1942 812160

**SAMOA CORPORATION**

USA AND CANADA  
90 MONTICELLO ROAD  
WEAVERVILLE, NC 28787, USA  
TEL. +1 (828) 645-2290 - FAX: +1 (828) 658 0840



©Copyright, SAMOA INDUSTRIAL, S.A.  
SAMOA Industrial, S.A. is an ISO 9001, ISO 14001 and ISO 45001 certified company.

**»» Contact us today!**

Visit [www.samoaindustrial.com](http://www.samoaindustrial.com) for more information.

OPERATING AND MAINTENAINCE MANUAL AVAILABLE IN:		
	IT	<a href="https://www.larius.com/wp-content/uploads/EVERESTLINER_I.pdf">https://www.larius.com/wp-content/uploads/EVERESTLINER_I.pdf</a>
	EN	<a href="https://www.larius.com/wp-content/uploads/EVERESTLINER_GB.pdf">https://www.larius.com/wp-content/uploads/EVERESTLINER_GB.pdf</a>
	DE	<a href="https://www.larius.com/wp-content/uploads/EVERESTLINER_D.pdf">https://www.larius.com/wp-content/uploads/EVERESTLINER_D.pdf</a>
	FR	<a href="https://www.larius.com/wp-content/uploads/EVERESTLINER_D.pdf">https://www.larius.com/wp-content/uploads/EVERESTLINER_D.pdf</a>
	ES	<a href="https://www.larius.com/wp-content/uploads/EVERESTLINER_SP.pdf">https://www.larius.com/wp-content/uploads/EVERESTLINER_SP.pdf</a>
	PL	<a href="https://www.larius.com/wp-content/uploads/EVERESTLINER_PL.pdf">https://www.larius.com/wp-content/uploads/EVERESTLINER_PL.pdf</a>