

[www.larius.com](http://www.larius.com)

# ECO K21

Street marking with battery



IT [https://www.larius.com/wp-content/uploads/ECO\\_K21\\_I.pdf](https://www.larius.com/wp-content/uploads/ECO_K21_I.pdf)

EN [https://www.larius.com/wp-content/uploads/ECO\\_K21\\_UK.pdf](https://www.larius.com/wp-content/uploads/ECO_K21_UK.pdf)

**This manual is to be considered as an English language translation of the original manual in Italian. The manufacturer shall bear no responsibility for any damages or inconveniences that may arise due to the incorrect translation of the instructions contained within the original manual in Italian.**

**Due to a constant product improvement programme, the factory reserves the right to modify technical details mentioned in this manual without prior notice.**

# ECO K21

Street marking with battery

## INDEX




















<b>A</b>	WARNINGS .....	p. 2
<b>B</b>	WORKING PRINCIPLE .....	p. 3
<b>C</b>	TECHNICAL DATA .....	p. 4
<b>D</b>	DESCRIPTION OF THE EQUIPMENT .....	p. 6
<b>E</b>	CONTROLS DESCRIPTION .....	p. 8
<b>F</b>	PANEL DESCRIPTION.....	p. 9
<b>G</b>	TRANSPORT AND UNPACKING.....	p. 9
<b>H</b>	CONDITIONS OF GUARANTEE .....	p.10
<b>I</b>	SAFETY RULES.....	p.10
<b>J</b>	TUBES CONNECTION .....	p.11
<b>K</b>	WASHING OF THE NEW EQUIPMENT .....	p.14
<b>L</b>	PRODUCT PREPARATION .....	P.15
<b>M</b>	GUN ASSEMBLY AND REGULATIONS.....	P.16
<b>N</b>	WORKING .....	P.18
<b>O</b>	CLEANING AT THE END OF THE WORK.....	P.19
<b>P</b>	GENERAL MAINTENAINCE.....	P.20
<b>Q</b>	BATTERY CHARGE .....	P.20
<b>R</b>	ROUTINE MAINTENAINCE .....	P.21
<b>S</b>	CORRECT PROCEDURE OF DECOMPRESSION .....	P.22
<b>T</b>	REPLACEMENT OF THE PUMPING GROUP'S GASKETS.....	P.23
<b>U</b>	PROBLEMS AND SOLUTIONS .....	P.32
	<b>SPARE PARTS</b>	
<b>V</b>	COMPLETE PUMPING GROUP .....	P.34
<b>W</b>	COMPLETE STEERING UNIT.....	P.37
<b>X</b>	COMPLETE 50L TANK .....	P.38
<b>Y</b>	FLOW COMPENSATOR .....	P.39
<b>Z</b>	COMPLETE RECIRCULATING GROUP .....	P.40
<b>AA</b>	RECIRCULATING-SAFETY VALVE GROUP .....	P.41
	DECLARATION OF CONFORMITY .....	p.43

**WE ADVISE THE USE OF THIS EQUIPMENT ONLY BY PROFESSIONAL OPERATORS.  
 ONLY USE THIS MACHINE FOR USAGE SPECIFICALLY MENTIONED IN THIS MANUAL.**

Thank you for choosing a **SAMOA** product.  
 As well as the product purchased, you will receive a range of support services  
 enabling you to achieve the results desired, quickly and professionally.

## A WARNINGS

The table below provides the meaning of the symbols used in this manual in relation to using, earthing, operating, maintaining, and repairing of this equipment.

	<ul style="list-style-type: none"> <li>• Read this operator's manual carefully before using the equipment.</li> <li>• An improper use of this machine can cause injuries to people or things.</li> <li>• Do not use this machine when under the influence of drugs or alcohol.</li> <li>• Do not modify the equipment under any circumstances.</li> <li>• Use products and solvents that are compatible with the various parts of the equipment, and read the manufacturer's warnings carefully.</li> <li>• See the Technical Details for the equipment given in the Manual.</li> <li>• Check the equipment for worn parts once a day. If any worn parts are found, replace them using <b>ONLY</b> original spare parts.</li> <li>• Keep children and animals away from work area.</li> <li>• Comply with all safety standards.</li> </ul>
	<ul style="list-style-type: none"> <li>• It indicates an accident risk or serious damage to equipment if this warning is not followed.</li> </ul>
   	<p><b>FIRE AND EXPLOSION HAZARD</b></p> <ul style="list-style-type: none"> <li>• Solvent and paint fumes in work area can ignite or explode.</li> <li>• <b>To help prevent fire and explosion:</b> <ul style="list-style-type: none"> <li>- Use equipment <b>ONLY</b> in well ventilated area.</li> <li>- Eliminate all ignition sources, such as pilot lights, cigarettes and plastic drop cloths (potential static arc).</li> <li>- Ground equipment and conductive objects.</li> <li>- Use only grounded hoses.</li> <li>- Do not use trichloroethane, methylene chloride, other halogenated hydrocarbon solvents or fluids containing such solvents in pressurized aluminium equipment. Such use can cause serious chemical reaction and equipment rupture, and result in death, serious injury, and property damage.</li> <li>- Do not form connections or switch light switches on or off if the air contains inflammable fumes.</li> </ul> </li> <li>• If electrical shocks or discharges are encountered the operation being carried out using the equipment <b>must be stopped immediately</b>.</li> <li>• Keep a fire extinguisher at hand in the immediate vicinity of the work area.</li> </ul>
	<ul style="list-style-type: none"> <li>• It indicates wound and finger squashing risk due to movable parts in the equipment.</li> <li>• Keep away from moving parts.</li> <li>• Do not use the equipment without the proper protection.</li> <li>• Before any inspection or maintenance of the equipment, carry out the decompression procedure explained in this manual, and prevent any risk of the equipment starting unexpectedly.</li> </ul>
 	<ul style="list-style-type: none"> <li>• Report any risk of chemical reaction or explosion if this warning has not been given.</li> <li>• (IF PROVIDED) There is a risk of injury or serious lesion related to contact with the jet from the spray gun. If this should occur, <b>IMMEDIATELY</b> contact a doctor, indicating the type of product injected.</li> <li>• (IF PROVIDED) Do not spray before the guard has been placed over the nozzle and the trigger on the spray gun.</li> <li>• (IF PROVIDED) Do not put your fingers in the spray gun nozzle.</li> <li>• Once work has been completed, before carrying out any maintenance, complete the decompression procedure.</li> </ul>
	<ul style="list-style-type: none"> <li>• It indicates important recommendations about disposal and recycling process of products in accordance with the environmental regulations.</li> </ul>
    	<ul style="list-style-type: none"> <li>• Mark any clamps attached to earth cables.</li> <li>• Use <b>ONLY</b> 3-wire extension cords and grounded electrical outlets.</li> <li>• Before starting work make sure that the electrical system is grounded and that it complies with safety standards.</li> <li>• High-pressure fluid from gun, hose leaks, or ruptured components will pierce skin.</li> <li>• <b>To help prevent injection, always:</b> <ul style="list-style-type: none"> <li>- (IF PROVIDED) Engage trigger lock when not spraying.</li> <li>- (IF PROVIDED) Do not put your hand over the spray tip. Do not stop or deflect leaks with your hand, body or other.</li> <li>- (IF PROVIDED) Do not point gun at anyone or at any part of the body.</li> <li>- (IF PROVIDED) Never spray without tip guard.</li> <li>- Do pressure relief if you stop spraying or being servicing sprayer and before any maintenance operations.</li> <li>- Do not use components rated less than sprayer Maximum Working Pressure.</li> <li>- Never allow children to use this unit</li> <li>- (IF PROVIDED) Brace yourself; gun may recoil when triggered.</li> </ul> </li> </ul> <p><b>If high pressure fluid pierces your skin, the injury might look like "just a cut", but it is a serious wound! Get immediate medical attention.</b></p>
   	<ul style="list-style-type: none"> <li>• It is obligatory to wear suitable clothing as gloves, goggles and face shield.</li> <li>• Wear clothing that complies with the safety standards in force in the country in which the equipment is used.</li> <li>• Do not wear bracelets, earrings, rings, chains, or anything else that may hinder the operator's work.</li> <li>• Do not wear clothing with wide sleeves, scarves, ties, or any other piece of clothing that could get tangled up in moving parts of the equipment during the work, inspection, or maintenance cycles.</li> </ul>

## B WORKING PRINCIPLE

The **LARIUS ECO K21** unit is defined “piston pump”.

An piston pump is used for high pressure painting without air (from this process derives the term “airless”).

The internal combustion engine, mounted upon the undercarriage, powers the alternative piston pump.

A cam shaft and a connecting rod allow to obtain the reciprocating motion necessary to the working of the “pumping group” piston. The piston movement produces a “vacuum”.

The product is sucked, pushed towards the pump outlet and then sent to the gun through the flexible hose.

A electronic device, allows to adjust and control the pressure of the material coming out of the pump.

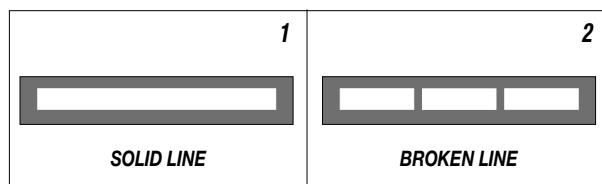
A safety valve avoiding overpressure, guarantees the total reliability of the equipment.

The control zone allows for the possibility of:

- Activating the dispensing spray gun;
- Enabling or disabling the frontal steering wheel;
- Adjust the pressure of work;

This type of equipment is capable of painting one line at a time in a single color.

The line can be either solid or dotted, based on the working requirements.



**ECO K21** is ideal for medium marking and maintenance jobs.



**Use water or non-refractive solvent filtered paint specifically designed for airless application.**

**ECO K21** allows for the marking and maintaining of all types lines on highways, freeways, pedestrian crossings, parking lots and squares, as well as every horizontal marking required by the highway code.

Airless marking has numerous proven benefits with respect to line-markers with pressurised tanks, which have been rendered obsolete by airless-technology line markers.

Airless line-marking guarantees:

- Decreased Environmental Impact;
- Decreased drying time.

The paint dries quickly and the line is defined in a uniform manner with a single coat. The airless function requires the use of filtered paint which is specifically designed for airless application. This means that the paint is homogeneous, of a smooth and uniform consistency and will not form crusts, nor will it become gelatinous or thick. With this airless line-marker, the paint adheres firmly to all types of pavement, with optimal visibility, and is resistance to wear caused both by traffic as well as atmospheric agents.



Fig. 1

In these models, the paint canister can be loaded directly upon the undercarriage or else poured into the non-stick, 50 L tank. In every case, cleaning, maintenance and colour change operations are facilitated.



Fig. 2

The line-marker is equipped with pivoting frontal wheel which even increases the agility of the larger models. High yield, high efficiency, high versatility.

This line-marker utilises non-premixed paints. This allows it to achieve about 30 % more yield with respect to standard line-markers. Every model is also an airless spray gun which can be used in the construction/decoration sector together with washable products, enamels, breathable paints and flooring resins. A vast assortment of accessories is available to satisfy every customer demand.

## C TECHNICAL DATA

ECO K21	
Max pressure	220 bar
Max flow rate	2,2 l/m
240 A/hPower supply	No. 4 batteries - 6V
Electric pump engine power	0,75 kW
Electric motor power for traction	0,50 kW
Airless paint capacity	50 lt gravity tank
Dimensions	1.920 x 1450 x 1.580 mm
Weight	280 Kg

### SECTORS OF USE

- External or underground parking lots (schools, hotels, airports, supermarkets, train stations, subway stations, ports);
- External public areas;
- Industrial and exhibition building zones;
- Freeway service areas and service stations;
- Pedestrian median lines, intersections, bicycle tracks, reserved lanes;
- Internal and external logistic area markings;
- Playing fields.



### SFC SPRAY TIPS/NOZZLES TABLE - TSC

Ø nozzle (inch)	Spray angle (°)	Line Width		Flow rate (gpm)	Flow rate (lpm)
		inch	mm		
.013	13 - 20	2 - 4	51 - 102	.18	.69
	15 - 20	2 - 4	51 - 102		
.015	15 - 30	4 - 6	102 - 152	.24	.91
	17 - 20	2 - 4	51 - 102		
.017	17 - 30	4 - 6	102 - 152	.31	1.17
	17 - 40	4 - 8	102 - 204		
	19 - 20	2 - 4	51 - 102		
.019	19 - 30	4 - 6	102 - 152	.38	1.47
	19 - 40	4 - 8	102 - 204		
	21 - 30	4 - 6	102 - 152		
.021	21 - 40	4 - 8	102 - 204	.47	1.79
	21 - 60	8 - 12	204 - 305		
	23 - 30	4 - 6	102 - 152		
.023	23 - 40	4 - 8	102 - 204	.57	2.15
	23 - 60	8 - 12	204 - 305		
	25 - 30	4 - 6	102 - 152		
.025	25 - 40	4 - 8	102 - 204	.67	2.54
	25 - 60	8 - 12	204 - 305		
	27 - 30	4 - 6	102 - 152		
.027	27 - 40	4 - 8	102 - 204	.77	2.96
	27 - 60	8 - 12	204 - 305		

Ø nozzle (inch)	Spray angle (°)	Line Width		Flow rate (gpm)	Flow rate (lpm)
		inch	mm		
.029	29 - 30	4 - 6	102 - 152	.90	3.42
	29 - 40	4 - 8	102 - 204		
	29 - 60	8 - 12	204 - 305		
.031	31 - 30	4 - 6	102 - 152	1.03	3.90
	31 - 40	4 - 8	102 - 204		
	31 - 60	8 - 12	204 - 305		
.033	33 - 30	4 - 6	102 - 152	1.17	4.42
	35 - 30	4 - 6	102 - 152		
.035	35 - 40	4 - 8	102 - 204	1.31	4.98
	35 - 60	8 - 12	204 - 305		
	39 - 30	4 - 6	102 - 152		
.039	39 - 40	4 - 8	102 - 204	1.63	6.18
	39 - 60	8 - 12	204 - 305		
	43 - 30	4 - 6	102 - 152		
.043	43 - 40	4 - 8	102 - 204	1.98	7.51
	43 - 60	8 - 12	204 - 305		

Code	Battery	Self propelled	50 lt gravity tank	Airless hose	AT250 Manual Airless gun	Airless nozzle holder	Super Fast Clean airless nozzles
4200	•	•	•	N°1 Cod. 35015 Ø 1/4"-M16x1,5-10m	N°1 Cod. 11210 M16x1,5 inlet swivel	N°1 Cod. 18270	N°1 SFC 11-40 N°1 SFC 13-40 N°1 SFC 17-40

CONFIGURATIONS	
Part No.	4861
Battery power	0,75 kW
Max. Flow rate	2,2 l/min
Max. Pressure	220 bar
Self-propelled	•
Head control system	•
Automatic marking lines kit	–
Flashing telescopic rod kit	–
Working light kit	–
Operator footboard kit	–
Piston type accumulator	–
50 L Gravity tank	•

CONFIGURATIONS	
Part No.	4861
Airless hose Ø 1/4" - M16 x 1,5 - 10M	•
Recirculation Hose	•
Filter with pressure gauge	•
1 AT250 Airless manual spray gun	•
Airless nozzle holder	•
Super fast clean airless spraying nozzles	•
1 colour	•
1 single line: continuous - dashed	•
Battery charger	•
Tools kit	•

ACCESSORIES	
Part No.	Description
18026	Airless hose Ø 1/4" - M16 x 1,5 - 15 m
11200	AT250 manual airless spray gun - M16x1,5 inlet swivel + Nozzle holder
11210	AT250 manual airless spray gun - M16x1,5 inlet swivel
11701	LA96 automatic airless spray gun - M16x1,5 inlet swivel + Nozzle holder
18270	Airless nozzle holder
SFC	Super Fast Clean airless nozzle. Size from 11-20 to 51-80
TSC	Super Fast Clean airless nozzle. Size from 7-20 to 31-60
18240	50 l Gravity tank
18245	50 l Gravity tank + Cover
18241	50 l Gravity tank + Cover + Basket
4500	11 l Gravity tank + Glass beads diffuser hose
26000	Operator footboard
4720	Seat kit
4605	Battery charger

KITS	
Part No.	Description
4307/1	Mounting kit for second airless gun (airless gun not included)
18359	11 l Gravity tank + 1 Diffuser hose + 1 Glass beads manual spray gun kit
18354	11 l Gravity tank + 1 Diffuser hose + 2 Glass beads manual spray guns kit
4038	Laser pointer kit
4506	Working light kit
4507	Flashing telescopic rod kit

## D DESCRIPTION OF THE EQUIPMENT



Fig. 1

Pos.	Description
1	Control box
2	Advancement/retreat lever
3	Gun operating lever
4	Manometer
5	Product supply tube
6	Product recirculation tube

Pos.	Description
7	Flow compensator
8	Gun
9	Recirculation group
10	Pressure sensor
11	Filter
12	Safety-recirculation valve

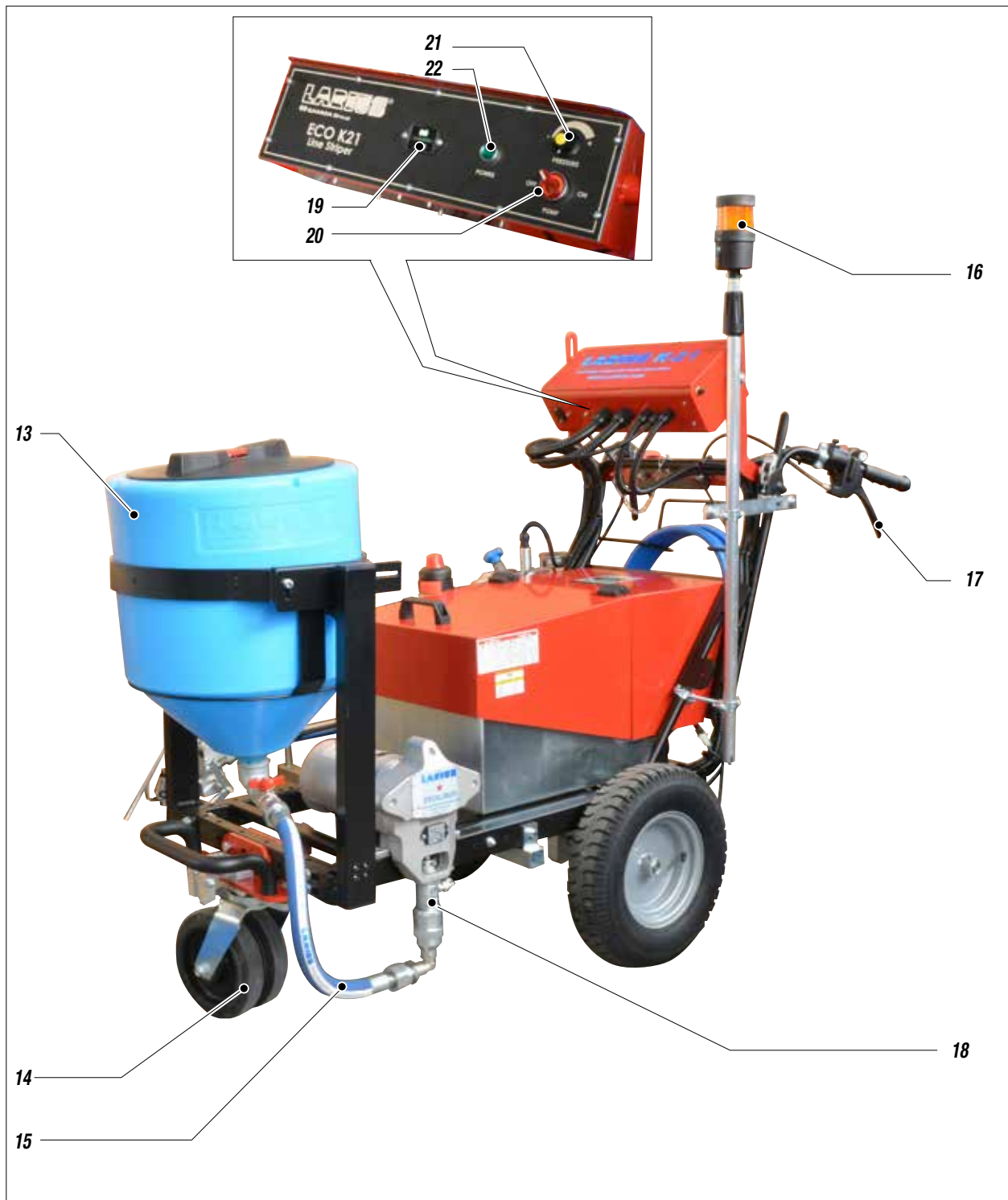


Fig. 2

Pos.	Description
13	Tank
14	Pivoting wheel
15	Product supply tube

Pos.	Description
18	Pumping group
19	Battery level indicator
20	Pump ignition selection
21	Pressure increase/reduction handle
22	Indicator light

## E CONTROLS DESCRIPTION

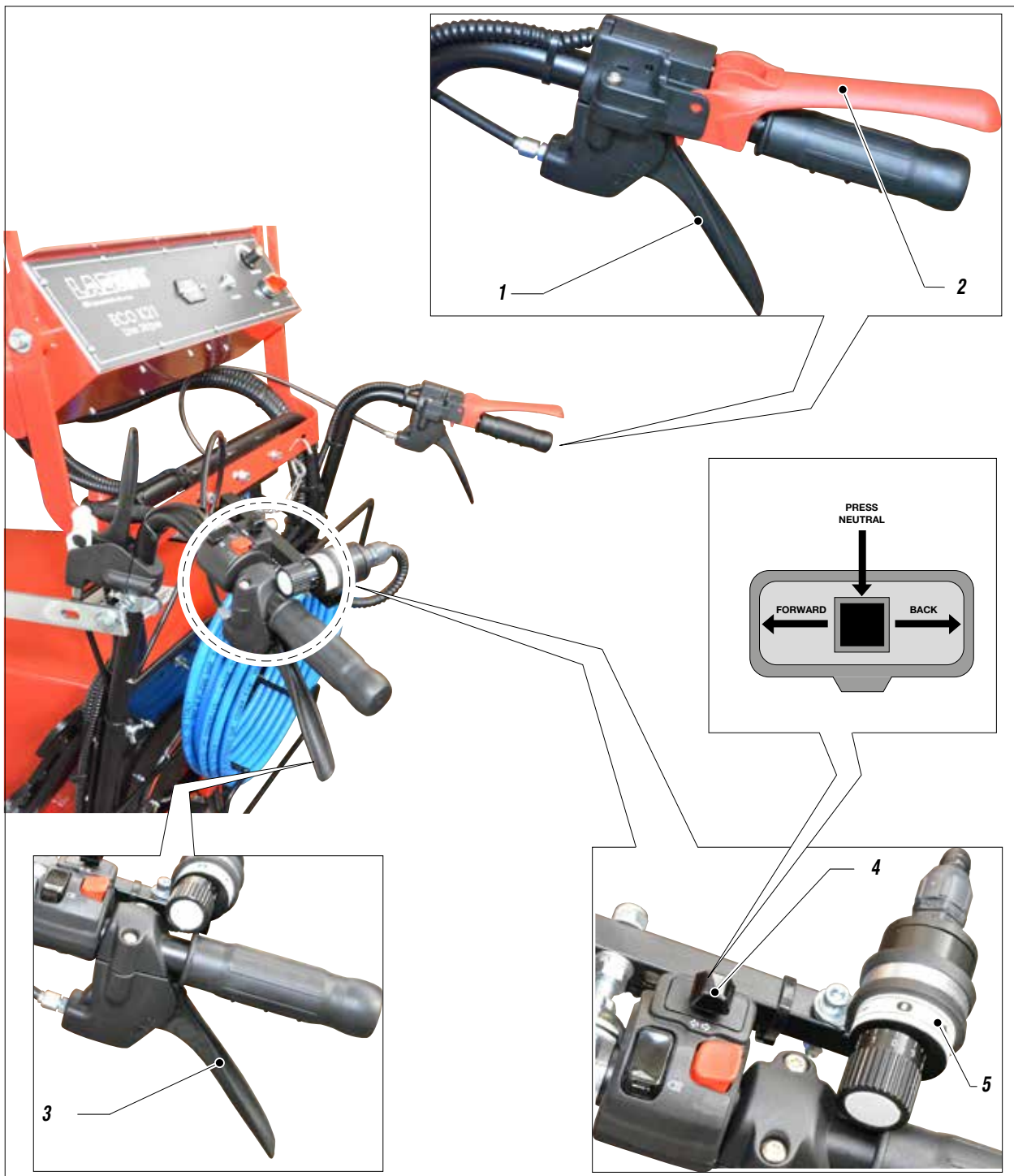


Fig. 1

Pos.	Description
1	<b>Gun operating lever:</b> pulling the lever <b>1</b> enables gun operation.
2	<b>Advancement lever:</b> pulling the drive lever <b>2</b> enables the machine to run.
3	<b>Directional lever:</b> Pulling the lever <b>3</b> to release the linear drive lock and allow the machine to perform curved line tracts through the pivoting wheel.

Pos.	Description
4	<b>Direction selector:</b> the selector <b>4</b> allows to select the machine's advancement direction. Pressing the selector <b>4</b> in central position the gear is disengaged and remains in neutral.
5	<b>Speed regulation handle:</b> the speed regulation handle <b>5</b> allows to gradually regulate the machine's advancement speed.

## F PANEL DESCRIPTION

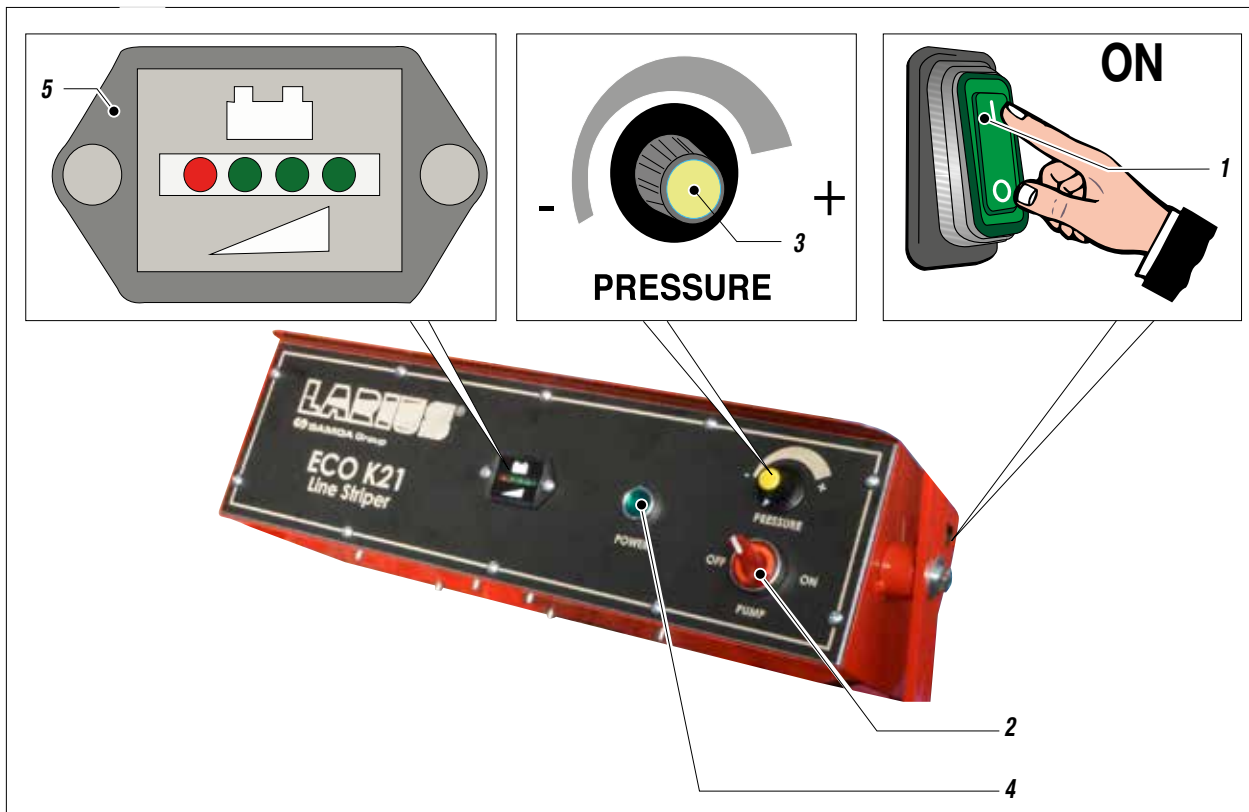


Fig. 1

Pos.	Description
1	<b>General switch:</b> placing button 1, located on the side of the control panel, in position "I" turns on the liner.
2	<b>Pump power on:</b> moving selector 2 to <b>ON</b> the pump starts.
3	<b>Pressure regulation handle:</b> regulation handle 3 allows to regulate the pump pressure.

Pos.	Description
4	<b>Tension indicator light:</b> green indicator light 4, if on, indicates the presence of electrical tension in the machine.
5	<b>Battery level:</b> leds 5 indicate the battery charge status.

## G TRANSPORT AND UNPACKING

- The packed parts should be handled as indicated in the symbols and markings on the outside of the packing.
- Before installing the equipment, ensure that the area to be used is large enough for such purposes, is properly lit and has a clean, smooth floor surface.
- The user is responsible for the operations of unloading and handling and should use the maximum care so as not to damage the individual parts or injure anyone.

To perform the unloading operation, use only qualified and trained personnel (truck and crane operators, etc.) and also suitable hoisting equipment for the weight of the installation or its parts.

Follow carefully all the safety rules.

The personnel must be equipped with the necessary safety clothing.

- The manufacturer will not be responsible for the unloading

operations and transport to the workplace of the machine.

- Check the packing is undamaged on receipt of the equipment. Unpack the machine and verify if there has been any damage due to transportation.

In case of damage, call immediately the Manufacturer and the Shipping Agent. All the notices about possible damage or anomalies must arrive timely within 8 days at least from the date of receipt of the plant through Registered Letter to the Shipping Agent and to the Manufacturer.



**The disposal of packaging materials is a customer's competence and must be performed in accordance with the regulations in force in the country where the plant is installed and used. It is nevertheless sound practice to recycle packaging materials in an environment-friendly manner as much as possible.**

## H CONDITIONS OF GUARANTEE

The conditions of guarantee do not apply in the following situations:

- improper washing and cleaning of components causing malfunction, wear or damage to the equipment or any of its parts;
- improper use of the equipment;
- use that does not conform with applicable national legislation;
- incorrect or faulty installation;
- modifications, interventions and maintenance that have not been authorised by the manufacturer;
- use of non-original spare parts or parts that do not correspond to the specific model;
- total or partial non-compliance with the instructions provided.



## I SAFETY RULES

Read carefully and entirely the following instructions before using the product. Please save these instructions in a safe place.



The unauthorised tampering/replacement of one or more parts composing the machine, the use of accessories, tools, expendable materials other than those recommended by the manufacturer can be a danger of accident.

The manufacturer will be relieved from tort and criminal liability.

- THE EMPLOYER SHALL TRAIN ITS EMPLOYEES ABOUT ALL THOSE RISKS STEMMING FROM ACCIDENTS, ABOUT THE USE OF SAFETY DEVICES FOR THEIR OWN SAFETY AND ABOUT THE GENERAL RULES FOR ACCIDENT PREVENTION IN COMPLIANCE WITH INTERNATIONAL REGULATIONS AND WITH THE LAWS OF THE COUNTRY WHERE THE PLANT IS USED.
- THE BEHAVIOUR OF THE EMPLOYEES SHALL STRICTLY COMPLY WITH THE ACCIDENT PREVENTION AND ALSO ENVIRONMENTAL REGULATIONS IN FORCE IN THE COUNTRY WHERE THE PLANT IS INSTALLED AND USED.
- KEEP YOUR WORK PLACE CLEAN AND TIDY. DISORDER WHERE YOU ARE WORKING CREATES A POTENTIAL RISK OF ACCIDENTS.
- ALWAYS KEEP PROPER BALANCE AVOIDING UNUSUAL STANCE.
- BEFORE USING THE TOOL, ENSURE THERE ARE NOT DAMAGED PARTS AND THE MACHINE CAN WORK PROPERLY.
- ALWAYS FOLLOW THE INSTRUCTIONS ABOUT SAFETY AND THE REGULATIONS IN FORCE.
- KEEP THOSE WHO ARE NOT RESPONSIBLE FOR THE EQUIPMENT OUT OF THE WORK AREA.
- **NEVER** EXCEED THE MAXIMUM WORKING PRESSURE INDICATED.

- (IF PROVIDED) **NEVER** POINT THE SPRAY GUN AT YOURSELVES OR AT OTHER PEOPLE. THE CONTACT WITH THE CASTING CAN CAUSE SERIOUS INJURIES.
- IN CASE OF INJURIES CAUSED BY THE GUN CASTING, SEEK IMMEDIATE MEDICAL ADVICE SPECIFYING THE TYPE OF THE PRODUCT INJECTED. **NEVER** UNDERVALUE A WOUND CAUSED BY THE INJECTION OF A FLUID.
- ALWAYS DISCONNECT THE SUPPLY AND RELEASE THE PRESSURE IN THE CIRCUIT BEFORE PERFORMING ANY CHECK OR PART REPLACEMENT OF THE EQUIPMENT.
- NEVER MODIFY ANY PART IN THE EQUIPMENT. CHECK REGULARLY THE COMPONENTS OF THE SYSTEM.  
REPLACE THE PARTS DAMAGED OR WORN.
- (IF PROVIDED) TIGHTEN AND CHECK ALL THE FITTINGS
- FOR CONNECTION BETWEEN PUMP, FLEXIBLE HOSE AND SPRAY GUN BEFORE USING THE EQUIPMENT.
- ALWAYS USE THE FLEXIBLE HOSE SUPPLIED WITH STANDARD KIT.
- THE USE OF ANY ACCESSORIES OR TOOLING OTHER THAN THOSE RECOMMENDED IN THIS MANUAL, MAY CAUSE DAMAGE OR INJURE THE OPERATOR.
- THE FLUID CONTAINED IN THE FLEXIBLE HOSE CAN BE VERY DANGEROUS. HANDLE THE FLEXIBLE HOSE CAREFULLY. DO NOT PULL THE FLEXIBLE HOSE TO MOVE THE EQUIPMENT. NEVER USE A DAMAGED OR A REPAIRED FLEXIBLE HOSE



The high speed of travel of the product in the hose can create static electricity through discharges and sparks. It is suggested to earth the equipment. The pump is earthed through the earth cable of the supply. The gun is earthed through the high pressure flexible hose.



All the conductors near the work area must be earthed.



Always check that the product is compatible with the materials composing the equipment (*pump, spray gun, flexible hose and accessories*) with which it can come into contact. Never use paints or solvents containing Halogen Hydrocarbons (as the *Methylene Chloride*). If these products come into contact with aluminium parts can provoke dangerous chemical reactions with risk of corrosion and explosion.



If the product to be used is toxic, avoid inhalation and contact by using protection gloves, goggles and proper face shields. Take proper safety measures for the protection of hearing in case of work near the plant.

## J TUBES CONNECTION

### Flexible re-circulation tube connection from the tank to the re-circulation group

- Connect the flexible re-circulation tube (1) to the connector (2) ensuring to tighten the fittings (the use of two wrenches is suggested) and insert the tube in the tank (3) as indicated in figure.

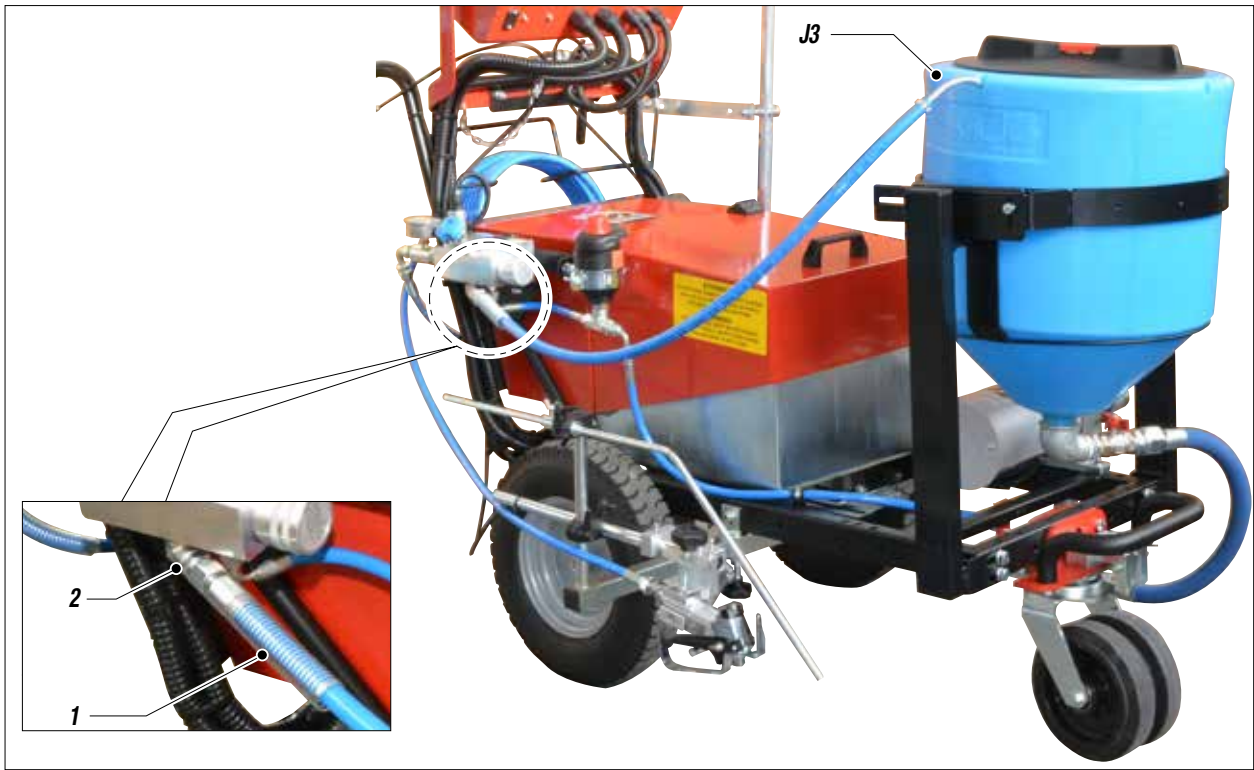


Fig. 1

### Pump unit tube connection from tank to the pump

- Connect the pump unit tube (4) from the pumping group connector (5) to the tank connector (6) ensuring to tighten the fittings (the use of two wrenches is suggested).

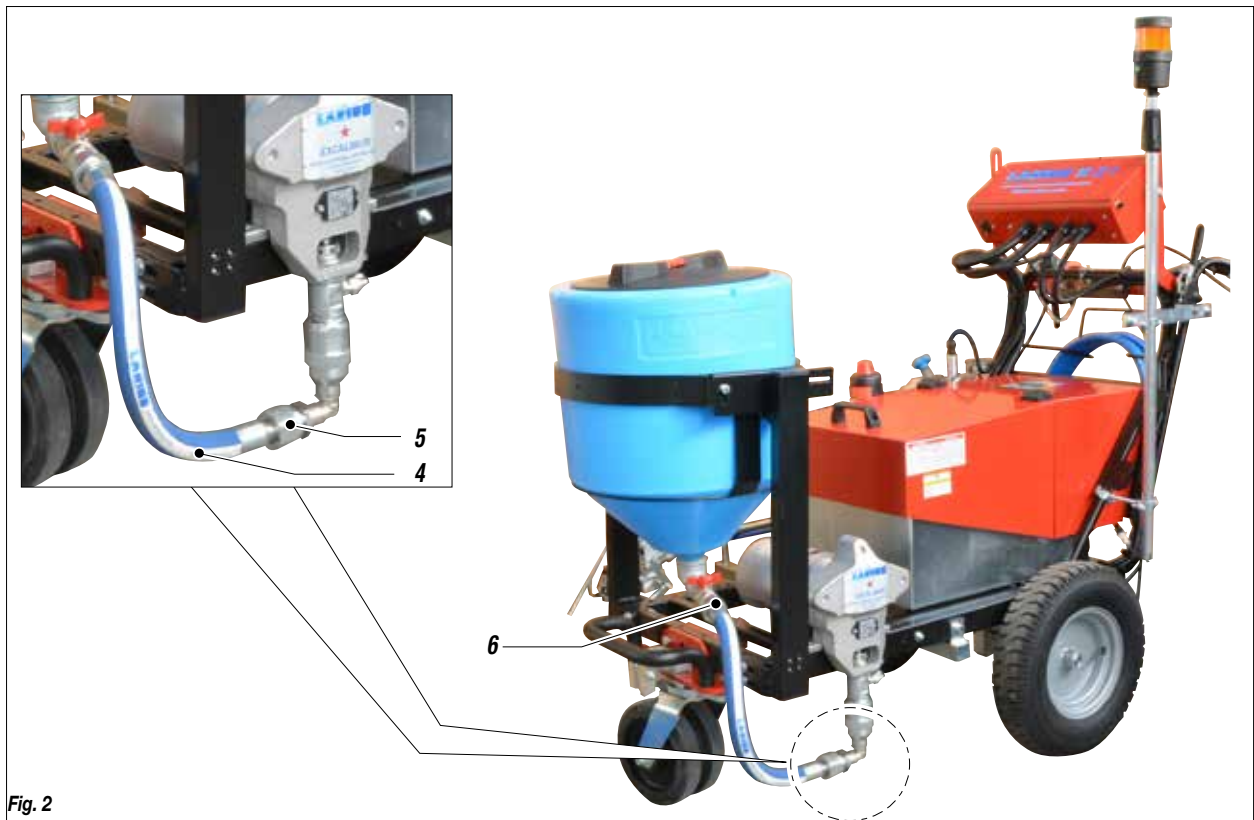


Fig. 2

### Flexible tube connection from the pump to the flow compensator

- Connect the flexible tube (7) from *Excalibur* pump connector (J8) to the flow compensator connector (9) ensuring to tighten the fittings (the use of two wrenches is suggested).



Fig. 3

**Flexible tube connection from flow compensator to re-circulation group**

- Connect flexible tube (10) from flow compensator connector (9) to re-circulation group connector (11) ensuring to tighten the fittings (the use of two wrenches is suggested).

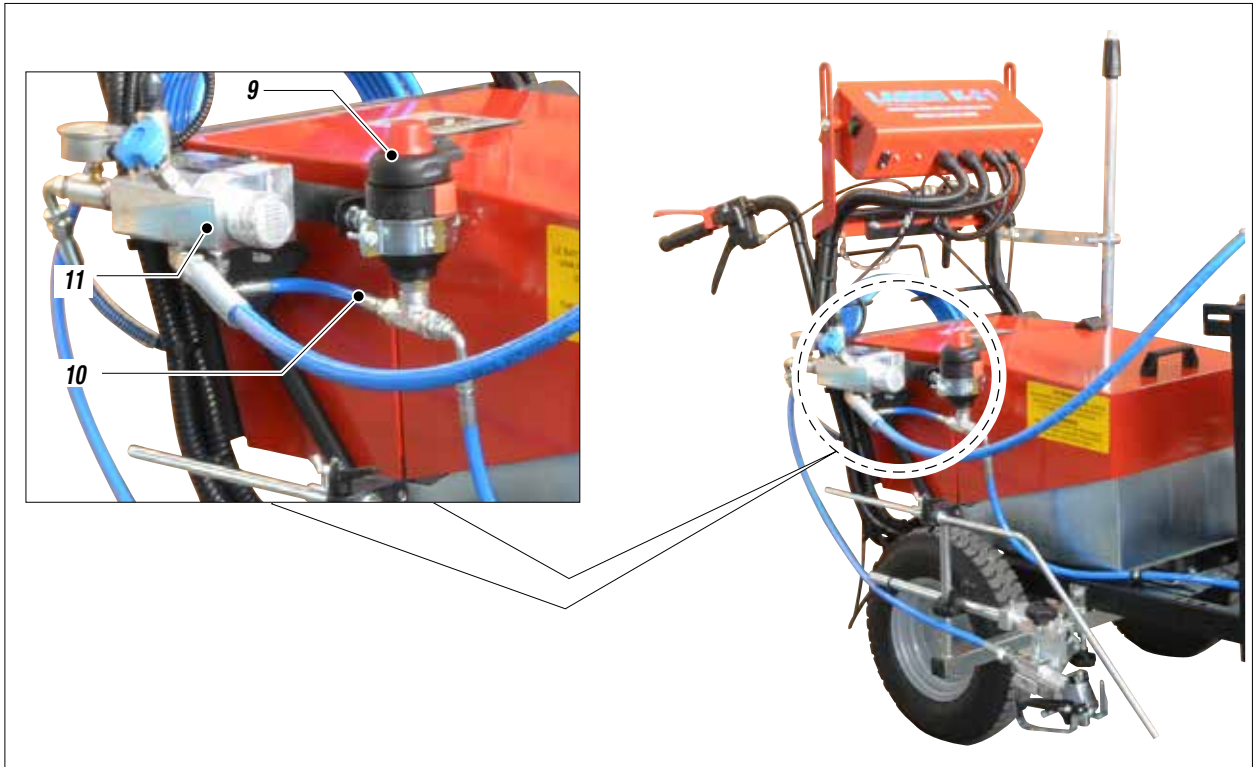


Fig. 4

**Flexible tube connection from re-circulation group to the gun**

- Connect the flexible tube (12) from the re-circulation group connector (13) to the gun group connector (14) ensuring to tighten the fittings (the use of two wrenches is suggested).

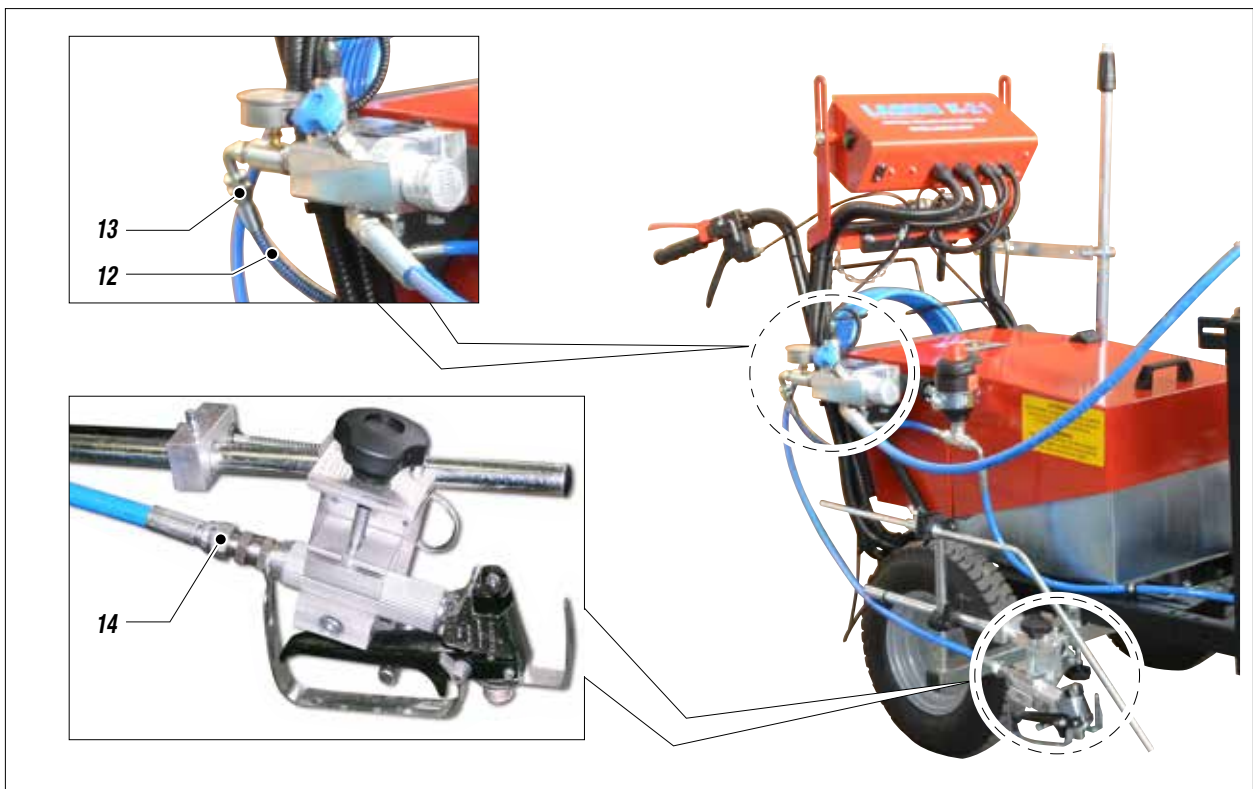


Fig. 5

## K WASHING OF THE NEW EQUIPMENT

- The equipment has already been adjusted at our factory with light mineral oil left inside the pumping group as protection. Therefore, wash with diluent before sucking the product.
- Fill the product tank with wash fluid
- Clean the inside of the tank with a brush.
- Ensure the gun (1) is without the nozzle.



Fig. 1

- Start the motor pressing lateral switch (2) to "1" (ON) and rotate the starting pump selector (3), placed on the front of the panel, to ON.

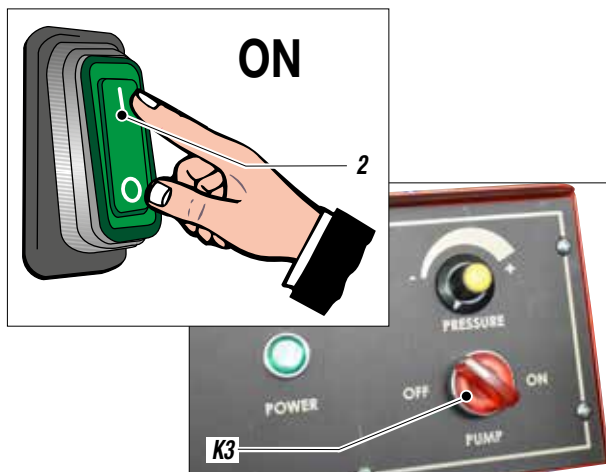


Fig. 2

- Open the recirculating-safety valve (4), as shown in Fig. 4



Fig. 3

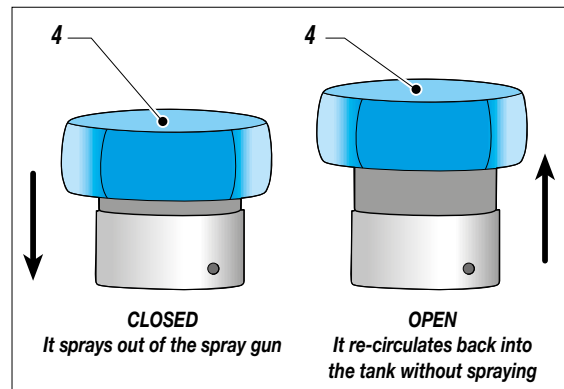


Fig. 4

- Turn the pressure setting knob (5) clockwise until the machine works to the minimum.

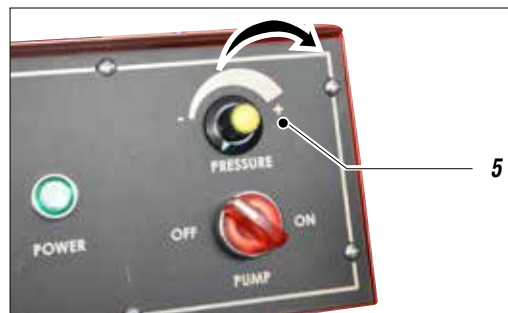


Fig. 5

- Visually check that the wash fluid starts to re-circulate within the tank (6).

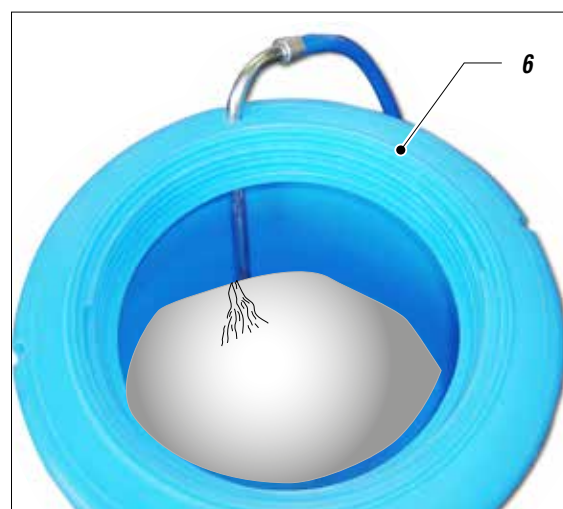


Fig. 6

- Turn the pressure setting knob (5) counter-clockwise to stop the pump.

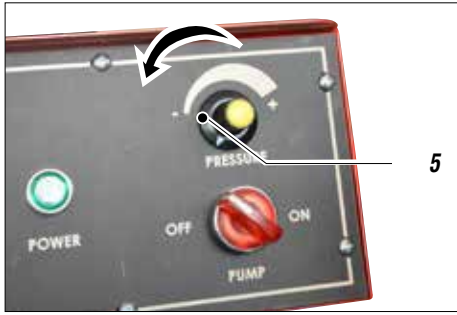


Fig. 7

- Closed the re-circulating safety valve (4).

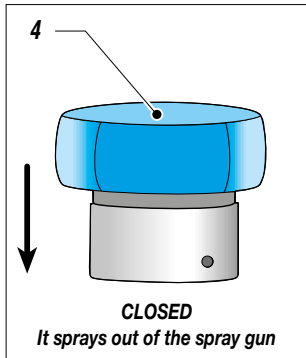


Fig.

- Turn pressure regulating knob (K5) clockwise a little so that the machine idles.

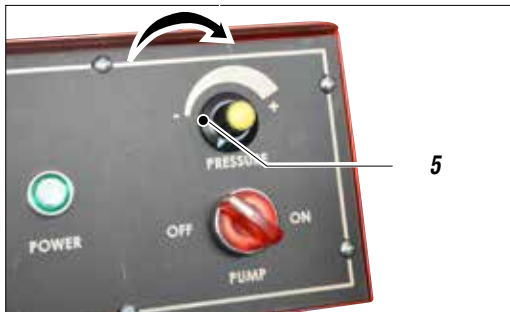


Fig. 9

- Remove the gun (7) from its support and point it into a container (8). Hold the trigger down (to perform the cleaning) until clean solvent comes out, or else until all of the wash fluid has been expelled from the tank.

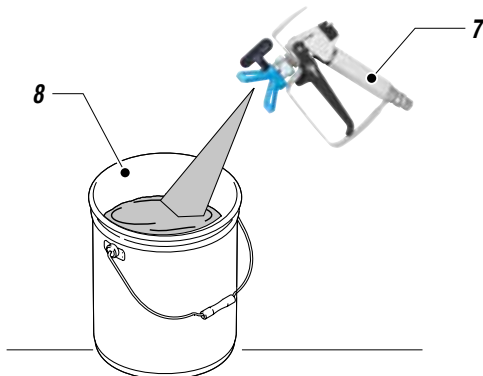


Fig. 9



Repeat the same operations with clean solvent if necessary.

- After having completed the wash operations, bring the handle to its MIN position (5) and point the gun (7) into a collection container (8) and press the trigger to release the residual pressure. Release the trigger when finished.



Fig. 10

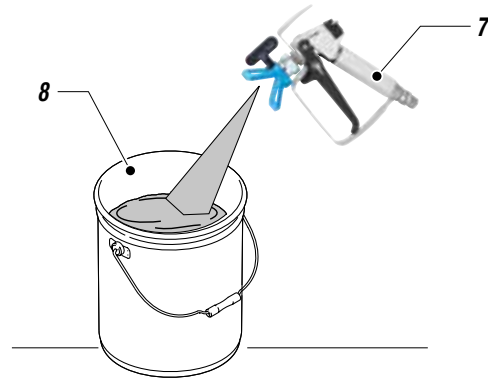


Fig. 11



Absolutely avoid to spray solvents indoors. In addition, it is recommended to keep away from the pump in order to avoid the contact between the solvent fumes and the motor.

- Shut off the equipment by turning the switch to its **OFF** position "(O)".
- At this point the machine is ready. If water-based paints are to be used, after the wash with solvent wash the tank again with soap and water, then rinse with clean water (repeating the previously described procedures).
- Insert the manual gun trigger lock and assemble the nozzle.

## L PRODUCT PREPARATION



**MAKE SURE THE PRODUCT IS SUITABLE TO BE USED WITH A SPRAY GUN.**

- Mix and filter the product before using it. For filtration use **CLOSE-MESH** (rif. 214) and **LARGE-MESH** (rif. 215) **LARIUS METEX** braids.



**Make sure the product to be used is compatible with the materials employed for manufacturing the equipment (stainless steel and aluminium). Because of that, please contact the supplier of the product.**

Never use products containing halogen hydrocarbons (as *methylene chloride*). If these products come into contact with aluminium parts of the equipment, can provoke dangerous chemical reactions with risk of explosion.

- Fill the tank (L) with the paint.



Fig. 1

## M GUN ASSEMBLING AND REGULATIONS

### GUN ASSEMBLING

- Assemble the gun (1) on the gun holder arm (2) ensuring to tighten the handle (3).

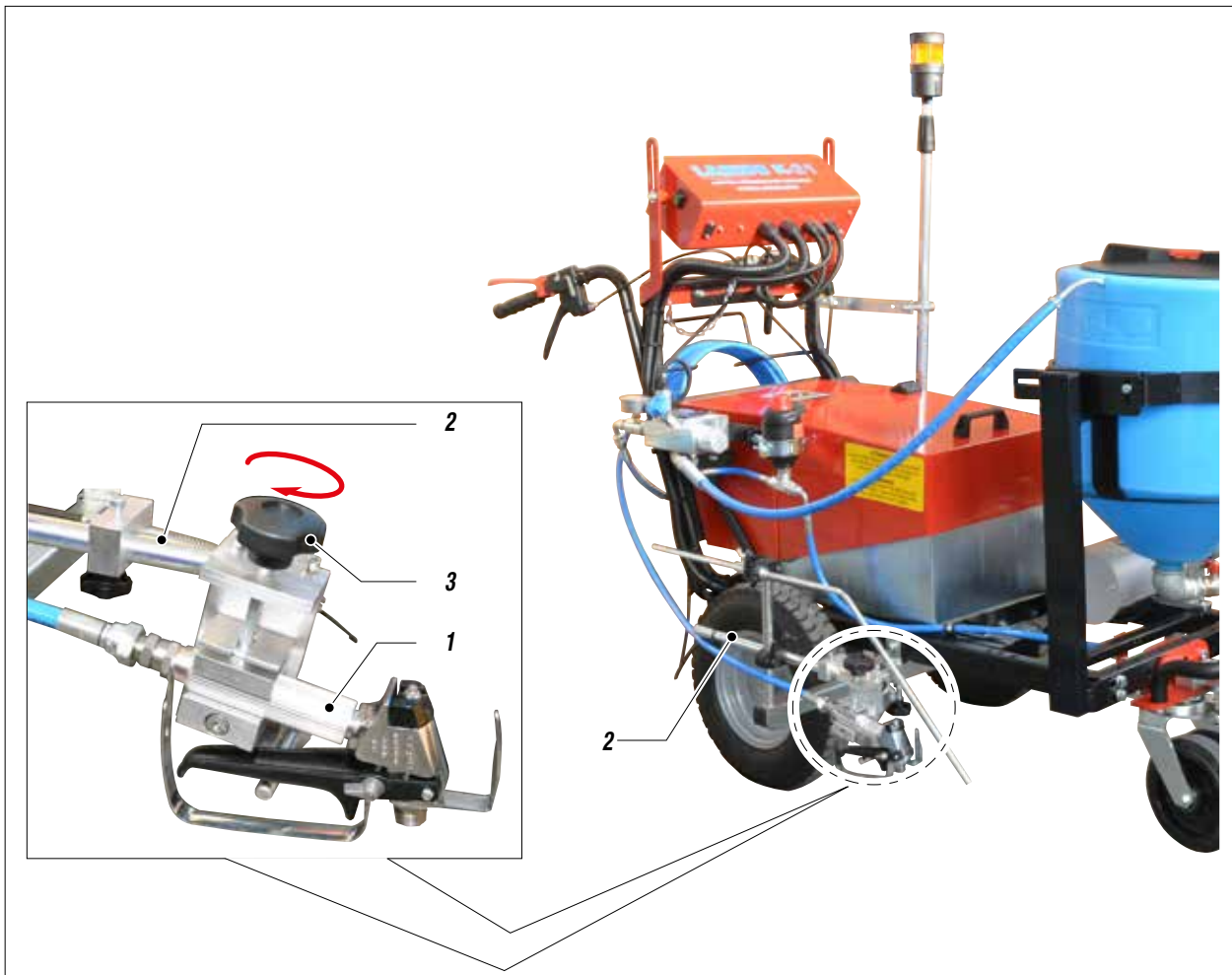


Fig. 1

### COMPLETE ARM GROUP REGULATION

- The position of the complete support group (4) can be adjusted outwards or inwards by acting on the knob (5), allowing at the same time the adjustment of the position of both the gun unit and the reference rod externally or internally. To allow the arm to move it is necessary to loosen the appropriate knob (5). Once the adjustment is complete, the knob will be locked again.

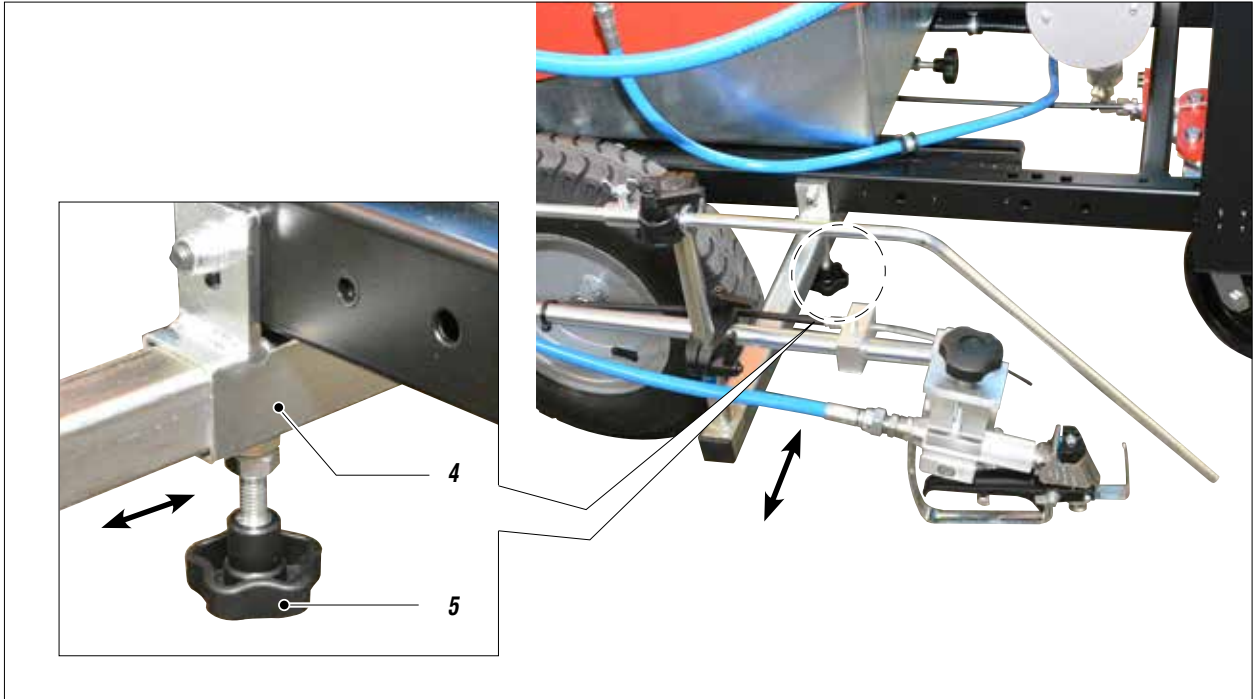


Fig. 2

### REFERENCE ROD REGULATION

- The reference rod can be moved up or down by acting on the handle (6) or forward or backward through the handle (7). Once placed in the desired position, the handles must be locked again.

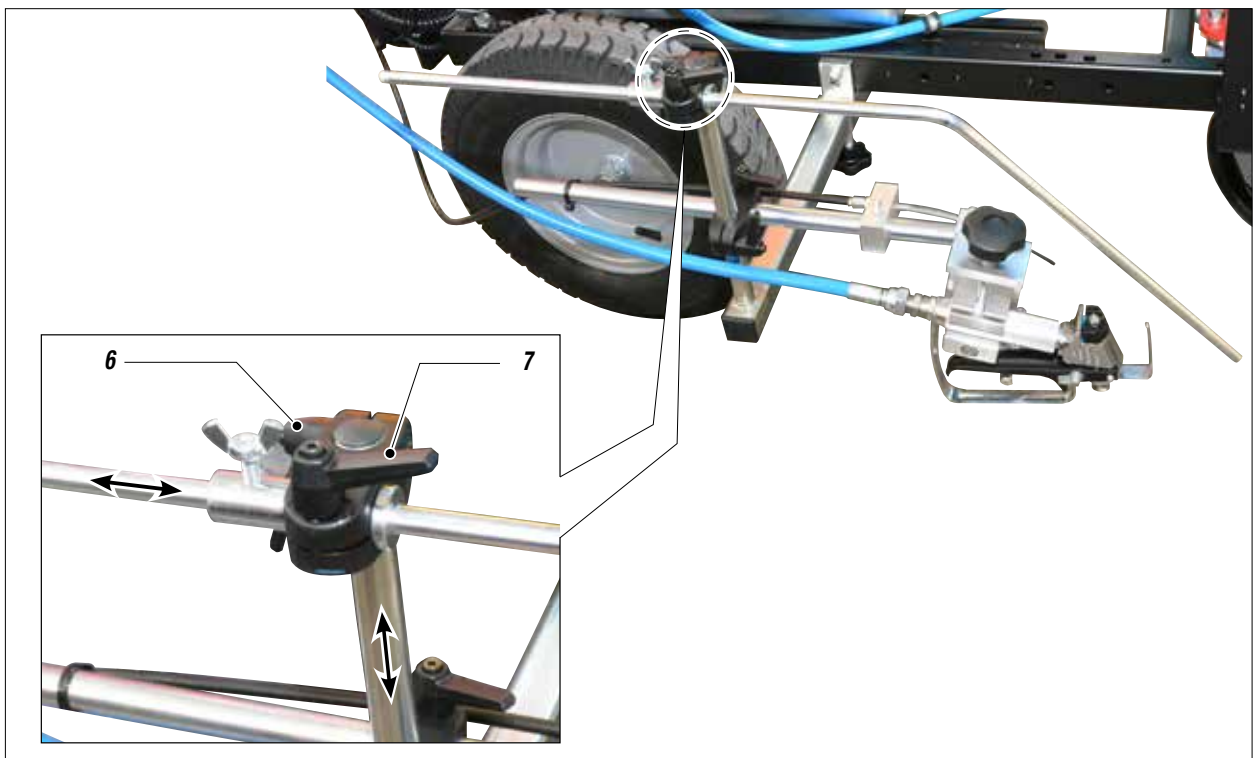


Fig. 3

## GUN HOLDER ARM REGULATION

- The gun holder arm can be moved up or down using the handle (8) or forward or backward using the handle (9). Once placed in the desired position, the handles must be locked again.

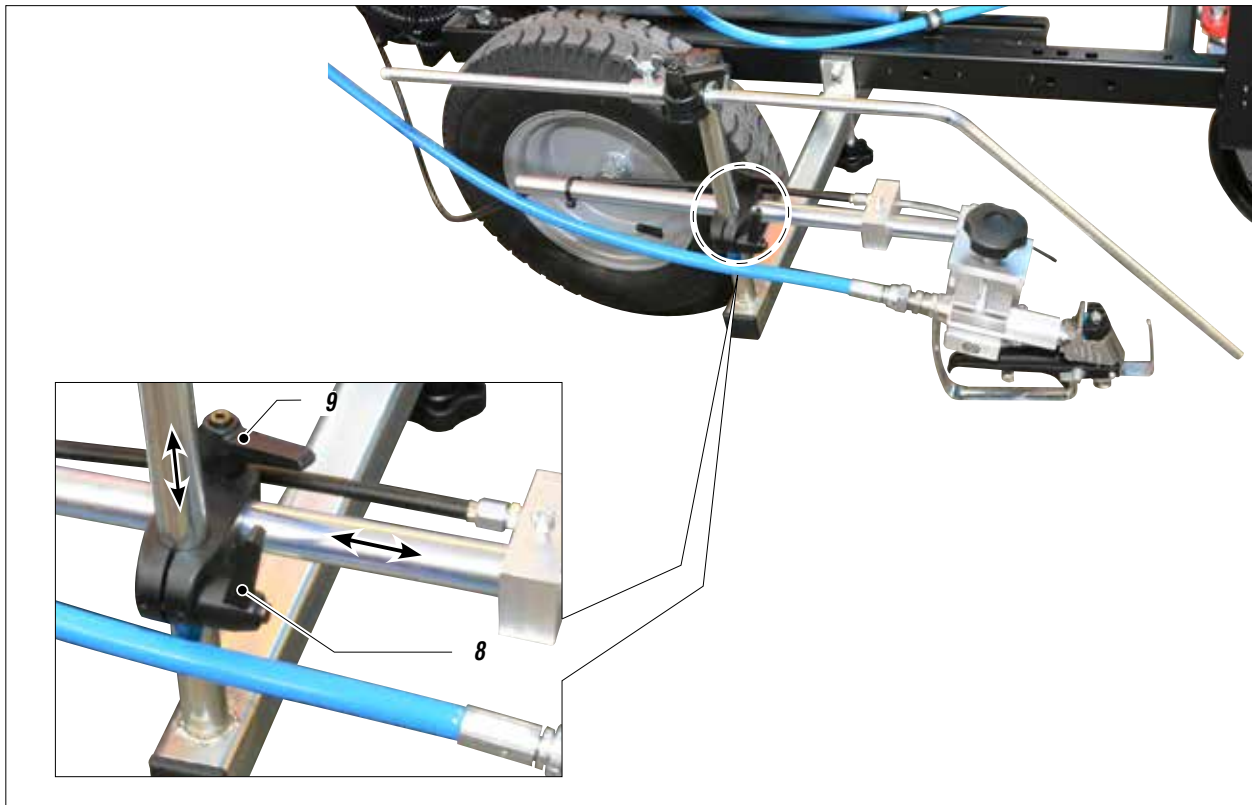


Fig. 4

## N WORKING

### SETUP PROCEDURE

- Use the tooling after performing all the operations described in the previous pages.
- Make sure that the re-circulation/safety valve (1) is closed (spray enabled).

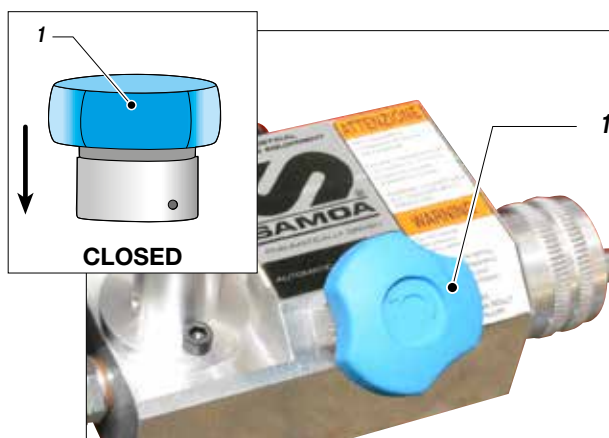


Fig. 1

- Press the switch (N2) of the equipment "ON" (I).
- Turn the pump activate selector (3), placed in front of the panel, to ON.

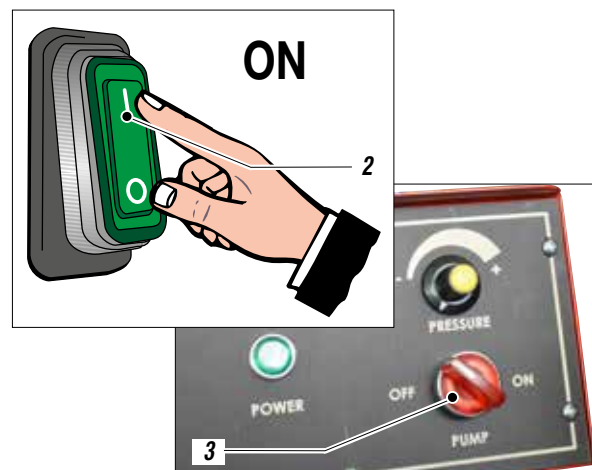


Fig. 2

### SPRAY ADJUSTMENT

- Slowly turn clockwise the pressure control knob (4) to reach the pressure value in order to ensure a good atomization of the product.
- An irregular and marked spray on the sides indicates a low working pressure. On the contrary, a too high pressure causes a high fog ("overspray") and waste of product.
- Pull the right lever (N5) to activate the gun and start working by constantly advancing the machine by acting on the lever (N6).

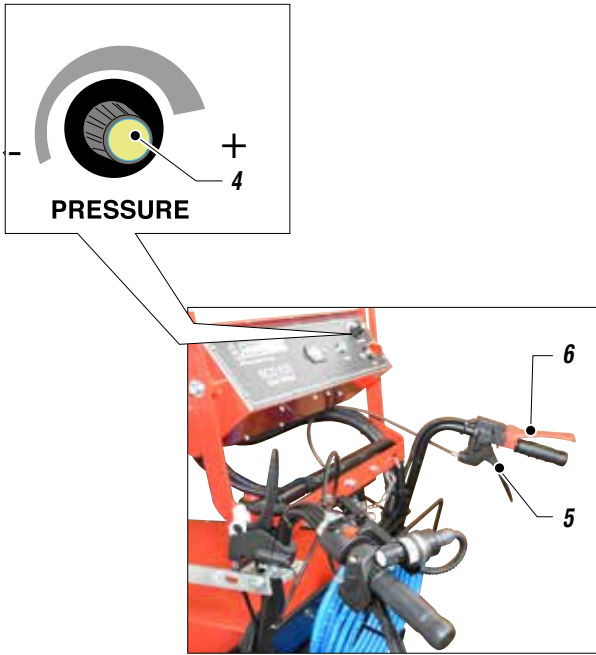


Fig. 3



**NEVER** point the spray gun at yourselves or at other people. The contact with the casting can cause serious injuries. In case of injuries caused by the gun casting, seek immediate medical advice specifying the type of the product injected.



**Recirculating-safety valve:** when working at the maximum pressure available, releasing the gun trigger sudden increases of pressure can occur. In this case, the recirculating-safety valve opens automatically eliminating part of the product from the recirculating tube. Then it closes so as to go back to the first working conditions.

## 0 CLEANING AT THE END WORK

- Reduce pressure to the minimum (turn counterclockwise the pressure control knob (1)).



Fig. 1

- Release the residual pressure by holding down the trigger of the gun (2) and pointing it into a container (3).

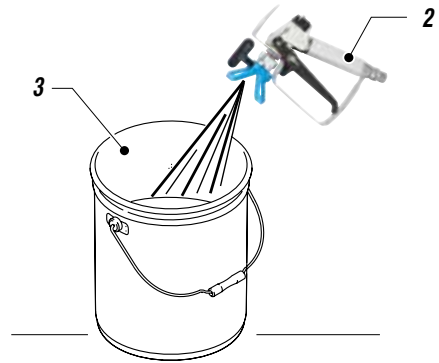


Fig. 2

- Eliminate the paint remaining within the tank (4) by placing the re-circulation tube (5) into a container (6).
- Open the recirculating-safety valve (7).

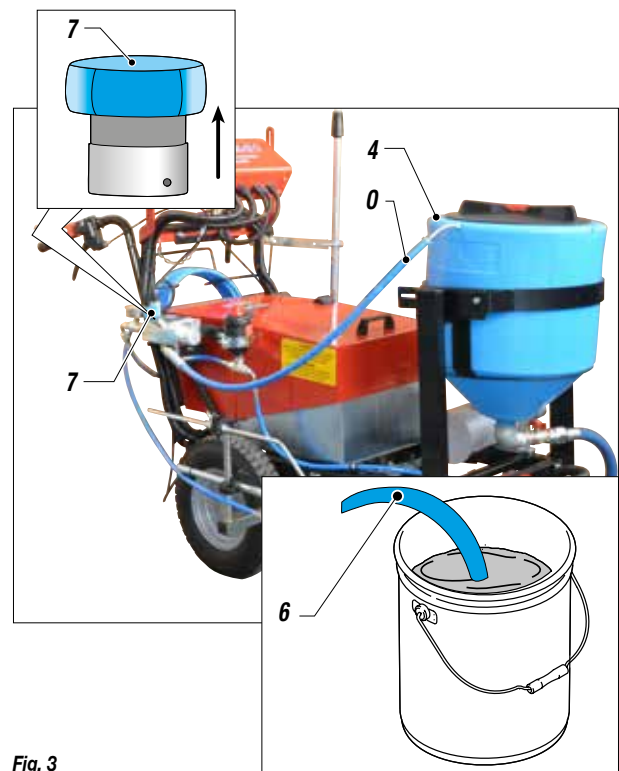


Fig. 3

- Turn the pressure adjustment (1) handle slightly clockwise to make the machine function at minimum pressure (pump activated), until the tank has been completely emptied then shut off the pump by bringing the handle (1) to its minimum position.
- Fill the tank (4) with wash fluid.

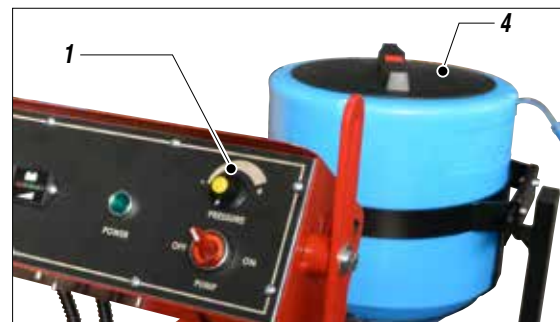


Fig. 4

- Clean the walls of the tank with a brush.
- Turn the pressure adjustment (1) handle slightly clockwise to make the machine function at minimum pressure (*pump activated*).



Fig. 5

- Make sure the re-circulation tube (5) is inserted into a container and wait for clean wash fluid to come out of it.
- Turn the pressure adjustment handle (1) to minimum (*pump stopped*).
- Place the re-circulation tube back into the tank.
- Keep the gun's trigger (2) pressed to release any residual pressure.
- Remove the nozzle from the gun and wash it separately.
- Closed the recirculating-safety valve
- Turn the pressure adjustment handle (1) slightly clockwise to make the machine function at minimum pressure (*pump activated*).
- Point the manual gun (2) into a container (3), drain the residual paint and wait for the wash fluid to come out clean the entire spraying circuit.

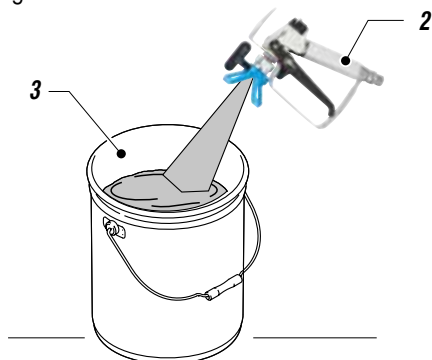


Fig. 6

- Empty all of the wash fluid from the tank and turn off the equipment.
- Turn the pressure adjustment handle (1) to minimum (*pump stopped*).
- In case of long storage, we recommend you to suck and to leave light mineral oil inside the pumping group and the flexible hose.



**Follow the washing procedure before using again the equipment.**

## P GENERAL MAINTENANCE



**Discharge the pressure in the pump unit (*open the discharge valve*) before carrying out any maintenance.**

### DAILY

- Clean the filters;
- Clean the nozzles;
- Clean all the varnish circuit with a specific product;

### PERIODICALLY

- Check the pumping gaskets draft (*if the product draws, replace gaskets*);
- Clean the mobile parts from the varnish deposits (*spray guns, etc.*);
- Check the gun cables tightening, the wheel block;
- Check that the tubes and all the fittings are correctly locked.

## Q BATTERY CHARGE

- Switch off the machine pressing the general switch (1), placed on the side of the control panel.
- Disconnect the battery power cable (2).

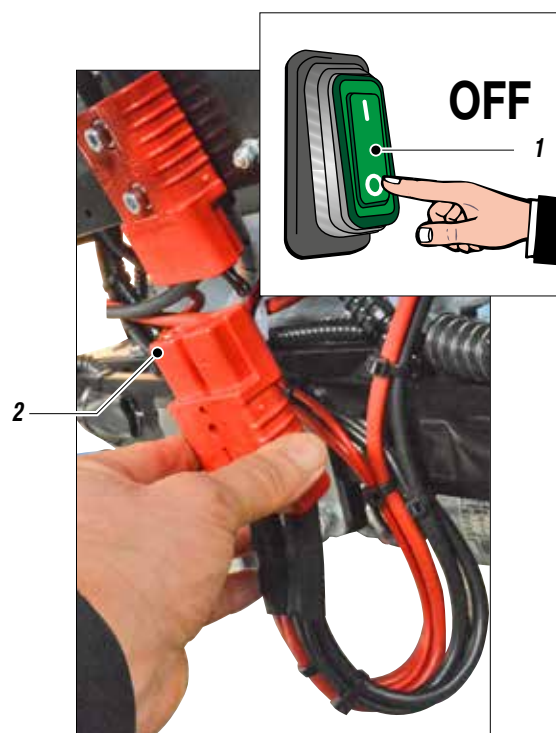


Fig. 1

- Insert the cable (3) of the charger (4).

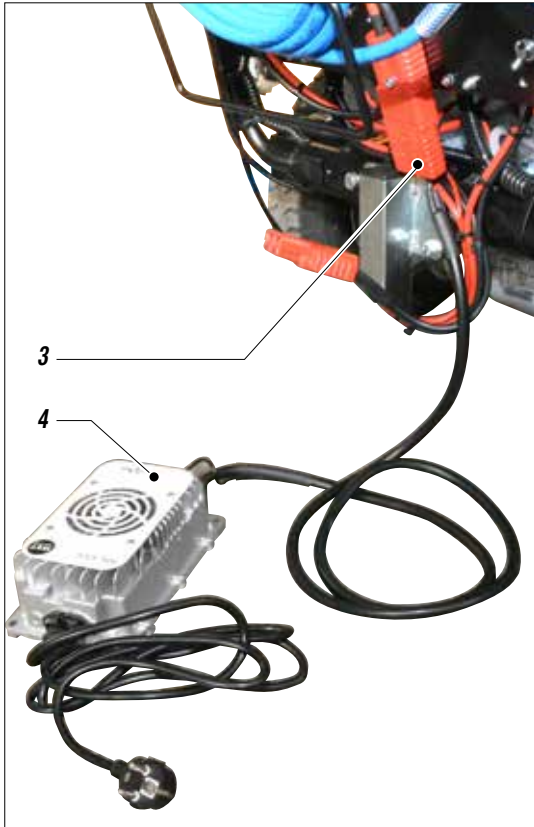


Fig. 2

- Insert the plug (5) into the 220V mains power supply and proceed with a complete charge of the battery.

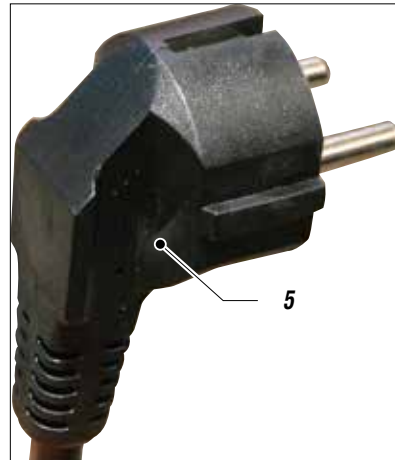


Fig. 3

**NOTE**

*The battery must be charged at least once a month even if the machine is not used.*

## R ROUTINE MAINTENANCE

### OIL CHECK

- Check the motor oil every 50 working hours: top up if necessary.

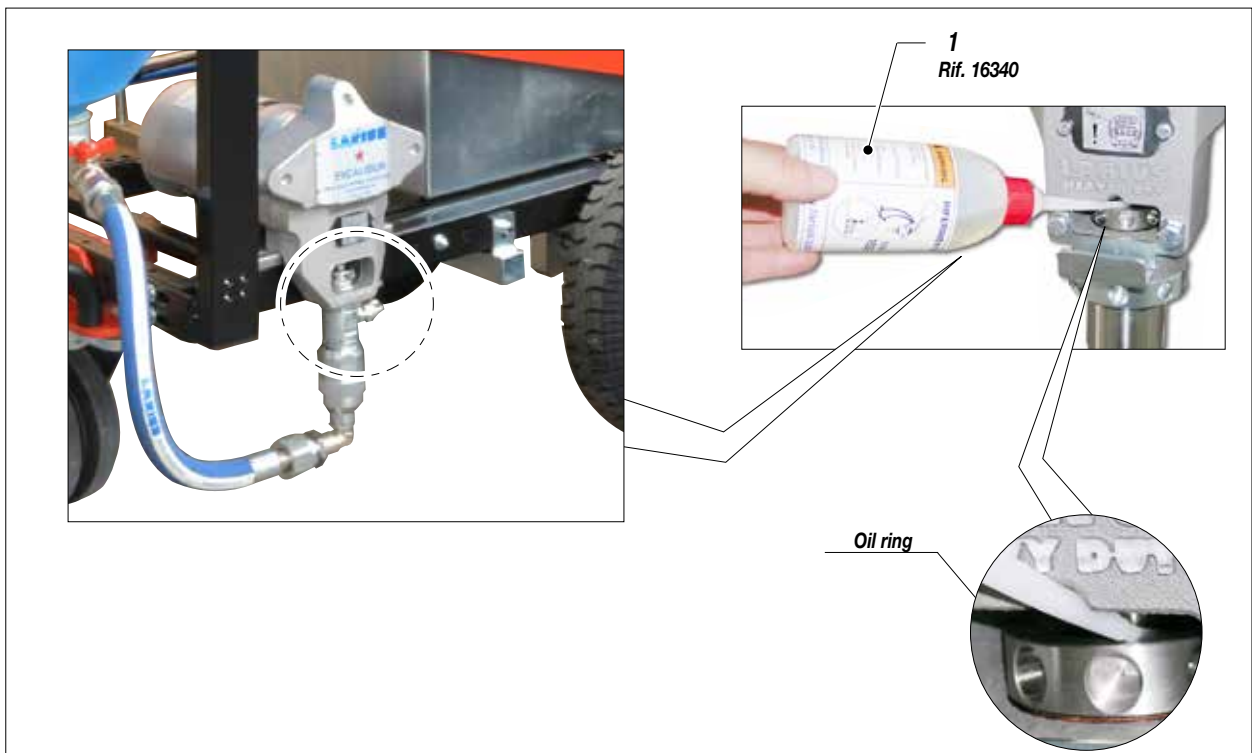


Fig. 1

- For tightening, use the wrench supplied (*ref. 11503*).



Check the packing nut is tight in order to avoid wastes but not excessively to prevent the piston from seizing and the gaskets from wearing.

### CHECK ON THE PACKING NUT

Daily check the packing nut is tight in order to avoid wastes but not excessively to prevent the piston from seizing and the gaskets from wearing.

- Use the lubricant (1) supplied (*ref. 16340*) to allow an easy sliding of the piston inside the gasket group.  
**Daily top up the packing nut.**



At the start of each working day check that the ring nut is full of hydraulic oil (*Ref. 16340*). This oil makes it easier for the piston to slide and prevents any material that escapes via the seal gasket drying when the equipment is stopped.

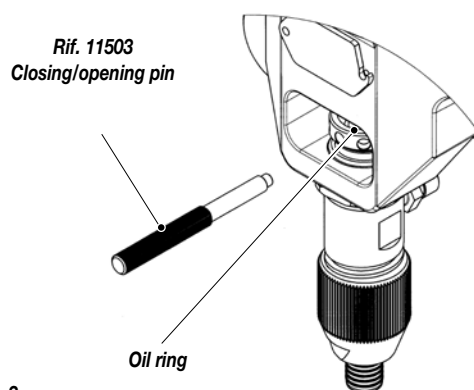


Fig. 2

## S CORRECT PROCEDURE OF DECOMPRESSION

- Move the switch (1) to the **OFF (0)** position to stop the equipment.

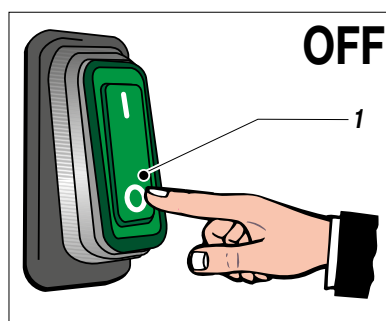


Fig. 1

- Reduce pressure to the minimum (*turn counterclockwise the pressure control knob (2)*).



Fig. 2

- Unlock the safety clamp (3).

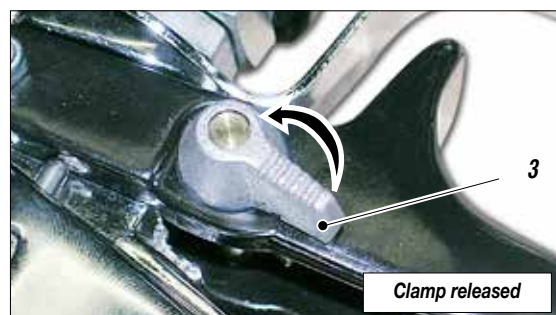


Fig. 3

- Point the gun (4) at the container (5) used to collect the product and press the trigger to release the pressure. When completed, activate the safety clamp again.

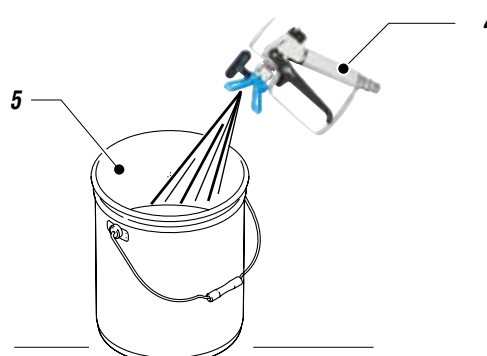


Fig. 4

- Open the recirculating-safety valve (6) to release the remaining pressure.

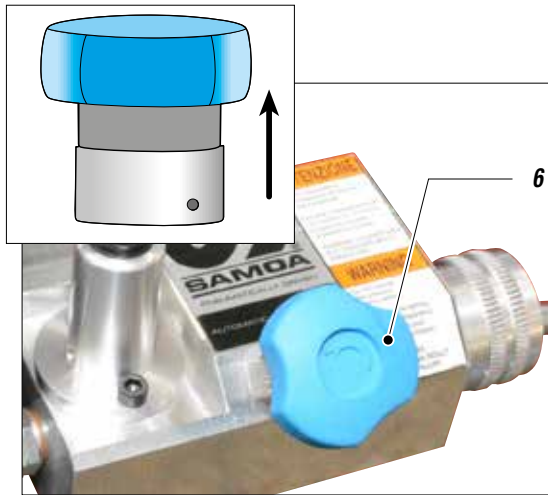


Fig. 5

**WARNING:**

If the equipment is still under pressure after performing the operations above described because of the nozzle or the flexible hose clogged, proceed as follows:



- Loosen very slowly the gun nozzle.
- Release the clamp.
- Point the gun at the container of the product and press the trigger to release pressure.
- Loosen very slowly the fitting of connection from the flexible hose to the gun.
- Clean or replace the flexible hose and the nozzle.

## T REPLACEMENT OF THE PUMPING GROUP'S GASKETS

Each time you use the machine, check for material leaking from the top of the ring nut.

If any material leaks out when the pump is working at the set pressure, proceed as follows:

- Carry out this operation after cleaning the tooling.



Always disconnect the power supply and release pressure before going on with the operations (follow the "correct procedure of decompression"). The gaskets are self-adjusting. If a leak occurs they must be replaced.

- Use a 19 mm spanner to unscrew the ring nut (1) on the feed pipe in order to make the operation easier.

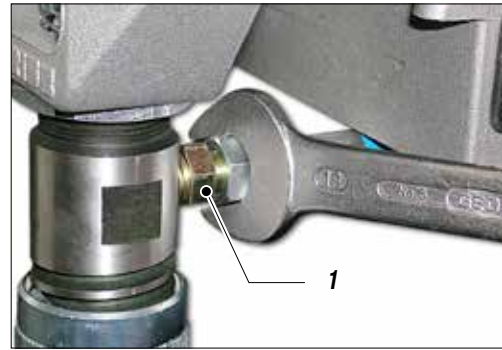


Fig. 1

- Release the plastic covering (2).



Fig. 2

- Run the engine until the piston rod reaches the lower point of its stroke and bring the connecting rod to an accessible position for extraction.
- Remove the locking pin (3) using pliers (4).



Fig. 3

- Unscrew the fixing ring nut (5) to the end of the thread using a 45 mm spanner.



Fig. 4

- Unscrew the suction casing using a 32 mm spanner as illustrated. If necessary, remove the suction pipe (6) before continuing with the other operations.

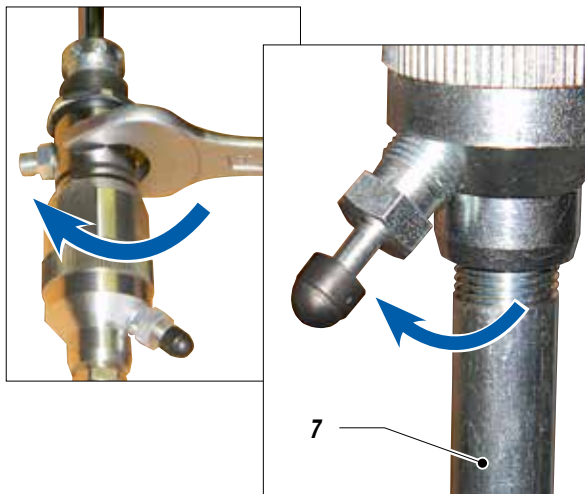


Fig. 5

- Disconnect the pumping group by unscrewing the fastening nut (wrench 45).
- Unscrew the pumping group from the housing.

You can now work easily as the pump casing has been freed.

- Grip the complete pump unit (7) in a vice (8) (as shown).

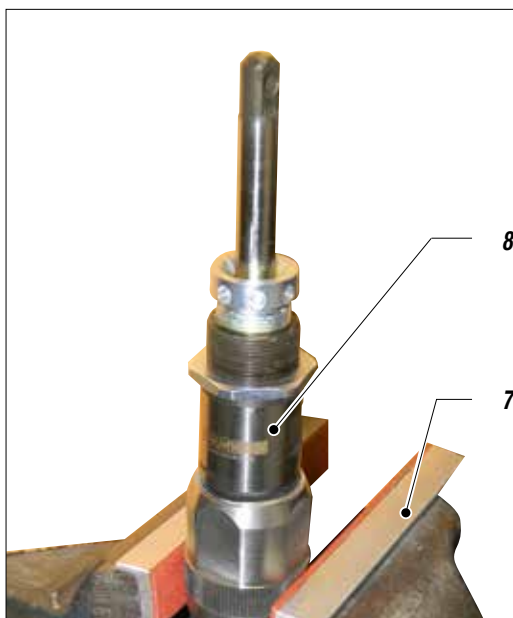


Fig. 6

- Loosen the ring nut (9) by two complete turns with the appropriate pin (10) supplied. Rotate counterclockwise as shown.

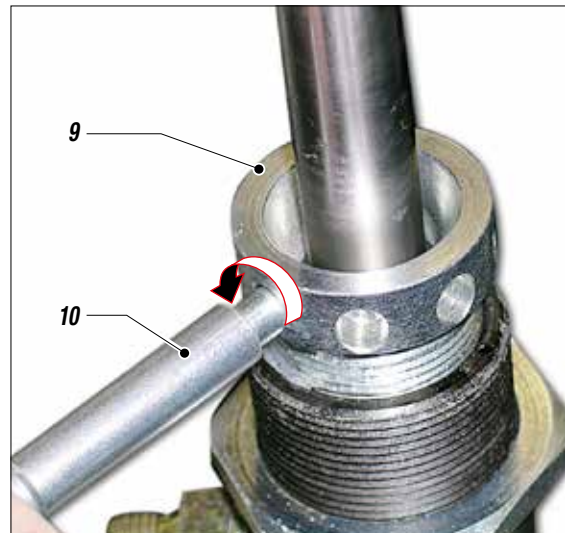


Fig. 4

- Use a 36 mm spanner to unscrew the pump unit as shown.



Fig. 5

- Remove the pump unit (11) from the foot valve (12) as shown. **Inspect the two parts separately.**

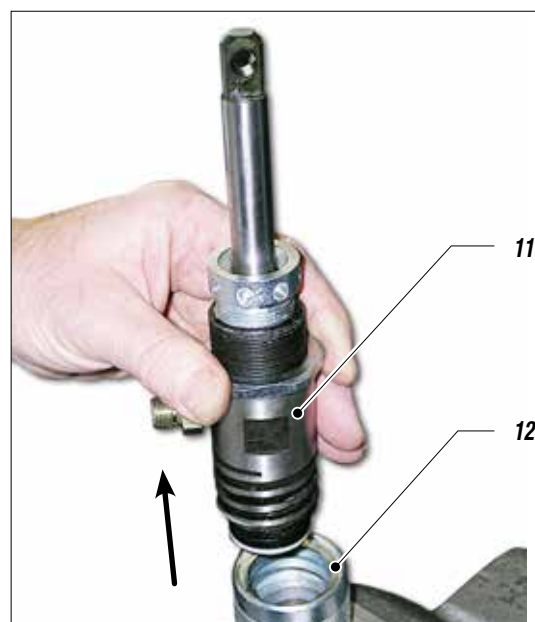


Fig. 6

**PIT STOP MAINTENANCE**

Replacement of upper and lower gaskets 25 minutes.

**REPLACING THE FOOT VALVE SEALS**

- Replace the PTFE gasket (13) located under the ball seating (14).
- Check that the surfaces of the ball seating (145) and the ball (15) are not damaged. If necessary, replace both of them.
- Fit them again using the component sequence shown.

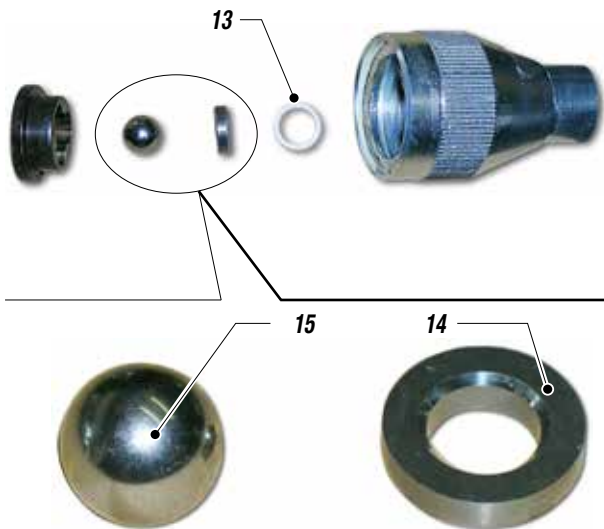


Fig. 7

**REPLACING THE PUMP UNIT HOUSING UPPER GASKET**

- Remove the piston stem (16) from the pump unit housing (17) as shown.



Fig. 8

- Unscrew the gasket compression ring nut (18) completely. **All the gaskets in the unit must be replaced at the same time to allow the machine to work properly.**

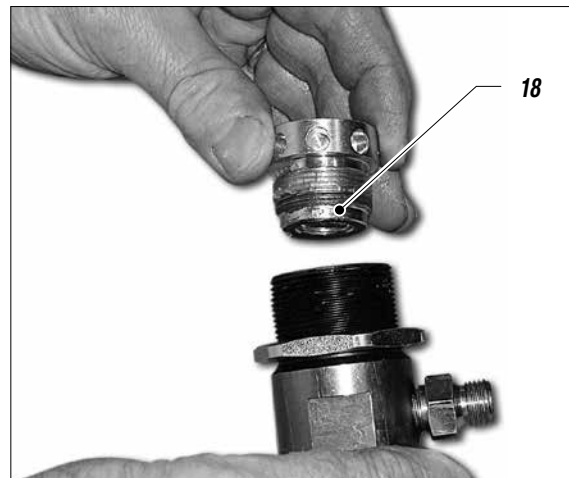


Fig. 9

- Remove the upper stainless steel female ring (19) as shown

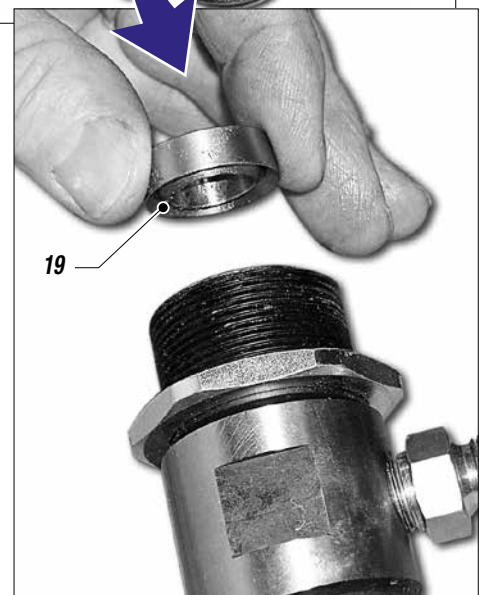
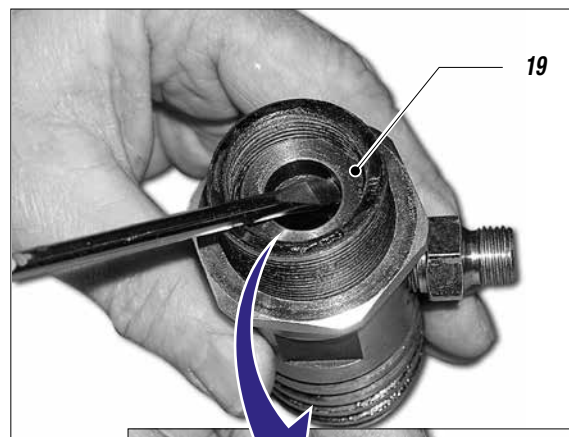


Fig. 10

- Remove the series of gaskets contained inside the pump unit housing, as shown.

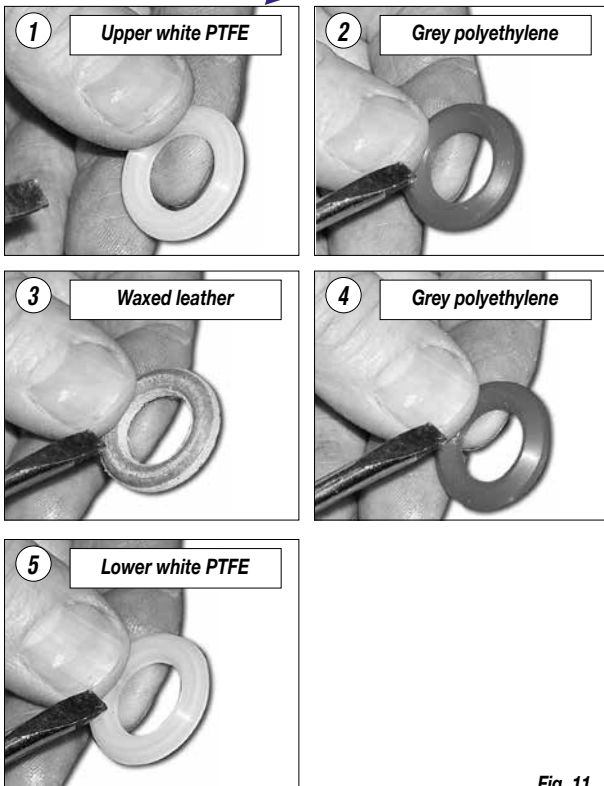


Fig. 11

- Remove the lower stainless steel male ring (20) as shown.



Fig. 12

- Fit the new gasket kit according to the component sequence shown in the figure.

**UPPER**

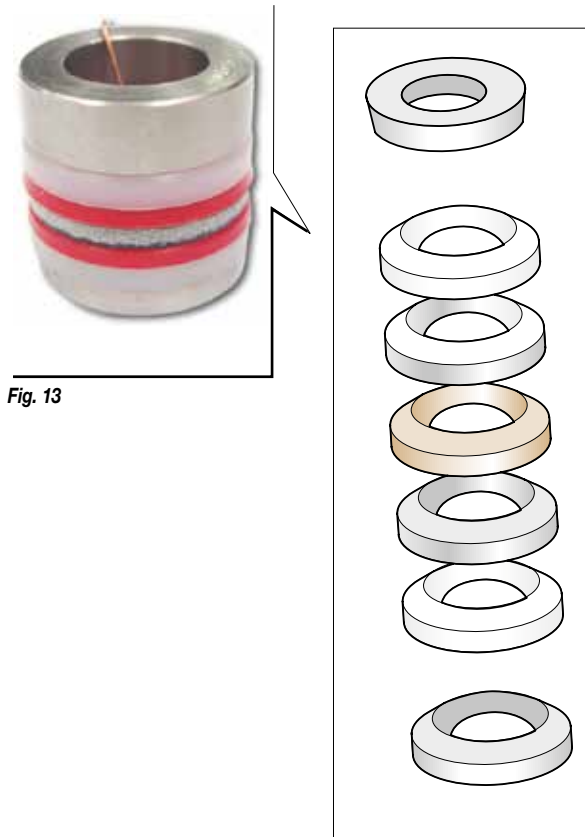


Fig. 13

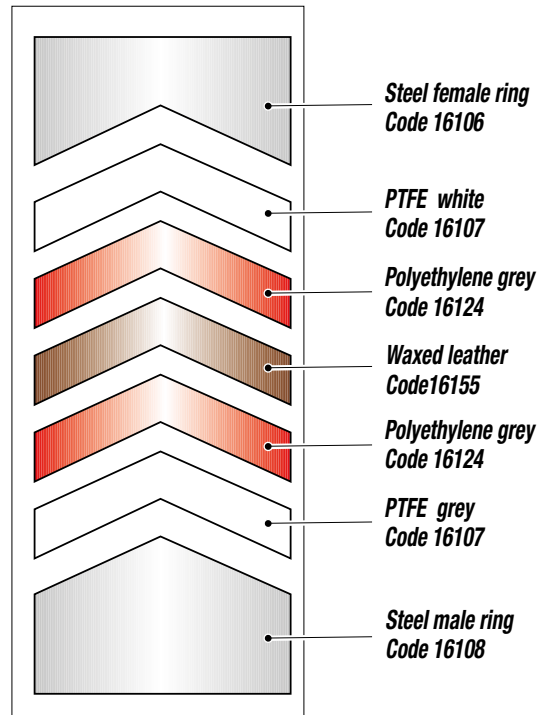


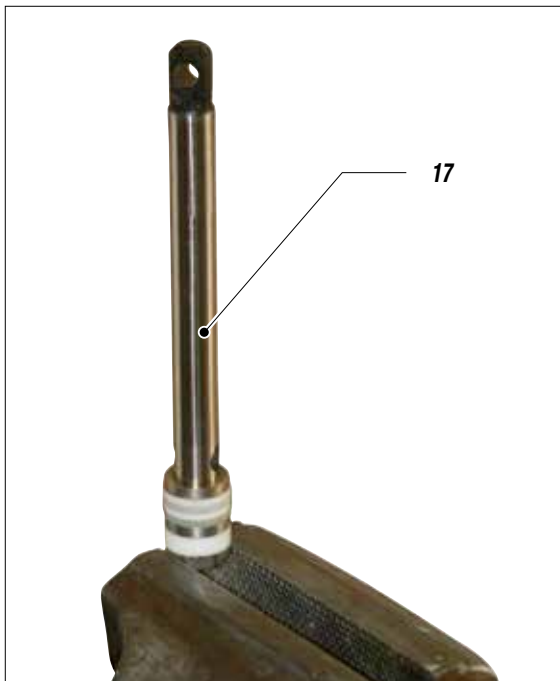
Fig. 14

- Remove the PTFE O-ring (21) and replace it with a new one (22).



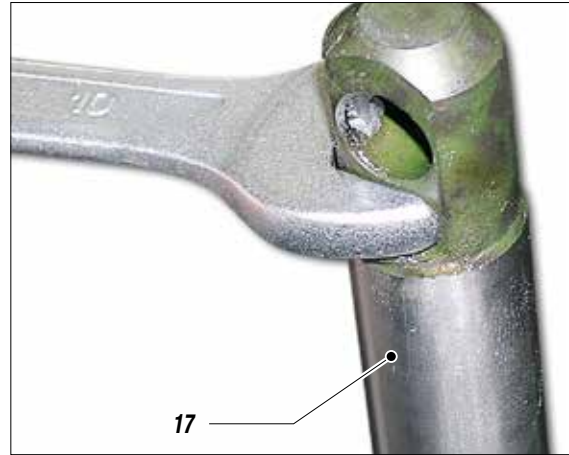
**Fig. 15**  
**REPLACING THE PUMP UNIT STEM GASKET**

- Secure the stem (17) in a vice as shown.

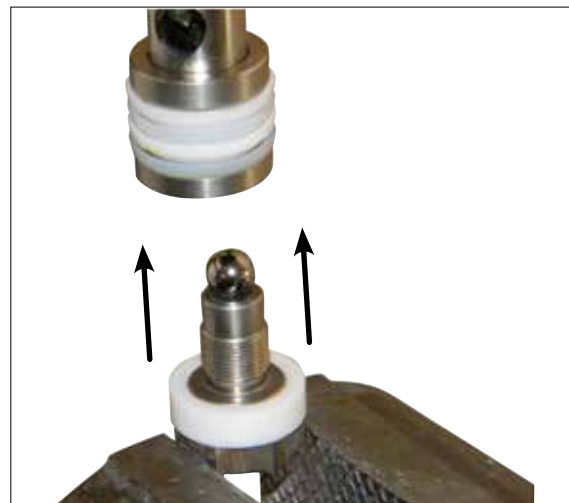


**Fig. 16**

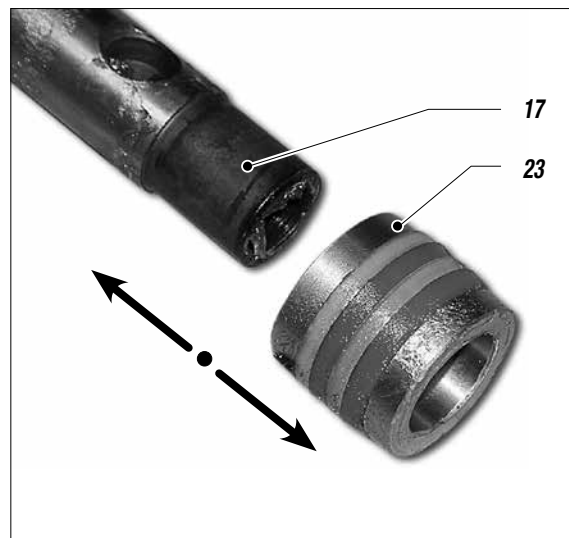
- Use a 10 mm spanner to unscrew and remove the stem (17) as indicated.
- Remove the complete gasket kit (23) from the stem (17), as shown, in order to replace it.



**Fig. 17**



**Fig. 18**



**Fig. 19**

- Fit the new gasket kit according to the component sequence shown in the figure. Check the scraper for wear (Ref. 18648). Replace if necessary.

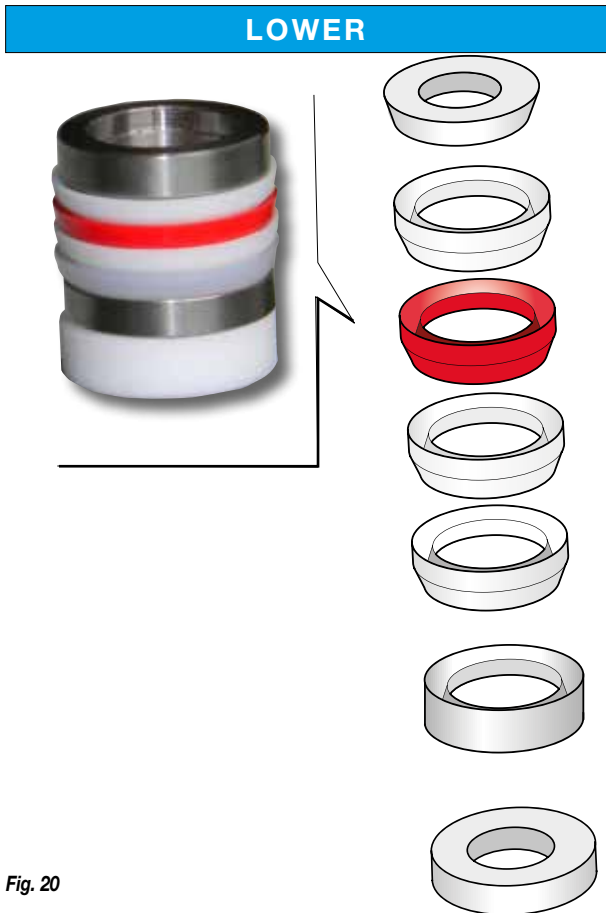


Fig. 20

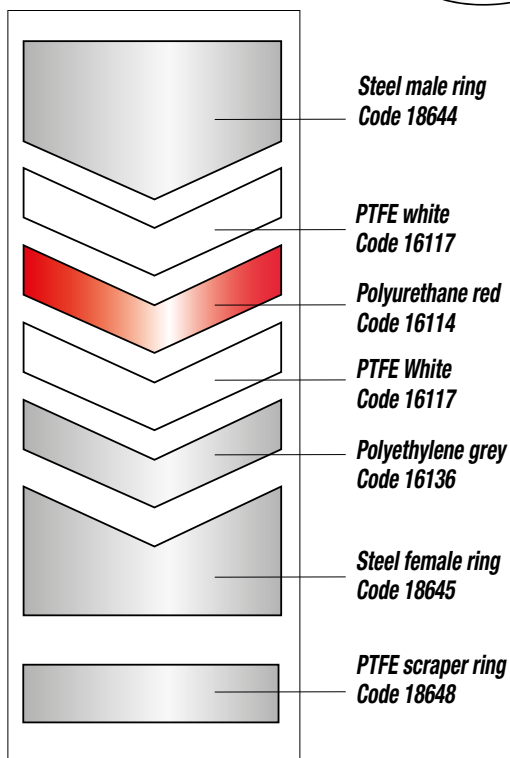


Fig. 21

- Replace the grey polyethylene lipped gasket (24) for the valve piston.
- Refit according to the assembly order and the alignment of the lip (as shown).  
**Check the surfaces of the ball (25) and ball seating (26), and replace both if damaged.**

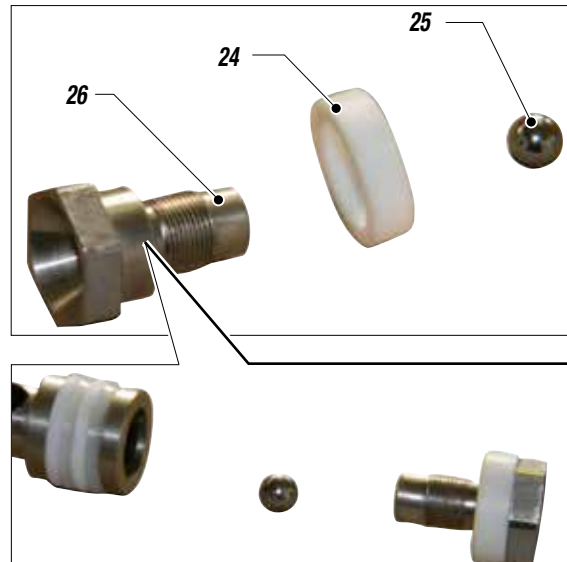


Fig. 22

- Assemble the components as shown.

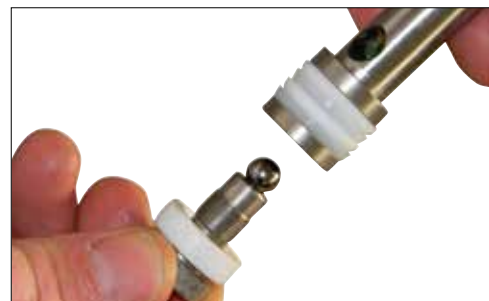


Fig. 23

- Lubricate the gaskets (27) and the stem. Vaseline is recommended for this task.

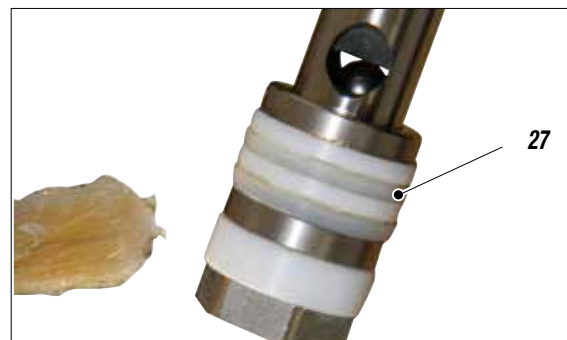


Fig. 24

- Insert the stem (17) into the housing (16) rotating it as you do so in order to allow it to slide more easily and to avoid damaging the upper gaskets.

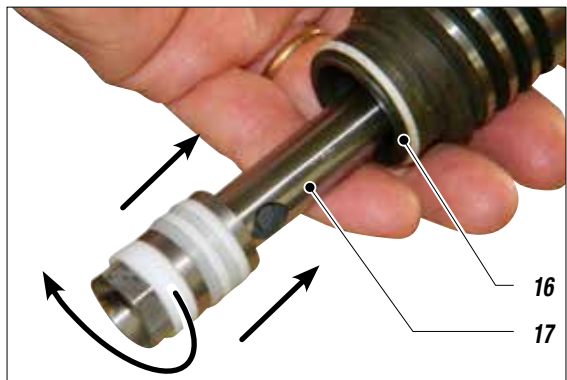


Fig. 25

- Lubricate the O-ring (28) (Ref. 16126) with grease, as shown. Vaseline is recommended for this task.

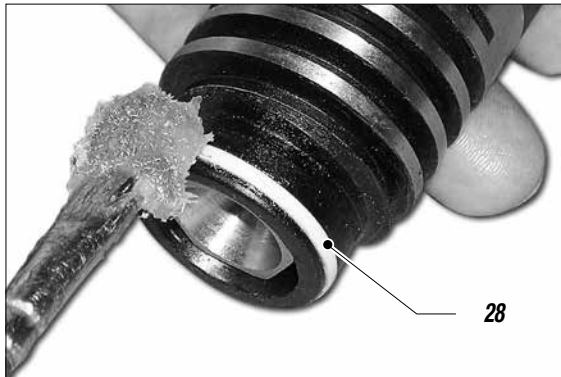


Fig. 26

- Put liquid PTFE on the first two turns (29) and (30) to avoid the two components coupled as shown from unscrewing.

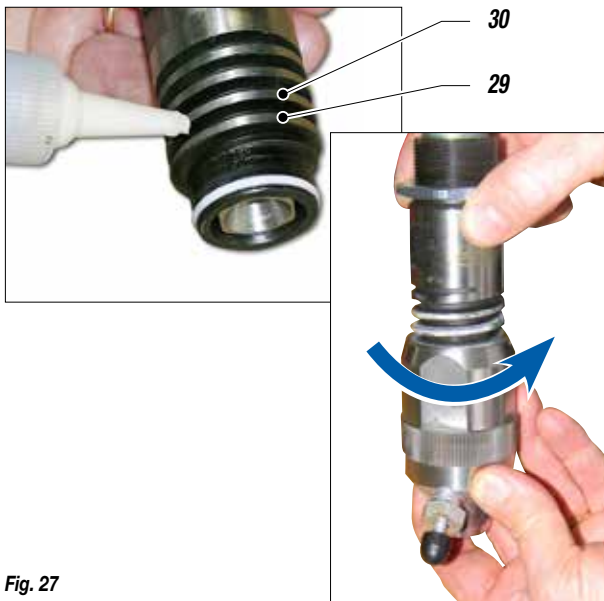


Fig. 27

- Use a 36 mm spanner to screw on the pump unit (8).

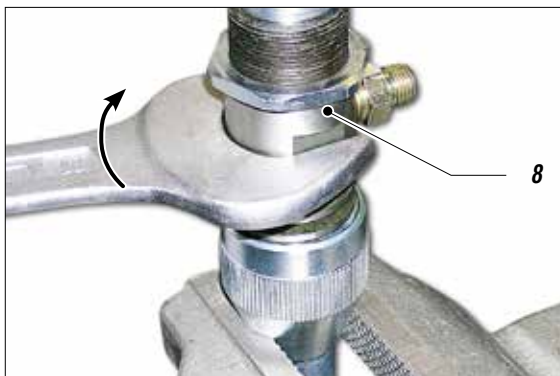


Fig. 28

- Make the piston stem (17) fitted previously complete a full stroke as shown.

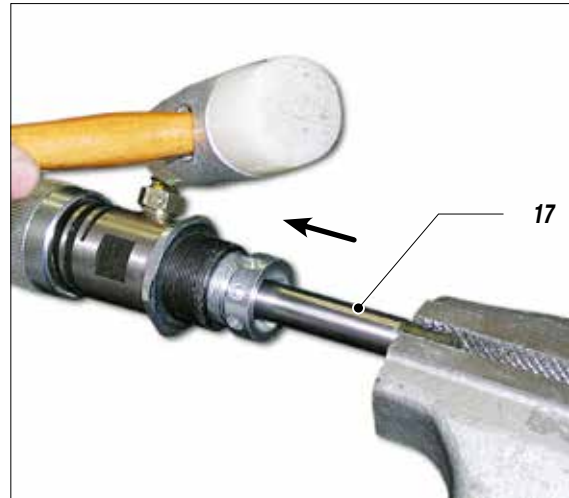


Fig. 29

- Use the pin (10) supplied to tighten the gasket compression ring nut (9). Close this until it is fully touching, without forcing.

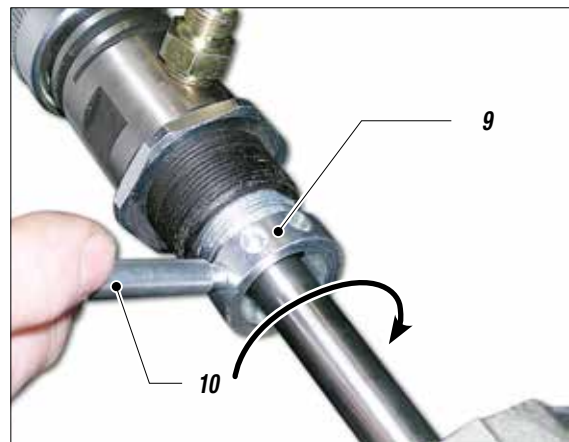


Fig. 30

### CORRECT POSITIONING OF THE PUMP UNIT

Once the unit has been refitted, proceed as follows:

- Check the position of the con rod, which should be positioned at its lower stopping point.
- Put the entire pump unit (8) inside the reduction cover (31) as shown.

- Screw the entire pump unit (8) inside the reduction cover.
- Use a gauge to measure the gap between the base of the template and the start of the tightening groove.



Fig. 31

- Screw the entire pump unit onto the front template, making sure that the end of the stem is centred in relation to the groove in the con rod (32).
- Centre the two holes (con rod + stem) and insert the stopping pin (33) inside the con rod (32).
- Check that the closing spring (34) in the con rod (32) goes into the pin seating when closed (as shown).



Fig. 32

**⚠** The reference value (see drawing) must be 18 mm. The maximum tolerance accepted for correct operation is 21 mm maximum and 16 mm minimum.

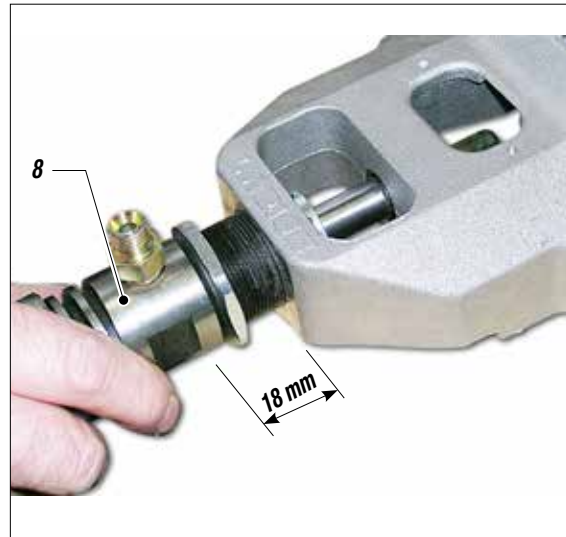


Fig. 33

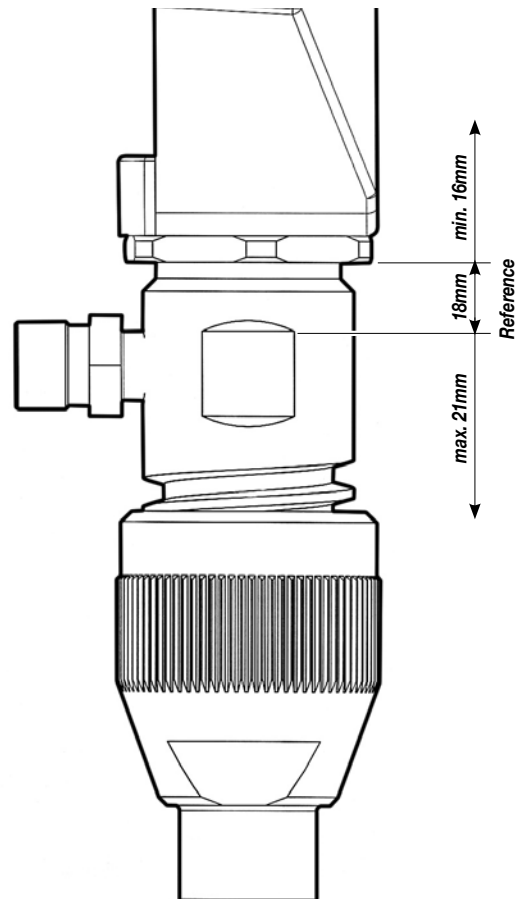


Fig. 34

- Once the unit has been positioned correctly, tighten the lock nut (35) hard against the front template. To tighten, use a 45 mm spanner.

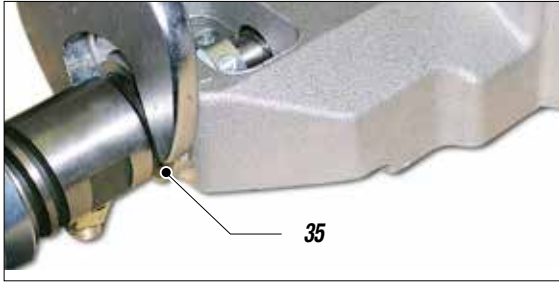


Fig. 35

- Close the inspection cover (2) again.

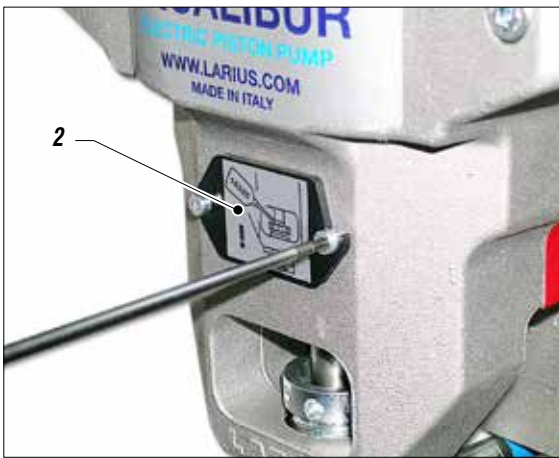


Fig. 36

- Fit the suction pipe. Put PTFE tape or liquid PTFE over the threaded part (36) before screwing it onto the foot valve.

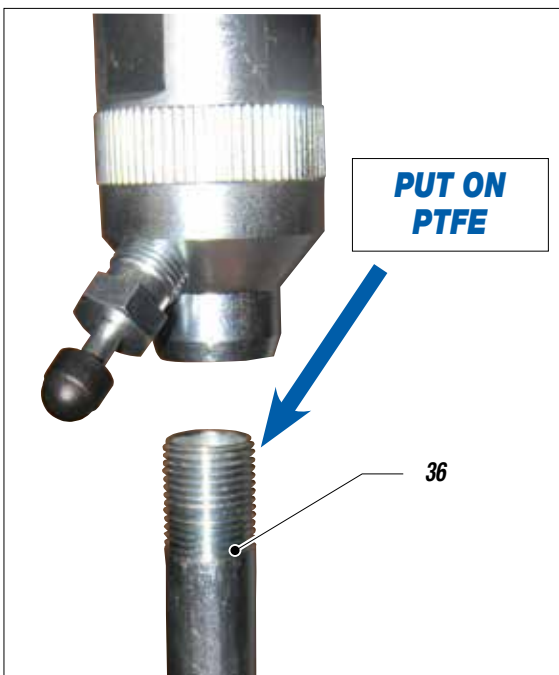


Fig. 37



For correct reassembly, see the exploded diagram for the pump unit, and invert the order used for disassembly.

### REPLACEMENT OF THE BALL RELEASE GROUP SEAL

In case there is a loss of material from the ball release group (37), it is necessary to replace the gasket (38) as shown.



Fig. 38

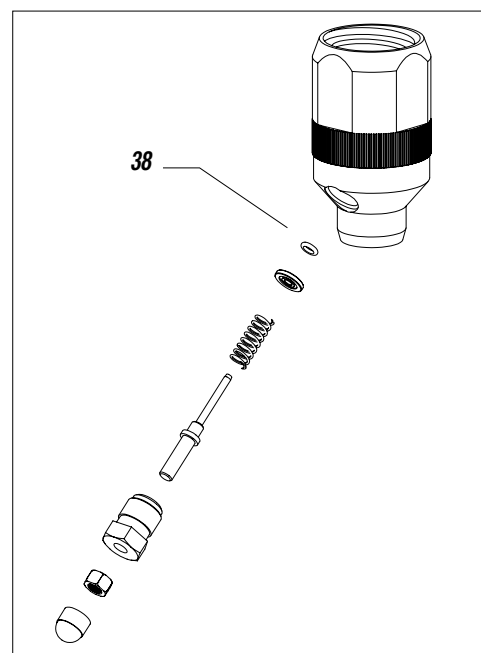


Fig. 39

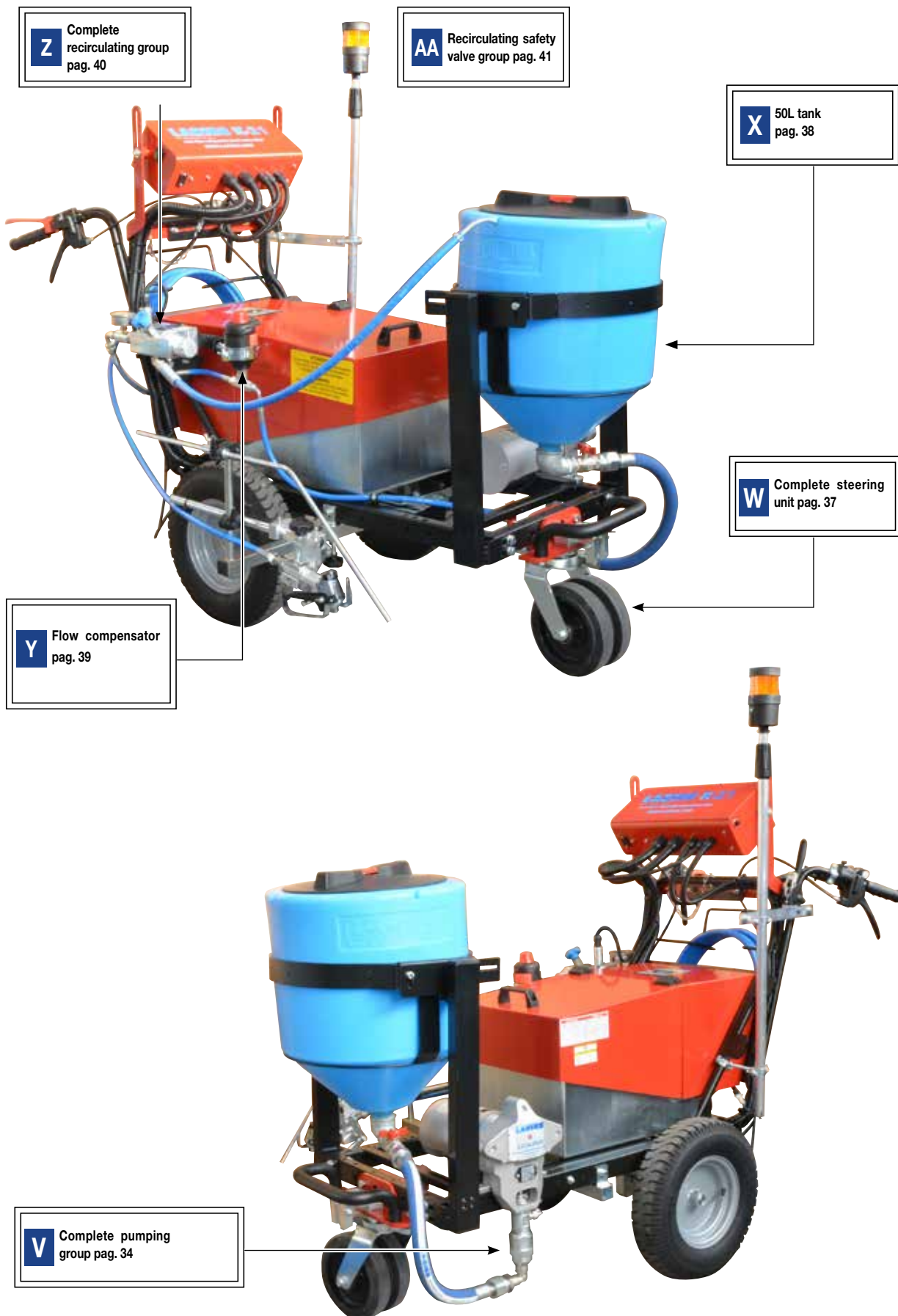
## U PROBLEMS AND SOLUTIONS

Problem	Cause	Solution
<b>The equipment does not start</b>	On/Off switch disconnected;	Ensure the On/Off switch is on the "on" position and turn clockwise the pressure control knob;
	Lack of gasoline;	Add gasoline;
	Breakdown of motor electric control box;	Verify and replace it, if necessary;
	The line of material coming out of the pump is already under pressure;	Open the drain valve to release pressure in the circuit;
	The product is solidified inside the pump;	Open the drain valve to release pressure in the circuit and stop the machine. Disassemble the pumping group and the pressure transmitter and clean;
<b>The equipment does not suck the product</b>	Suction filter clogged;	Clean or replace it;
	Suction filter too fine;	Replace it with a larger-mesh filter (with very dense products, remove the filter);
	Product output valve closed;	Open the product output valve;
	The equipment sucks air;	Check the suction pipe;
<b>The equipment sucks but does not reach the pressure desired</b>	Lack of product;	Add the product;
	The equipment sucks air;	Check the suction pipe;
	The recirculating-safety valve is open;	Close the recirculating-safety valve;
	The gaskets of the pumping group are worn;	Replace the gaskets;
	Suction or delivery valve dirty;	Disassemble the pumping group;
<b>When pressing the trigger, the pressure lowers considerably</b>	Nozzle too big or worn;	Replace it with a smaller one;
	The product is too dense;	Dilute the product, if possible;
	The filter of the gun-butt is too fine;	Replace it with a larger-mesh filter;
<b>The pressure is normal but the product is not atomized Leakage from the seal-tightening screw</b>	The nozzle is partially clogged;	Clean or replace it;
	The product is too dense;	Dilute the product, if possible;
	The filter of the gun-butt is too fine;	Replace it with a larger-mesh filter;
<b>The atomization is imperfect</b>	The nozzle is worn;	Replace it;
<b>When releasing the trigger of the gun, the equipment does not stop (the motor runs slowly and the piston rod keeps on going up and down)</b>	The gaskets of the pumping group are worn;	Replace the gaskets;
	Suction or delivery valve dirty;	Disassemble the pumping group and clean;
	Recirculating-safety valve defective.	Verify and replace it, if necessary.



Always close the air compressed supply and unload the plant pressure before performing any check or replacement of pump parts (see "correct procedure of decompression").

# SPARE PARTS



**Z** Complete recirculating group pag. 40

**AA** Recirculating safety valve group pag. 41

**X** 50L tank pag. 38

**W** Complete steering unit pag. 37

**Y** Flow compensator pag. 39

**V** Complete pumping group pag. 34

# V COMPLETE PUMPING GROUP

**WARNING:** Always indicate code and quantity for each part required.

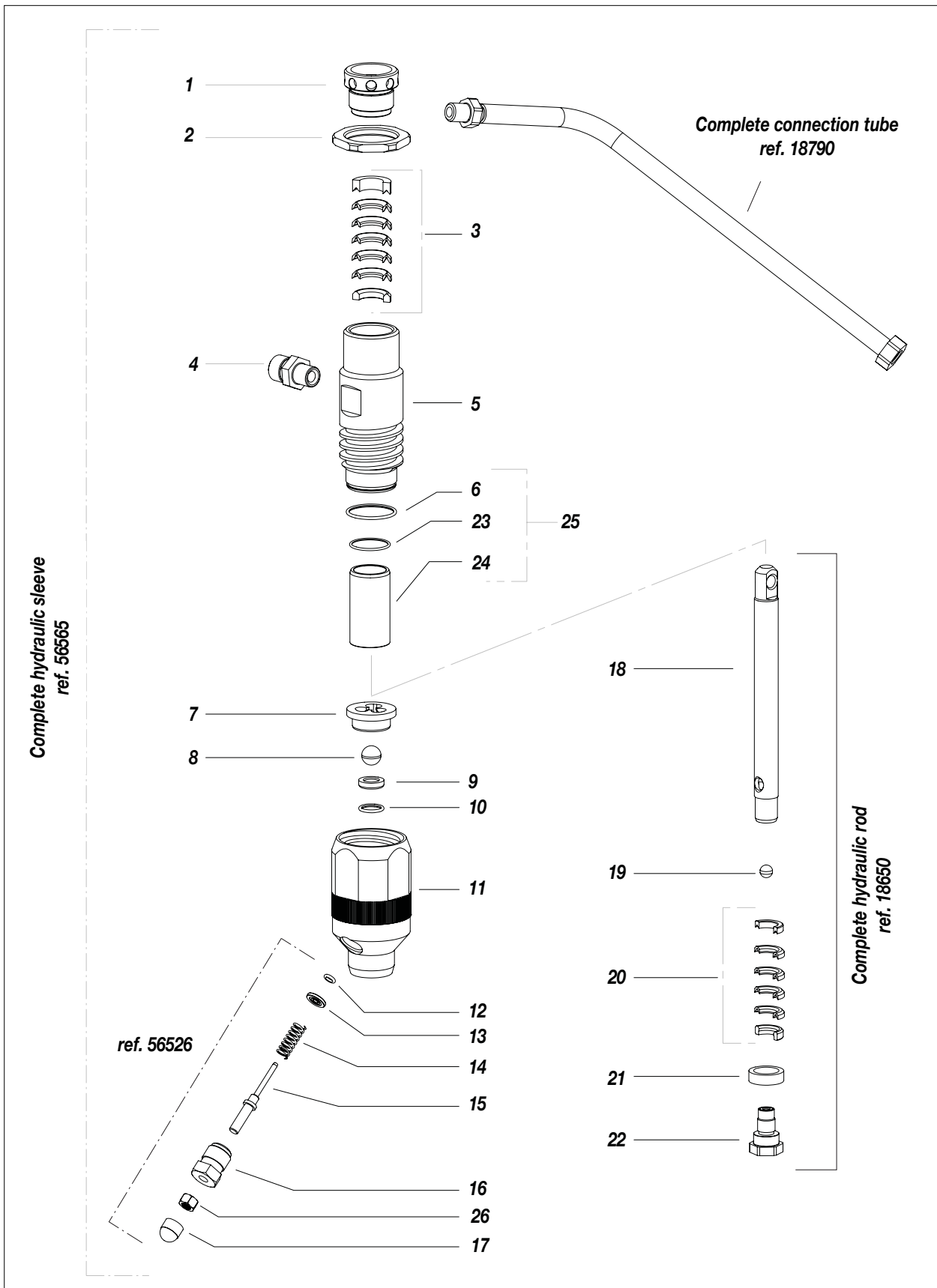


Fig. 1

Pos.	Code	Description
0	56562	Complete hydraulic group
1	16109	Ring packing
2	16127	Locking nut
3	16105	Upper gaskets kit
4	96208/1	Fitting
5	18640	Sleeve
6	16126	OR 2112
7	18642	Ball guide
8	33028	Ball
9	91018	Ball housing
10	18643	Seal
11	56536	Foot valve body

Pos.	Code	Description
12	18553	OR 2012
13	56540	Disk
14	9288	Spring
15	56547	Releasing rod
16	56538	Guiding bushing
17	56541	Rod rubber
18	18652	Piston rod
19	16130	Ball
20	18651	Lower gaskets kit
21	18648	Scraper ring
22	18655	Complete rod valve

40107 : Complete pump repair kits

Pos.	Code	Description
3	16105	Upper gaskets kit
5	18640	Sleeve
6	16126	OR 2112
8	33028	Ball
10	18643	Seal

40106 : Pump maintenance kit

Pos.	Code	Description
3	16105	Upper gaskets kit
6	16126	OR 2112
8	33028	Ball
10	18643	Seal

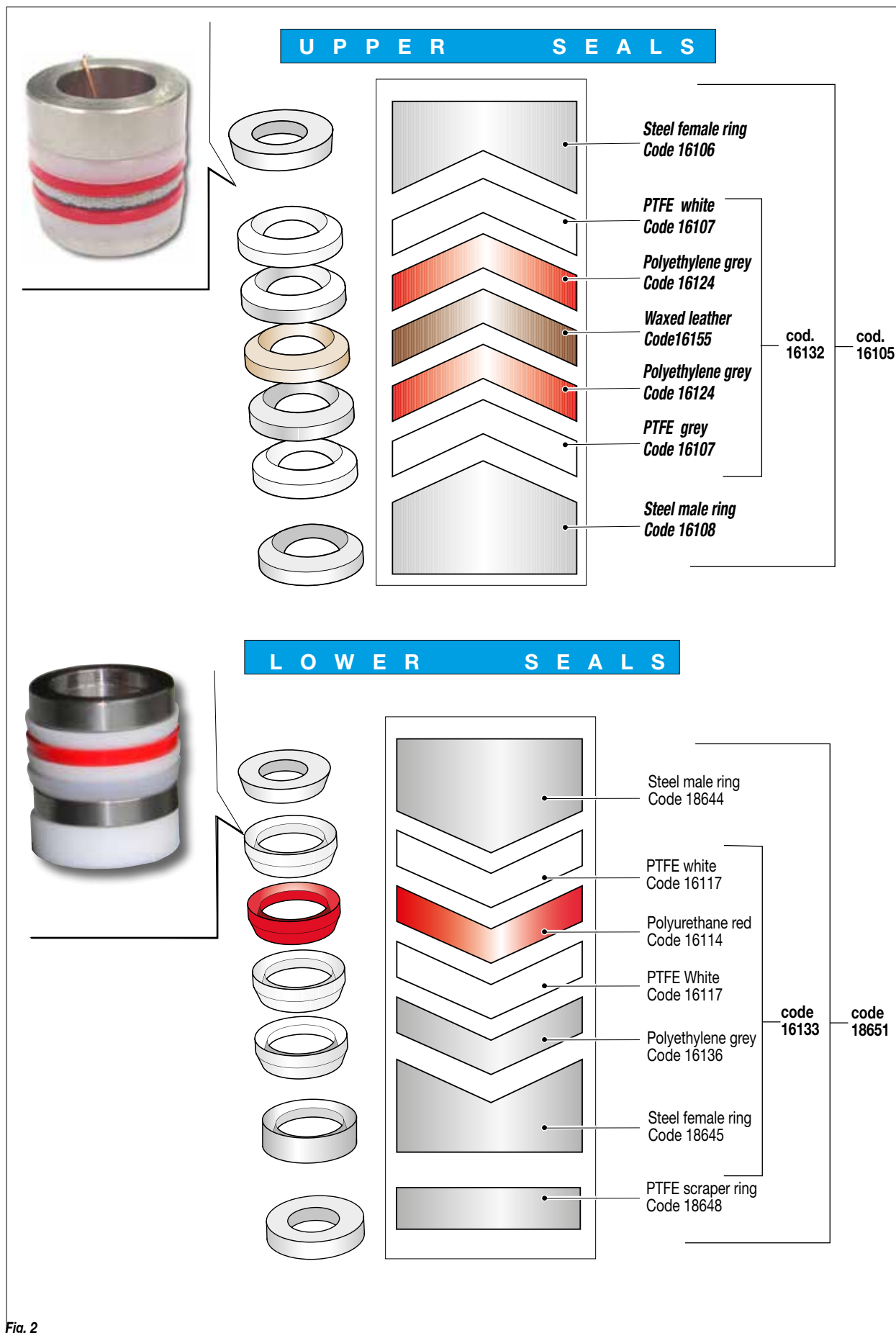
18854 : Foot valve kit

Pos.	Code	Description
8	33028	Ball
9	91018	Ball housing
10	18643	Seal

18855 : Gasket kit lower + higher

Pos.	Code	Description
3	16105	Upper gaskets kit
20	18651	Lower gaskets kit

**GASKETS ASSEMBLY**



## W COMPLETE STEERING UNIT

**WARNING:** Always indicate code and quantity for each part required.

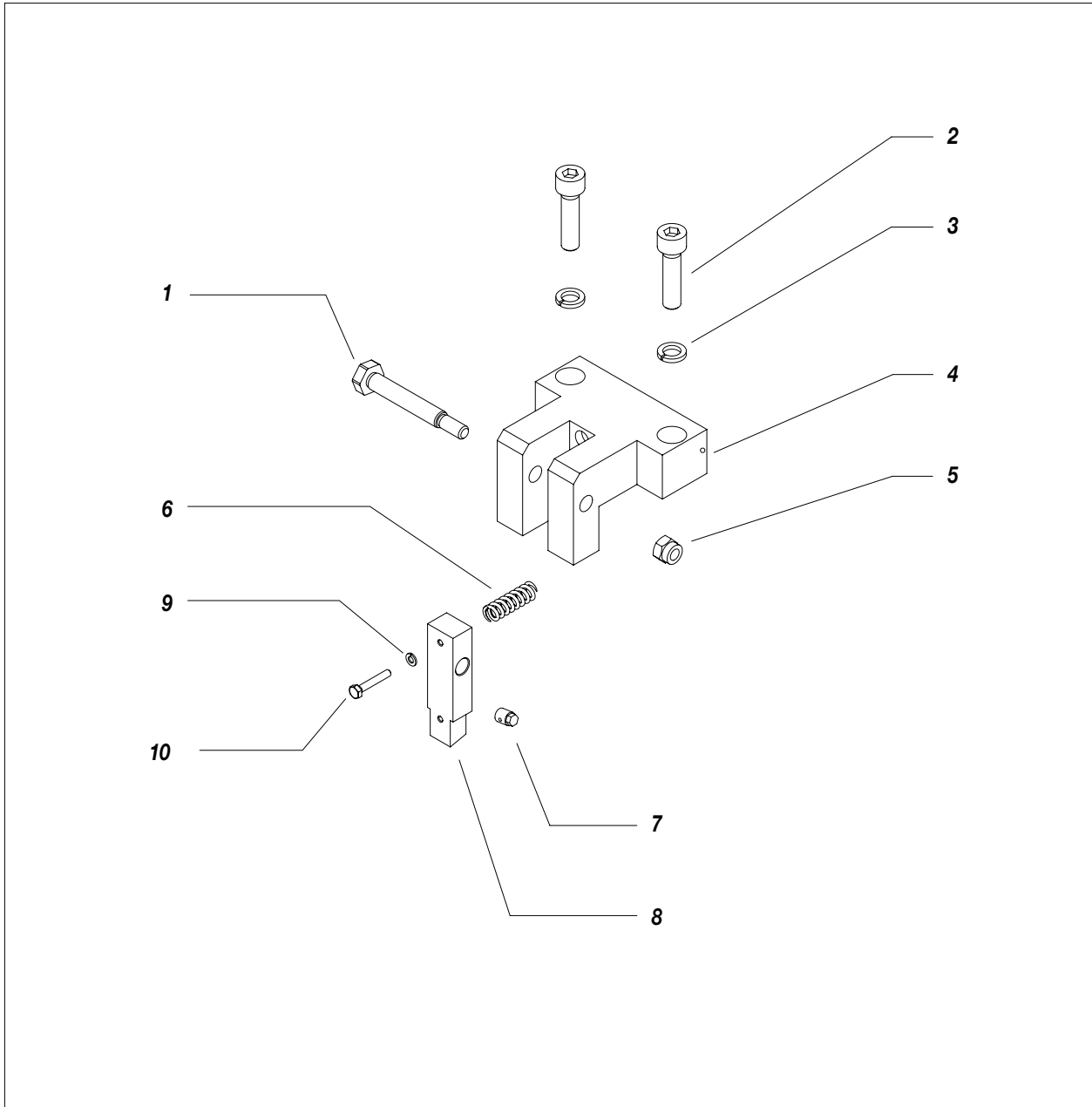


Fig. 1

Pos.	Code	Description
-	4876	Complete steering unit
1	4735	Screw
2	95068	Screw
3	330058	Washer
4	4737	Base
5	3637	Nut

Pos.	Code	Description
6	11205/2	Spring
7	4253	Wire stopper
8	4875	Pin
9	5339	Washer
10	4739	Screw

## X COMPLETE 50L TANK

**WARNING:** Always indicate code and quantity for each part required.

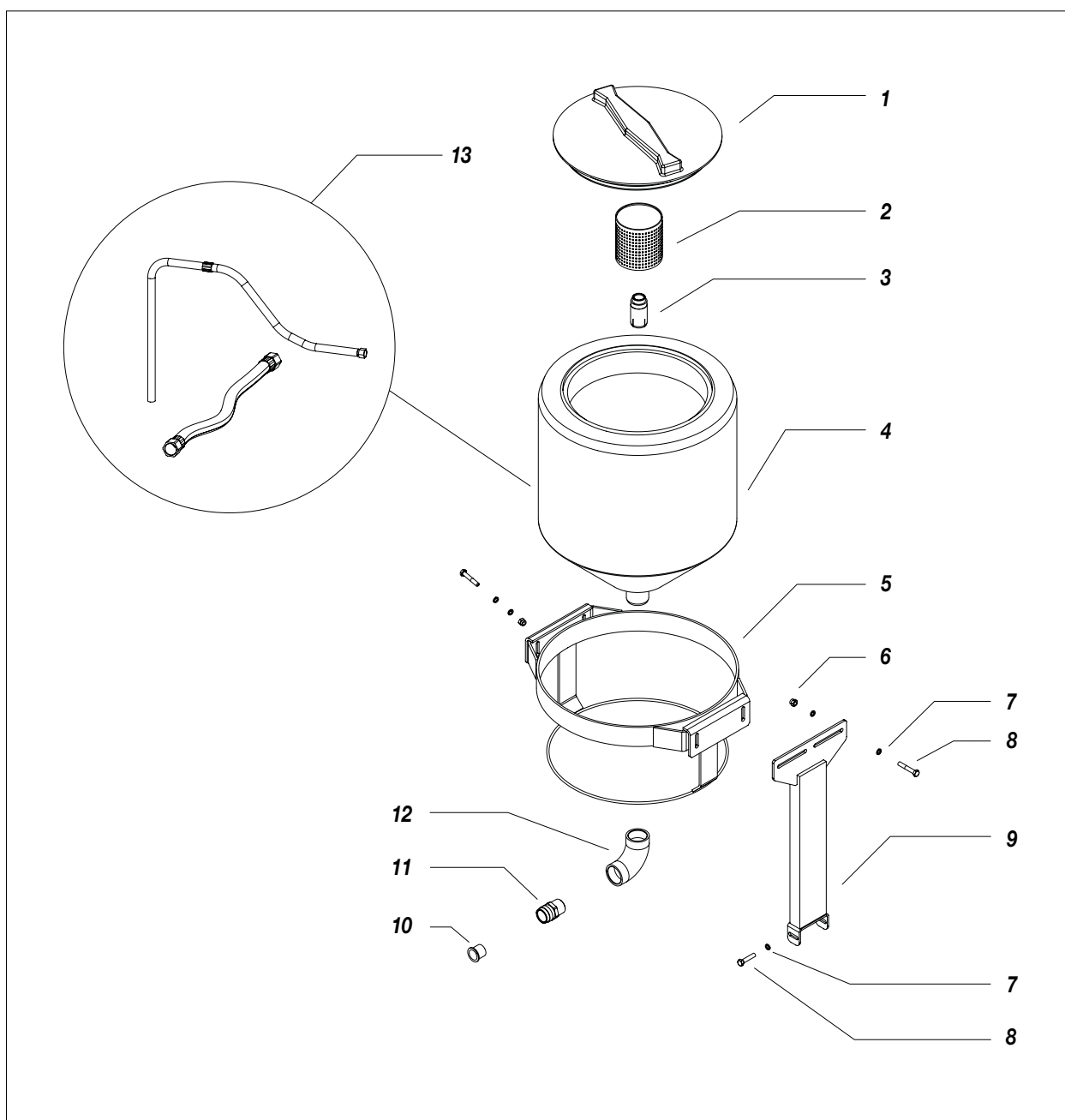


Fig. 1

Pos.	Code	Description
-	4895	Complete 50L Tank
1	18249/1	Cover
2	85014	Filter
3	18231	Support
4	18249	50L Tank
5	18246	Support
6	52017	Nut

Pos.	Code	Description
7	34009	Washer
8	901568	Screw
9	4894	Support
10	96099	Seal
11	95032	Union
12	18215	Elbow
13	16676	Complete suction+output system

## Y FLOW COMPENSATOR

**WARNING:** Always indicate code and quantity for each part required.

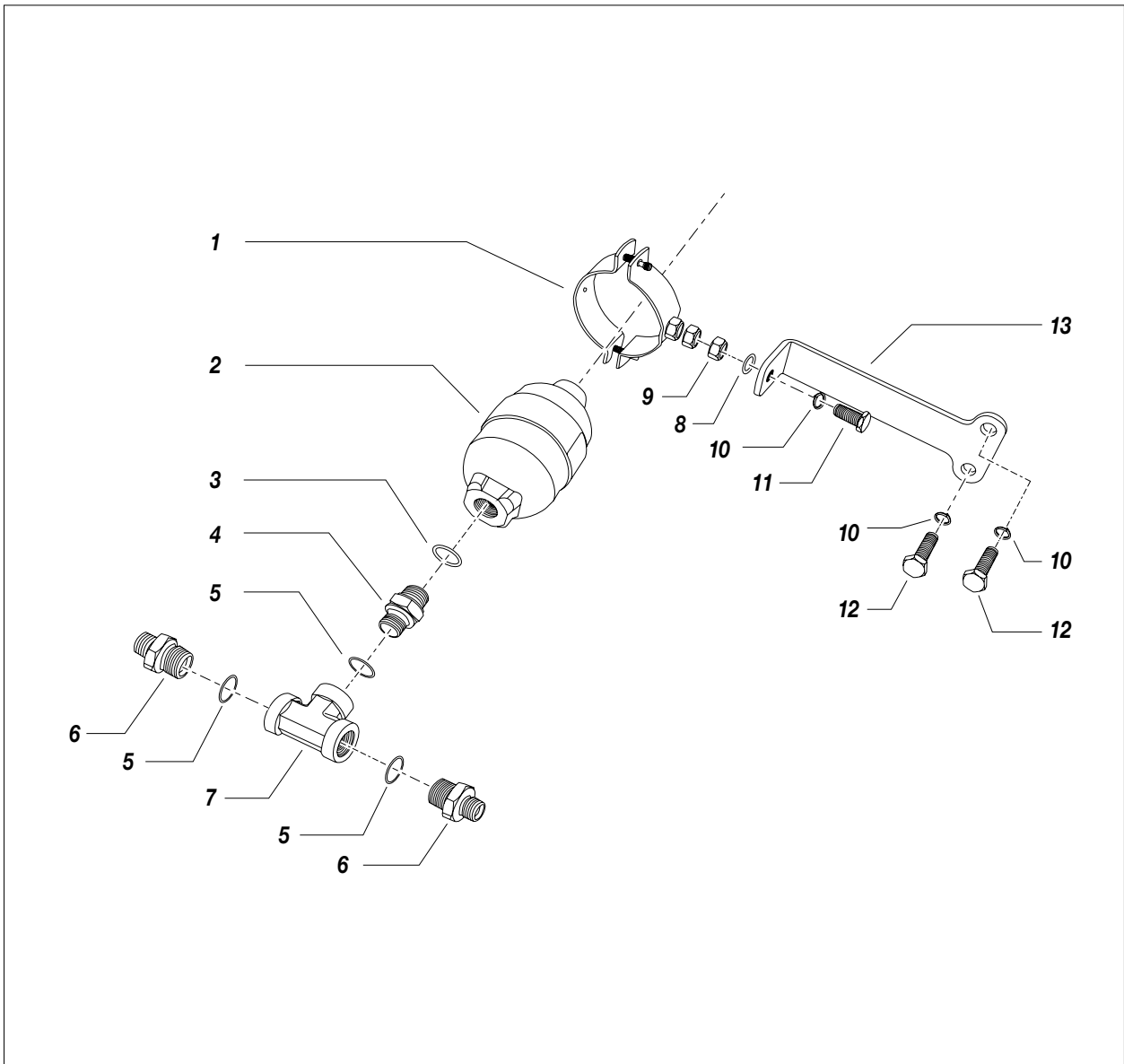


Fig. 1

Pos.	Code	Description	Q. ty
1	4522	Collar	1
2	3372	Flow compensator	1
3	37180	Gasket	1
4	3283	Union	1
5	33010	Gasket	3
6	22022	Union	2
7	8078/1	T fitting	1

Pos.	Code	Description	Q. ty
8	81033	Washer	1
9	96080	Nut	1
10	95096	Washer (Typ Grower)	3
11	4407	Screw	1
12	20560	Screw	2
13	4847	Bracket	1

## Z COMPLETE RECIRCULATING GROUP

**WARNING:** Always indicate code and quantity for each part required.

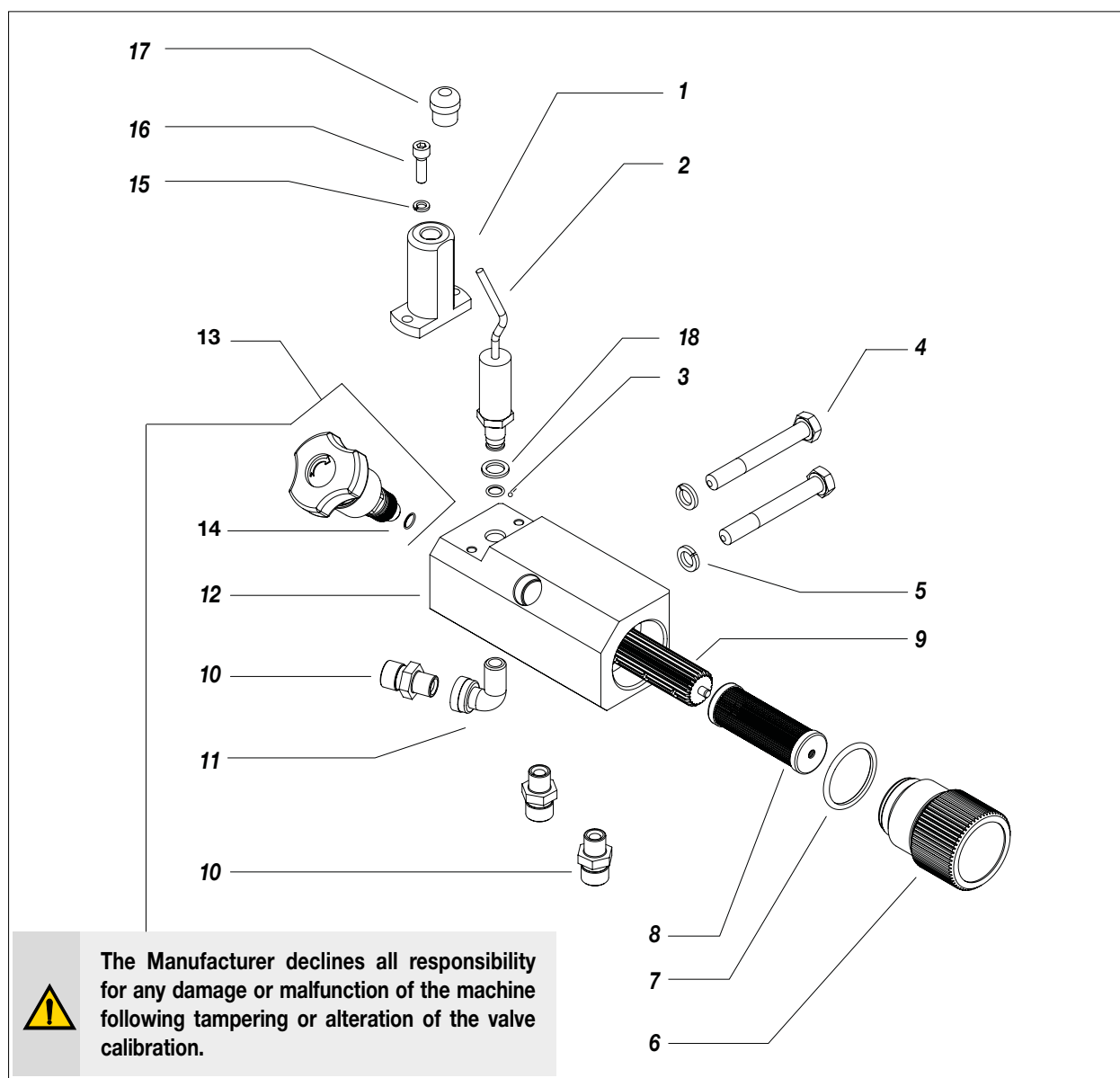


Fig. 1

Pos.	Code	Description
-	4893	Gruppo completo di ricircolo
1	4891	Copertura
2	18692	Sensore P.
3	18689	Tenuta Or
4	33004	Vite
5	33005	Rondella
6	18580	Tappo
7	18622	Tenuta Or
8	16205	Filtro
9	18627	Staccio

Pos.	Code	Description
10	96206	Raccordo
11	18614	Raccordo
12	4892	Base
13	56563	Valvola
14	4033	O-Ring
15	32005	Rondella
16	91062	Vite
17	18871	Pressacavo
18	18684	Guarnizione in rame



## CE DECLARATION OF CONFORMITY



### Company



**LARIUS srl**  
Via Antonio Stoppani 21 - 23801 Calolziocorte (LC) ITALY  
**Tel:** +39 0341 621152  
**Fax:** +39 0341 621243  
**E-mail:** larius@larius.com

Declares under his owns responsibility that the product:

### **ECO K21** **Street marking with battery**

complies with the directives:

- EC Directive 2006/42 Machinery Directive
- EU Directive 2014/30 Electromagnetic Compatibility (EMC)
- EU Directive 2014/35 Low Voltage (LVD)

furthermore to the  
harmonized standards:

- UNI EN ISO 12100-1/-2  
**Machinery safety, basic concepts, general principles of design. Basic terminology, methodology. Technical principles.**

This declaration relates exclusively to the product in the state in which it was placed on the market, and excludes components or modifications which are added or carried out subsequently by end user.

*Signature*

**Pierangelo Castagna**  
Managing Director

Calolziocorte, 22 December 2023  
*Location / Date*



**SAMOA INDUSTRIAL, S.A. - HEADQUARTERS  
SPAIN AND EXPORT MARKETS**

POL. IND. PORCEYO, I-14 - CAMINO DEL FONTÁN, 831  
E-33392 GIJÓN (ASTURIAS), SPAIN  
TEL.: +34 985 381 488 - FAX: + 34 985 147 213

**SAMOA S.A.R.L.  
FRANCE**

P.A.E.I. DU GIESSEN  
3, RUE DE BRISCHBACH  
67750 SCHERWILLER, FRANCE  
TEL.: +33 3 88 82 79 62 - FAX: +33 3 88 82 77 88

**SAMOA ITALIA - LARIUS  
ITALY**

VIA ANTONIO STOPPANI,21  
23801 CALOLZIOCORTE (LC) ITALY  
Tel.: +39 0341 621152 - Fax: + 39 0341 621242

**SAMOA FLOWTECH GMBH**

GERMANY, AUSTRIA, SWITZERLAND, THE NETHERLANDS AND GREECE  
AM OBEREICHHOLZ 4  
D - 97828 MARKTHEIDENFELD, GERMANY  
TEL.: +49 9391 9826 0 - FAX: +49 9391 98 26 50

**SAMOA LTD.**

**UNITED KINGDOM AND REP. OF IRELAND**

ASTURIAS HOUSE - BARRS FOLD ROAD  
WINGATES INDUSTRIAL PARK  
WESTHOUGHTON, BL5 3XP, UK  
TEL.: +44 1942 850600 - FAX: +44 1942 812160

**SAMOA CORPORATION**

USA AND CANADA  
90 MONTICELLO ROAD  
WEAVERVILLE, NC 28787, USA  
TEL. +1 (828) 645-2290 - FAX: +1 (828) 658 0840



©Copyright, SAMOA INDUSTRIAL, S.A.  
SAMOA Industrial, S.A. is an ISO 9001, ISO 14001 and ISO 45001 certified company.

**»» Contact us today!**

Visit [www.samoaindustrial.com](http://www.samoaindustrial.com) for more information.

INSTRUCTION MANUAL AVAILABLE IN:		
	IT	<a href="https://www.larius.com/wp-content/uploads/ECO_K21_I.pdf">https://www.larius.com/wp-content/uploads/ECO_K21_I.pdf</a>
	EN	<a href="https://www.larius.com/wp-content/uploads/ECO_K21_UK.pdf">https://www.larius.com/wp-content/uploads/ECO_K21_UK.pdf</a>