

# LARIUS®

Transfer - Extrusion - Injection pumps - Paint spraying equipment

[www.larius.eu](http://www.larius.eu)

## CH 200 AD



OPERATING AND MAINTENANCE INSTRUCTION



Ediz. 03 - 06/2019



**WE ADVISE THE USE OF THIS EQUIPMENT ONLY BY PROFESSIONAL OPERATORS.  
ONLY USE THIS MACHINE FOR USAGE SPECIFICALLY MENTIONED IN THIS MANUAL.**

Thank you for choosing a **LARIUS S.R.L.** product.  
As well as the product purchased, you will receive a range of support services  
enabling you to achieve the results desired, quickly and professionally.

Due to a constant product improvement programme, the factory reserves the right to modify technical details mentioned in this manual without prior notice.

This manual is to be considered as an English language translation of the original manual in Italian. The manufacturer shall bear no responsibility for any damages or inconveniences that may arise due to the incorrect translation of the instructions contained within the original manual in Italian.











## **POWDER COATING SYSTEM**

<b>I</b> INTRODUCTION .....	p.1	<b>SPARE PARTS</b>	
<b>W</b> WARNINGS .....	p.2	<b>L</b> SHAKING TABLE CH-200-AD .....	p.24
<b>A</b> PRINCIPLE OF OPERATION .....	p.3	<b>M</b> FRAME SPARE PARTS CH-200-AD .....	p.24
<b>B</b> TECHNICAL DATA .....	p.4	<b>N</b> ELECTROPNEUMATIC GENERATOR .....	p.28
<b>C</b> DESCRIPTION OF THE EQUIPMENT .....	p.5	<b>O</b> CH 200 MANUAL GUN REF.9700 .....	p.30
<b>D</b> TRANSPORT AND UNPACKING .....	p.6	<b>P</b> SPARE PARTS FOR AUTOMATIC GUN	
<b>E</b> SAFETY REGULATIONS .....	p.6	CH 200 REF.9705 .....	p.32
Electrical safety regulations .....	p.7	<b>Q</b> SPARE PARTS FOR AUTOMATIC AND MANUAL	
Precautions during work .....	p.7	TRIBO SPRAY GUN .....	p.34
<b>C</b> CONDITIONS OF GUARANTEE .....	p.6	<b>R</b> CONE JET NOZZLE SPRAY GUN FOR CH 200 .....	p.36
<b>F</b> CORRECT USE OF THE SYSTEM .....	p.8	<b>S</b> SPARE PARTS FOR CONE JET NOZZLE WITH	
<b>G</b> INCORRECT USE OF THE SYSTEM .....	p.9	EXTENSION FOR CH 200 .....	p.37
<b>H</b> CONTROL PANEL .....	p.9	<b>T</b> FAN NOZZLE SPARE PARTS FOR CH 200 .....	p.38
Operating controls .....	p.9	<b>U</b> HIGH PERFORMANCE NOZZLE SPARE PARTS	
Current output adjustment $\mu$ a .....	p.11	FOR CH 200 .....	p.39
Connections .....	p.11	<b>V</b> MULTI-DIFFUSION NOZZLE SPARE PARTS	
Operation .....	p.13	FOR CH 200 .....	p.40
Use with CH spray gun (corona effect) .....	p.13	<b>Z</b> POWDER DELIVERY PUMP SPARE PARTS	
Use with triboelectric spraying gun .....	p.15	REF.5505 .....	p.41
<b>L</b> CYCLICAL ROUTINE MAINTENANCE .....	p.16	<b>Y</b> ACCESSORIES .....	p.42
<b>J</b> COLOR CHANGE .....	p.18		
<b>K</b> PROBLEMS AND SOLUTIONS .....	p.19		



## WARNINGS

The meanings of the symbols used in the manual that concern use as well as use, maintenance and repair operations of this machine are described in the following table.

	<p>Carefully read this manual before using the machine.          Improper use may cause damage to persons or property.          Do not use the spray gun if you are under the influence of drugs or alcohol.          Do not modify the spray gun for any reason.          Use products and solvents that are compatible with the different parts of the spray gun, carefully reading the manufacturer's warnings.          Refer to the Technical Data of the spray gun in this manual.          Check the spray gun daily; if worn parts are noted, replace them using <b>ONLY</b> original spare parts.          Keep children and animals away from the work area.          Observe all safety regulations.</p>
	<p>This symbol signals the risk of injury or serious damage to the machine if the warning is not heeded.</p>
 	<p>These symbols signal the risk of chemical reactions and the risk of explosion if the warning is not heeded.          There is a danger of serious injury caused by contact with the spray gun jet, if injury occurs <b>IMMEDIATELY</b> seek medical care, specifying the type of product injected.          Do not spray without having installed the nozzle guard and the spray gun trigger guard.          Do not place fingers on the spray gun nozzle.          At the end of the work cycle and before performing any maintenance operation, follow the pressure relief procedure included in this manual.</p>
	<p>This symbol signals important instructions and recommendations for the environmentally-friendly disposal or recycling of a product.</p>
	<p>This symbol signals the risk of electric shock if the warning is not heeded and the presence of electric voltage.          Store in a place with no humidity and do not expose to rain.          Check to make sure the cables are intact.          Switch off the machine and discharge any residual voltage supply before performing cleaning and maintenance operations.</p>
	<p>This symbol signals the presence of a terminal with a grounding cable.          Use <b>ONLY</b> three-wire extensions and electrical outlets with grounding connections.          Before beginning work, make sure the electrical system is equipped with a grounding connection and that it complies with the safety regulations.</p>
   	<p><b>FIRE AND EXPLOSION HAZARD</b>          Flammable fumes, like solvent and paint fumes can ignite and may explode.          To prevent fire or explosion:</p> <ul style="list-style-type: none"> <li>- Use the machine <b>ONLY</b> in well-ventilated areas.</li> <li>- Eliminate all possible sources of ignition; such as pilot lights, cigarettes, flashlights, synthetic clothing (potential static arc), etc.</li> <li>- Ground the machine and all conductive objects in the work area.</li> <li>- Only use airless conductive tubes that are grounded.</li> <li>- Do not use trichloroethane, methylene chloride, other halogenated hydrocarbon solvents or fluids containing such solvents in aluminium devices that are under pressure. This may cause a dangerous chemical reaction that may could result in an explosion.</li> </ul> <p>If electric charges or shocks are detected <b>immediately interrupt the operation</b> you are performing with the machine.          Keep a fire extinguisher in the immediate vicinity of the work area.</p>



	<p><b>DANGER OF HIGH PRESSURE FLUID INJECTION</b></p> <p>The high pressure fluid that comes out of the spray gun or from any leaks may penetrate the skin and cause lacerations. To prevent fire or fluid injection:</p> <ul style="list-style-type: none"> <li>- Enable the spray gun's trigger safety lock when not spraying.</li> <li>- Do not place hands or fingers on the nozzle of the spray gun. Do not try and stop leaks with your hands, body or other.</li> <li>- Do not point the spray gun towards yourself or anyone else.</li> <li>- Do not spray without the special nozzle guard.</li> <li>- Discharge the pressure of the system after spraying and before performing any maintenance operations.</li> <li>- Do not use components whose operating pressure is less than the maximum pressure of the system.</li> <li>- Do not allow children to use this machine.</li> <li>- Be careful of the possible backlash when you pull the spray gun trigger.</li> </ul> <p>If the high pressure fluid penetrates the skin, the wound may seem like a "simple cut" but, in reality, it could be a very serious injury. Immediately provide medical treatment to the affected area.</p>
	<p>These symbols signal the obligation to wear protective gloves, goggles and masks. Wear clothing that complies with safety regulations in force in the country of the user. Do not wear bracelets, earrings, rings, chains or other objects that may obstruct the operator's work. Do not wear clothing with large sleeves, scarves, ties or any other item that can become tangled in the moving parts of the machine during the operating cycle and inspection and maintenance operations.</p>

## A PRINCIPLE OF OPERATION

This type of machine constitutes a complete and independent unit for the application of powder coatings.

**LARIUS** has created this **AD CH 200-TRIBO** unit which allows the use of **corona effect** spray guns (*the powder is charged by electrodes*), and **triboelectric** spray guns (*the charge occurs via friction*).

Therefore the same machine can be used as an electrostatic generator for **CH 200** series spray guns, or as a control unit for the electrostatic charge for **LARIUS TRIBO** manual and

automatic spray guns.

The conversion from one system to the other occurs via the simple touch of a switch.

The AD version is the ideal solution when frequent colour changes are required. As a matter of fact, the powder is sucked up directly by the original package. If necessary just replace the box with the powder and clean the suction tube.



## B TECHNICAL DATA

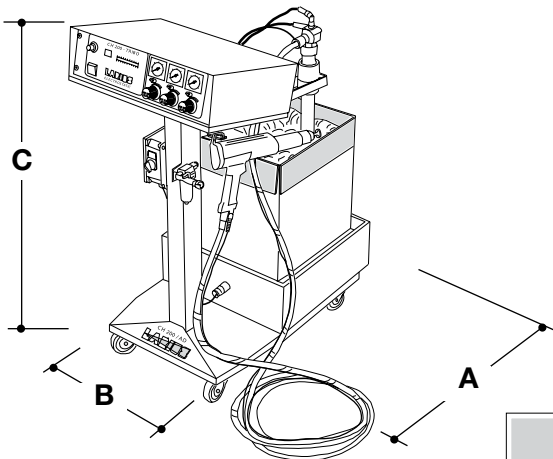

	CH 200 - TRIBO /AD
SUPPLY VOLTAGE	120-220 Vca
INSTALLED POWER	60 W
FREQUENCY	50 Hz
POWDER FLOW	3-20 kg/h
WEIGHT	55 Kg
LENGTH	(A) 490 mm
WIDTH	(B) 800 mm
HEIGHT	(C) 1100 mm

	SPRAY GUN CH 200	SPRAY GUN TRIBO
SUPPLY VOLTAGE	approx. 12 V	-
OUTPUT VOLTAGE	0-120 KV c.c.	-
NOMINAL CURRENT	0-190 µA	-
POLARITY	Negative	Positive
WEIGHT	690 g	590 g
LENGTH	360 mm	450 mm

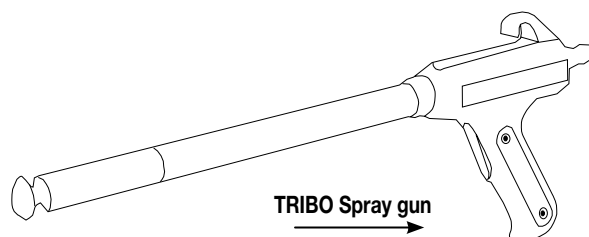
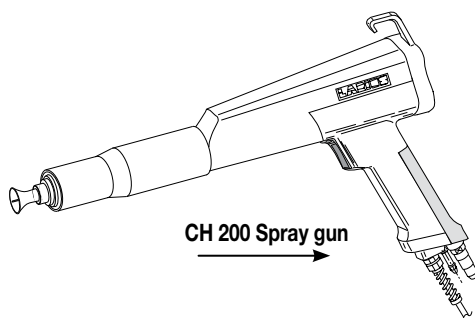



## **C** MAIN PARTS



REP.	Description
1	RACK electrostatic generator which encloses all the power and control circuits, both electrical and pneumatic, as well as the safety systems, and digital display of operating voltage and current.
2	Powder supply tube.
3	Power supply cable for manual spray gun.
4	Support trolley with rotating wheels.
5	Interchangeable powder container for using different colour powders ( <i>max. recommended capacity 25 kg</i> ).

REP.	Description
6	CH200 powder spray gun, composed of a black of epoxy resin cast under pressure and treated with resins for total safety during operation. The voltage multiplier protected by insulating resins is housed inside the body of the spray gun ( <i>which can be used with CH 200 - TRIBO triboelectric spray guns</i> ).
7	Vibrating shaking table with inclined surface, complete with electric vibrator.
8	Switch for electric vibrator



## D TRANSPORT AND UNPACKING

- Carefully observe the position of the packaging indicated on the outside by writing or symbols.
- Before installing the machine, prepare an area that is suitable in size, has the correct lighting, and a clean and smooth floor.

	<p>All operations of unloading and handling of the machine are the responsibility of the user, who must be very careful to avoid causing damage or injury to persons or the machine.</p> <p>Only specialised and qualified personnel (<i>forklift drivers, crane operators, etc.</i>) and suitable lifting equipment with a capacity that can support the weight of the packaging and that complies with safety regulations should be employed for unloading operations.</p> <p>Personnel must be equipped with the necessary personal protection equipment.</p>
--	--

- The manufacturer declines all responsibility regarding the unloading and transport of the machine in the workplace.
- Upon receipt of the machine, verify the packaging is intact. Remove the machine from its packaging and check that it has not been damaged during transport. If damaged components are noted, contact **LARIUS** and the shipping agent in a timely manner. Any damage noted must be communicated within a maximum of 8 days from receipt of the system. The communication must be made via registered mail with return receipt, addressed to **LARIUS** and the shipping agent.

	<p>The disposal of packaging materials, which is the responsibility of the user, must be carried out in compliance with laws in force in the country where the machine is used.</p> <p>However, it is good practice to recycle the packaging materials as much as possible in an environmentally-friendly way.</p>
--	--

## E SAFETY REGULATIONS

- THE EMPLOYER MUST EDUCATE PERSONNEL ABOUT THE RISKS OF INJURIES, OPERATOR SAFETY DEVICES AND THE GENERAL ACCIDENT PREVENTION RULES ESTABLISHED BY INTERNATIONAL DIRECTIVES AND LEGISLATION IN THE COUNTRY WHERE THE MACHINE IS INSTALLED IN ADDITION TO REGULATIONS CONCERNING ENVIRONMENTAL POLLUTION.

- PERSONNEL MUST CAREFULLY OBSERVE ACCIDENT PREVENTION REGULATIONS OF THE COUNTRY WHERE THE MACHINE IS INSTALLED AS WELL AS REGULATIONS CONCERNING ENVIRONMENTAL POLLUTION.

	<p>Carefully read the following instructions in their entirety before using the machine.</p> <p>Keep these instructions in a safe place.</p>
 	<p>The non-authorized tampering with or replacement of one or more parts that make up the machine, the use of accessories, tools and consumable materials that are different from those recommended by the manufacturer may cause accidents and relieves the manufacturer from all civil and penal liabilities.</p>

- KEEP THE WORK AREA IN ORDER. DISORDER IN THE WORKPLACE CAUSES DANGER AND ACCIDENTS.
- ALWAYS KEEP YOUR BALANCE, AVOIDING UNSAFE POSITIONS.
- BEFORE USE THOROUGHLY CHECK THAT THERE ARE NO DAMAGED PARTS AND THAT THE MACHINE IS ABLE TO PROPERLY CARRY OUT ITS FUNCTION.
- ALWAYS OBSERVE SAFETY INSTRUCTIONS AND REGULATIONS IN FORCE.
- DO NOT ALLOW PERSONS NOT INVOLVED IN THE OPERATION OF THE MACHINE TO ACCESS THE WORK AREA.
- NEVER EXCEED THE MAXIMUM OPERATING PRESSURES INDICATED.
- NEVER POINT THE SPRAY GUN TOWARDS YOURSELF OR OTHERS. DIRECT CONTACT WITH THE JET MAY CAUSE SERIOUS INJURY. IN CASE INJURIES ARE CAUSED BY THE SPRAY GUN JET IMMEDIATELY SEEK MEDICAL ATTENTION, SPECIFYING THE TYPE OF PRODUCT ABSORBED BY THE SKIN. NEVER UNDERESTIMATE AN INJURY CAUSED BY FLUID INJECTION.
- ALWAYS DISCONNECT THE POWER SUPPLY AND DISCHARGE THE PRESSURE IN THE CIRCUIT BEFORE PERFORMING ANY TYPE OF INSPECTION OR REPLACEMENT OF COMPONENTS OF THE MACHINE.
- NEVER MODIFY ANY COMPONENT OF THE MACHINE. REGULARLY INSPECT THE COMPONENTS OF THE MACHINE. REPLACE DAMAGED OR WORN PARTS.



- TIGHTEN AND CHECK ALL THE CONNECTION FITTINGS BETWEEN THE PUMP, THE FLEXIBLE TUBE AND THE SPRAY GUN BEFORE USING THIS MACHINE.
- ALWAYS USE THE FLEXIBLE TUBE PROVIDED IN THE STANDARD WORK KIT. THE USE OF ACCESSORIES OR EQUIPMENT DIFFERENT THAN THOSE RECOMMENDED IN THIS MANUAL MAY CAUSE INJURY.
- THE FLUID CONTAINED IN THE FLEXIBLE TUBE MAY BE VERY DANGEROUS. HANDLE THE FLEXIBLE TUBE WITH CARE. DO NOT PULL THE FLEXIBLE TUBE TO MOVE THE MACHINE. NEVER USED A DAMAGED OR REPAIRED FLEXIBLE TUBE.

	<p>If the product flows at high speed through the flexible tube static electricity may be created, manifested with small shocks and sparks. The machine should be electrically grounded. The pump is grounded by the grounding wire of the power cable. The spray gun is grounded via a high pressure flexible tube. All the conductive objects that are near the work area must be grounded.</p>
--	---

- ABSOLUTELY AVOID SPRAYING FLAMMABLE PRODUCTS OR SOLVENTS IN CLOSED ENVIRONMENTS.
- ABSOLUTELY AVOID USING THE MACHINE IN ENVIRONMENTS SATURATED WITH POTENTIALLY EXPLOSIVE GASES

	<p>Always verify the compatibility of the product with the materials that make up the system (<i>pump, spray gun, flexible tube and accessories</i>) with which it may come into contact. Do not use paints or solvents that contain halogenated hydrocarbons (<i>such as methylene chloride</i>). Products in contact with aluminium parts of the machine may cause dangerous chemical reactions with risk of explosion.</p>
--	---

	<p>IF THE PRODUCT TO BE USED IS TOXIC, AVOID INHALATION AND ONLY HANDLE USING PROTECTIVE GLOVES, PROTECTIVE GOOGLES AND APPROPRIATE MASKS.</p>
--	--

	<p>USE APPROPRIATE HEARING PROTECTION EQUIPMENT IF WORKING IN THE IMMEDIATE VICINITY OF THE MACHINE.</p>
--	--

**Electrical safety regulations**

- Ensure the switch is in the "OFF" position before inserting the power cable plug into the electrical outlet.
- Do not transport the machine if it is connected to the power supply network.
- Disconnect the plug from the outlet if the machine is not in use and before performing all maintenance or accessory replacement operations.
- Do not drag the machine or disconnect the plug by pulling on the power cable.
- Keep the cable away from heat, mineral oils and sharp edges.
- If the machine is used outdoors, use a suitable extension cord, that is intended and marked for outdoor use.

	<p>Never tamper with the calibration values of the instruments.</p>
--	---

- To prevent injuries, repairs of electrical parts must only be carried out by qualified personnel.

**PRECAUTIONS DURING WORK**

- Do not smoke, do not cause open flames.
- Only the spray guns and the vehicles required for transporting the powders must be in the booths: all other the electrical devices must be outside the booth.
- Ensure that suction capacity in the spray booth is sufficient and that the powder does not accumulate in any part of the booth.
- Verify that the frames and all the electrical devices are properly grounded.
- Ensure the operator is correctly "grounded". Do not use insulated gloves and plastic shoes. Antistatic shoes are recommended.
- Do not enter the spray booth when the machine is operating. Before entering, ensure the locking system of the entire system is working properly.
- Facial masks and protective suits are recommended, when you need to work in environments filled with powder.
- Keep the area surrounding the booth clean, for at least 5 metres.
- Keep the lighting lamps clean. Wash hands and face before eating or drinking.

**HEALTH AND SAFETY**

**The powders:**

- Can cause irritation to the eyes, hands and respiratory system, after prolonged direct contact.
- Are toxic if inhaled.
- Are not flammable, but they can cause combustion if their concentration in the air exceeds the allowable limit.
- Can form a conductor wire, that can be switched on by "open flames", heat or by electrical sparks.



 **Powder leakage:**  
clean with suction tube. Do not sweep.

**Fire:**  
insulate electrical appliances and use foam.

**Contact with eyes:**  
wash with running water and appropriate medicines.

**Inhalation:**  
go outdoors. Put on clean clothes. In case of respiratory difficulty, seek immediate medical attention.

**Ingestion:**  
provide immediate medical care.

- Distance between the electrode and the piece being processed.  
The safety device of the LARIUS CH 200 electrostatic system, when below 20mm, causes a reduction in charging voltage that is so strong that the particles of sprayed powder are no longer charged. Therefore it would be wrong to get too close to narrow points in order to obtain better penetration.

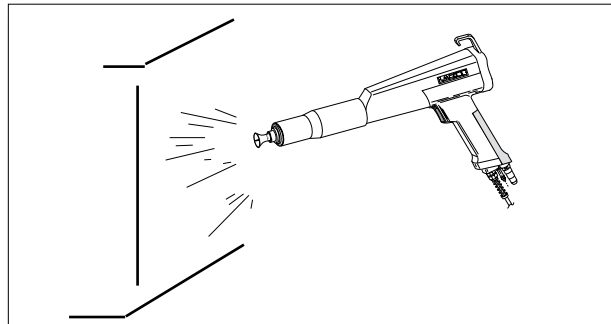

## CONDITIONS OF GUARANTEE

 The conditions of guarantee do not apply in the following situations:

- improper washing and cleaning of components causing malfunction, wear or damage to the equipment or any of its parts;
- improper use of the equipment;
- use that does not conform with applicable national legislation;
- incorrect or faulty installation;
- modifications, interventions and maintenance that have not been authorised by the manufacturer;
- use of non-original spare parts or parts that do not correspond to the specific model;
- total or partial non-compliance with the instructions provided.

- The operator must wear conductive shoes (leather), no gloves, as the operator's ground connection is established through the metal plate on the handle of the spray gun.

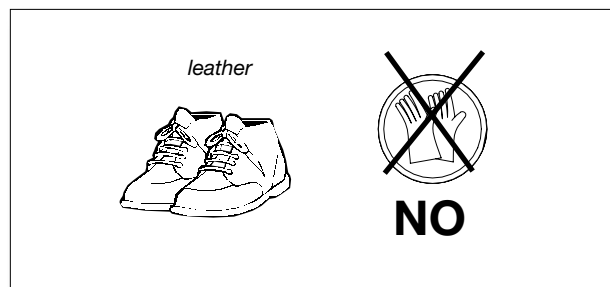

## F CORRECT USE OF THE SYSTEM

The machine described in this manual constitutes a complete and autonomous unit for the application of powder coatings.

Correct use of the machine allows for the full exploitation of the performance that is able to provide in conditions of complete operator safety.

To achieve this, carefully observe the instructions provided below:

- Grounding of all mechanical parts, including the frame of the machine and, of course, the piece being processed.

- The powder tube must not be twisted or bent in any way.

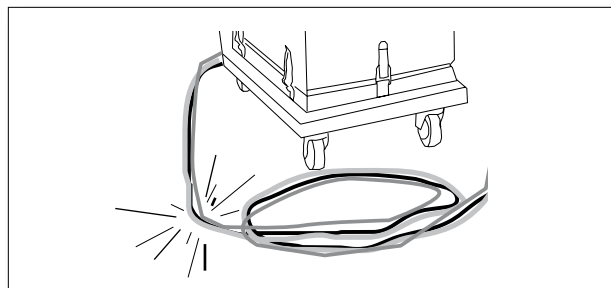





**Follow the instructions included in the use and maintenance manual.**

- Verify the integrity of the components and parts of the machine.
- Observe the instructions and warnings provided on the machine, the safety warning labels on the machine must always be perfectly legible.
- Check the state of preservation (*cleaning*) and maintenance of the machine and its main components.
- Check the correct operation of the pneumatic system and the condition of the pipes and fittings.
- For all operations, always wear suitable clothing, in compliance with workplace safety regulations.
- Report any operating malfunctions (*faulty operation, suspected breakage, incorrect movements and noise that exceeds normal limits*) to the department manager and switch off the machine.
- Observe the maintenance schedule and record, after each check, any observations concerning the maintenance operation performed.
- The powder must be stored in a cool and dry place, in sealed containers that are subject to frequent stock turnover.
- The surfaces of the piece to be treated must be free of any contaminating agents and correctly pretreated.
- The compressed air must not contain water or oil.
- The piece to be treated must be correctly secured and properly grounded.
- The frames must provide good grounding for the piece.
- The temperature of the furnace must be correct in order to polymerise perfectly.
- The powder feeders, the spray booth, and the recovery system must be free of all contaminating agents and free of any powder that is different than that chosen for use.
- Pre-treatment and firing checks must be carried out periodically during processing.
- All the recycled powder must be sieved and mixed with new powder observing the recommended proportions.
- Do not use silicones or paints near the machine.

## **G** INCORRECT USE OF THE SYSTEM

The company LARIUS considers "incorrect use" of the machine to be any use that is not described in the previous paragraph and:

- Do not point the spray gun jet at people.
- Use of improper or inadequate energy sources.  
If modifications must be made to the machine, you must contact **LARIUS** in order to obtain the most up-to-date technology.

- Use of the machine by personnel who is not adequately trained.
- Failure to comply with routine maintenance requirements or maintenance operations performed improperly.
- Use of non-original or unsuitable spare parts.
- Modification or cancellation of safety device settings and/or tampering with the various equipment.
- Perform inspection, maintenance or repair operations without having switched off the machine.
- Make temporary repairs or carry out recovery interventions that do not comply with the instructions.



The company LARIUS is not responsible for mechanical damage to persons caused by incorrect uses as described above.

In the event the customer must use the machine with materials different than those cited in the sales contract or modify the operating parameters, the customer must contact LARIUS for new operating parameters and technologies.

It is recommended that the operator in charge of the machine's operation and the person responsible for its maintenance, keep the safety and control areas and the access area to the parts of the hoist, free of all obstacles and equipment.

## **H** CONTROL PANEL

The operation, adjustment, and stoppage of the system, as well as the instructions concerning correct operation, are managed by the control panel positioned above.



**Install a disconnecting switch with fuses upstream of the main switch, in order to completely isolate the machine from the power supply network.**

### OPERATING CONTROLS

**Buttons - Switches - Indicator lights - Potentiometers**

The operating controls are located on the control panel and are used directly by the operator during operation and to carry out every maintenance or testing operation.

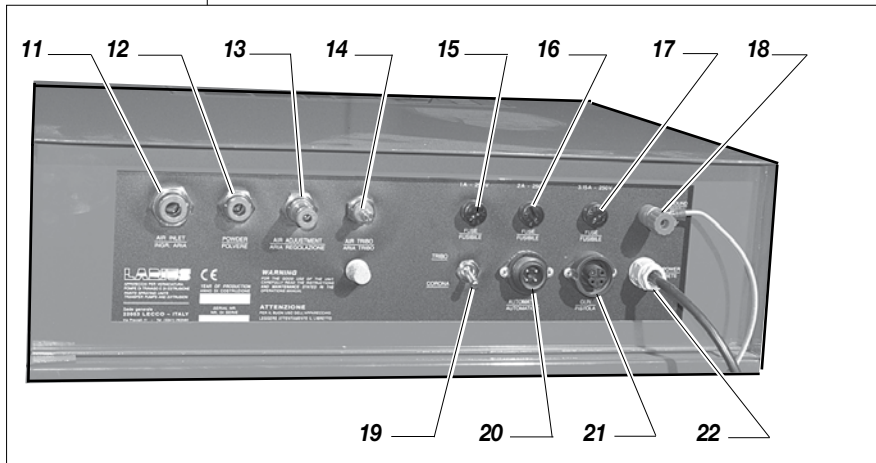
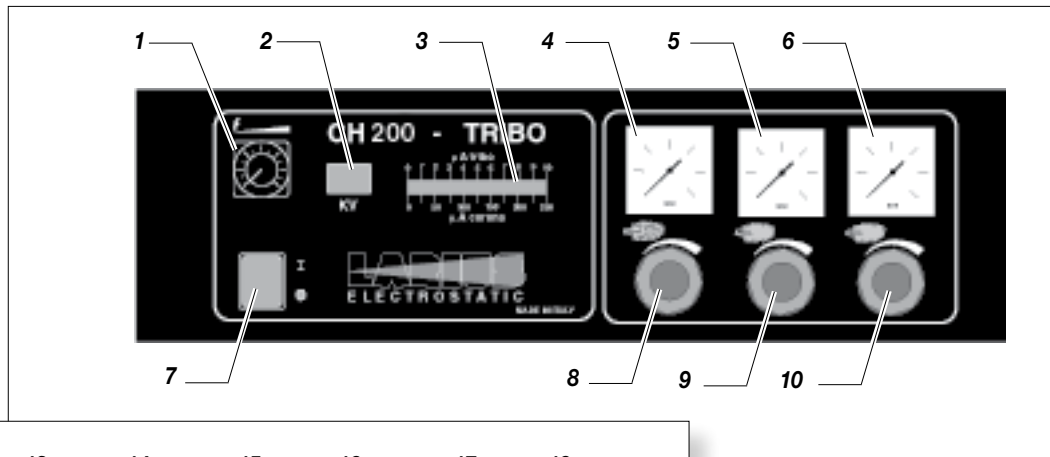

Pos.	Description
1	Kv adjusting potentiometer
2	Kv Digital indicator
3	Led indicator $\mu$ A
4	Pressure gauge for reading powder delivery air pressure
5	Pressure gauge for press. additional air reading
6	Pressure gauge for reading "tribo air" pressure and additional air pressure for cleaning CH 200
7	Main switch
8	Knob for adjusting powder delivery air pressure
9	Additional air pressure adjustment knob (to evenly distribute the jet of powder)
10	Knob for adjusting the "tribo air" (increases the electric effect) pressure and additional air for cleaning the CH200 diffuser and rheophore

Pos.	Description
11	Air inlet tube fixing attachment
12	Powder delivery air tube fixing connection
13	Fixing connection for additional air tube
14	Fixing connection for "tribo air" tube and additional air tube for cleaning CH200
15	Main fuse (1A)
16	Solenoid fuse (2A)
17	Main PCB fuse (3.15 A)
18	Grounding cable fixing coupling
19	Selector for corona or electric painting
20	Outlet for automatic spray gun control cable
21	Outlet for spray gun supply cable
22	Power cable



## CURRENT OUTPUT ADJUSTMENT $\mu$ A

The electronic processing board located inside the generator is supplied complete with a current limiter device that allows, if necessary, increasing the current without modifying the set voltage.

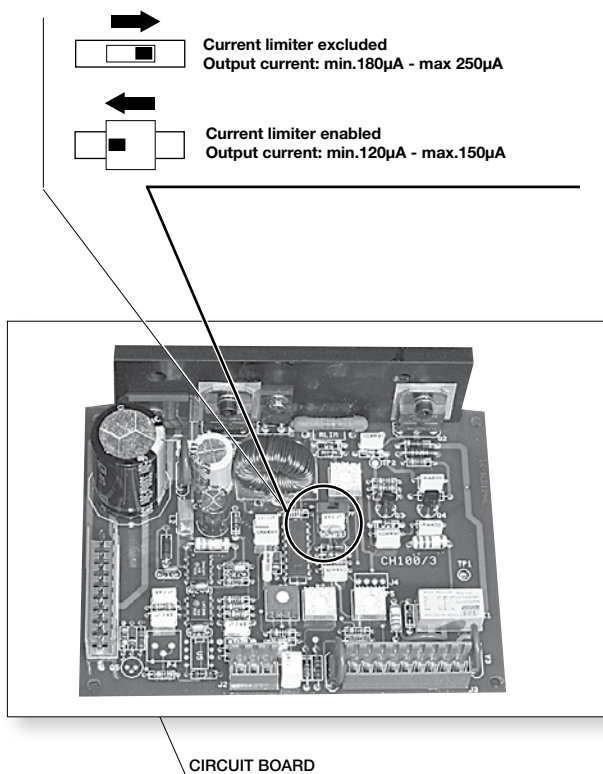
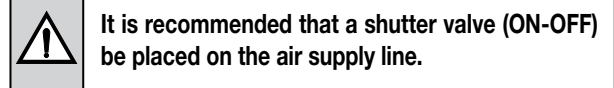
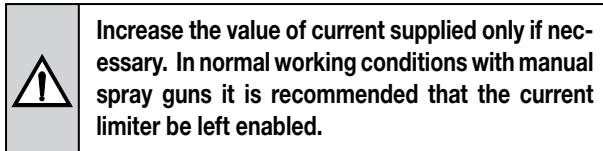

- Connect the machine to the compressed air supply using a suitable type tube (H2), it must have a internal diameter that is not less than 8 mm and must be able to withstand a maximum pressure of 10 bar.  
The tube must be connected to the (H3) filter.

The humidity of the air must be less than 1 gr. of water p.p.m. The quantity of air required depends on the operating pressure (200-600 L/min.).  
The compressor that supplies the air must be grounded separately with its own grounding cable.

- Connect the compressed air supply tube (H4)  $\varnothing$  10 mm to the rear of the rack's control panel.
- Connect the powder supply tube (H6) and the additional air tube (H7) to the powder supply pump and to the generator (H5).
- Connect the generator to the spray booth using a grounding cable (H8) and clamp (H9).
- Connect the vent tube (H10) to the tank cover and the spray booth (or to a container).

### Electrostatic spray gun

- Connect the power supply cable (H11) to the spray gun and the generator.
- Connect the powder passage tube (H12) to the spray gun and the powder delivery pump.
- Connect the additional air passage tube (H13) for cleaning the diffuser and rheophore to the spray gun and the generator.

## CONNECTIONS

- Make sure the system is equipped with a grounding connection
- Ensure that the mains voltage corresponds to that indicated on the machine's nameplate.
- Make sure the switch is in the "0" position.
- Connect the machine to the mains using the dedicated cable (H1).

### Triboelectric spray gun

- If spray guns are used which employ the triboelectric paint system, remove the tribo air outlet cap and connect the tube (H14) to the tribo spray gun.

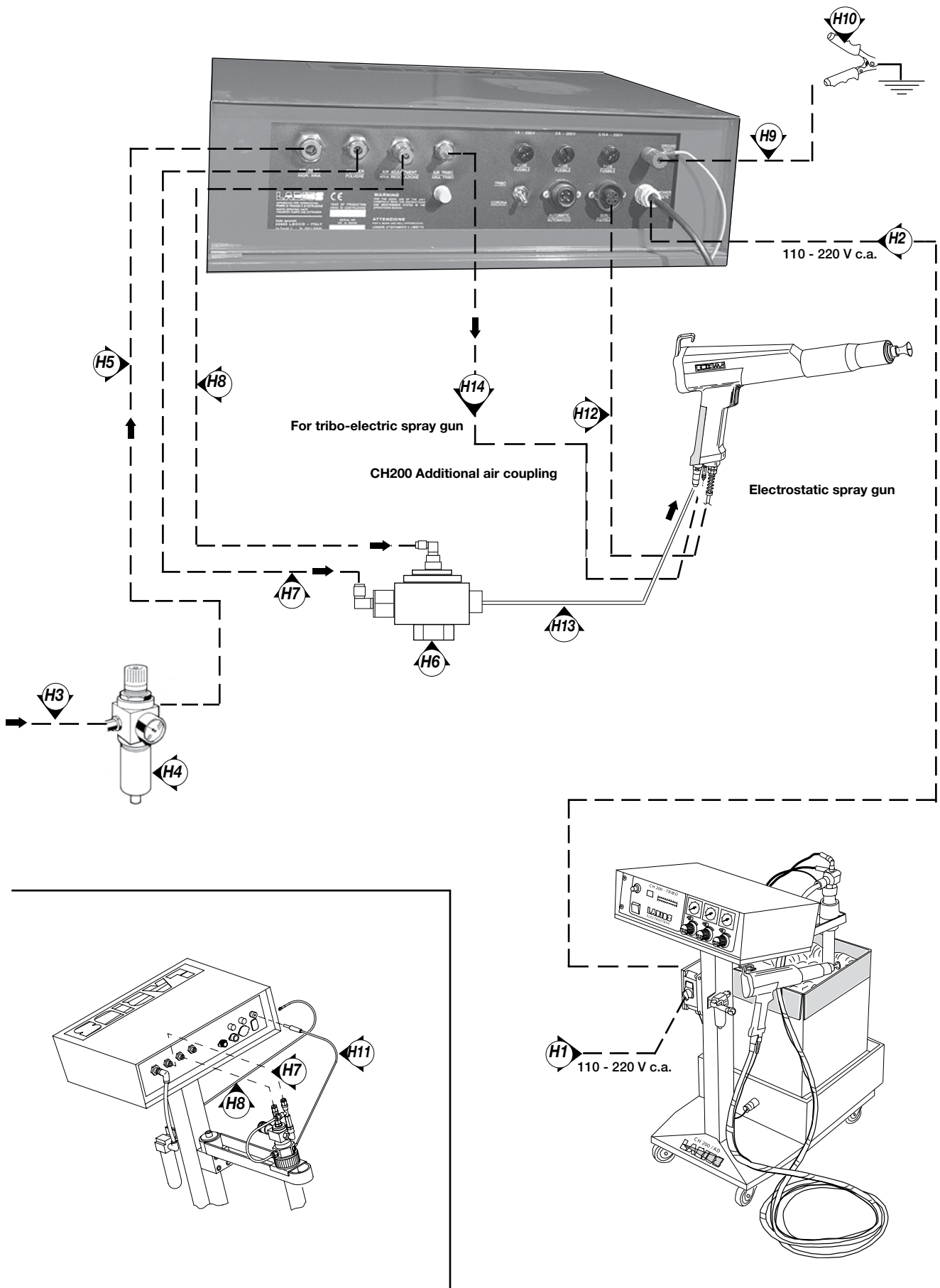



**OPERATION**

After having carried out all the electrical and pneumatic connections as described in the previous chapter, proceed as follows:

- Turn the revolving arm (H15) in order to be able to position the cardboard box (H16) containing the powder on the vibrating surface (H17) as illustrated in the figure.
- Lift up the powder suction tube (H18). Loosening the locking ring nut (H19), it is possible to slide the suction tube along the revolving arm.
- Turn the revolving arm (H15) and position it above the powder container.
- Lower the powder suction tube (H18) inside the container.
- Open the air supply to the machine.
- Press the main switch (H20) of the control panel to power the generator.
- Turn the switch (H21) of the electric vibrator to the "ON" position.

 **The electric vibrator is activated each time the spray gun trigger is pressed and it automatically stops every time the trigger is released.**

**USE WITH CH 200 SPRAY GUN (corona effect)**

 **To use with the CH 200 spray gun (corona effect), make sure the selector (H17) is in the "CORONA" position.**



H22

- Point the spray gun inside the spray booth and hold down the trigger to adjust the powder delivery setting.
- Adjust the air pressure delivered to the powder supply pump (H18), using the regulator (H19) and reading the value expressed in bar on the pressure gauge H20 (max recommended values 3-4 bar).

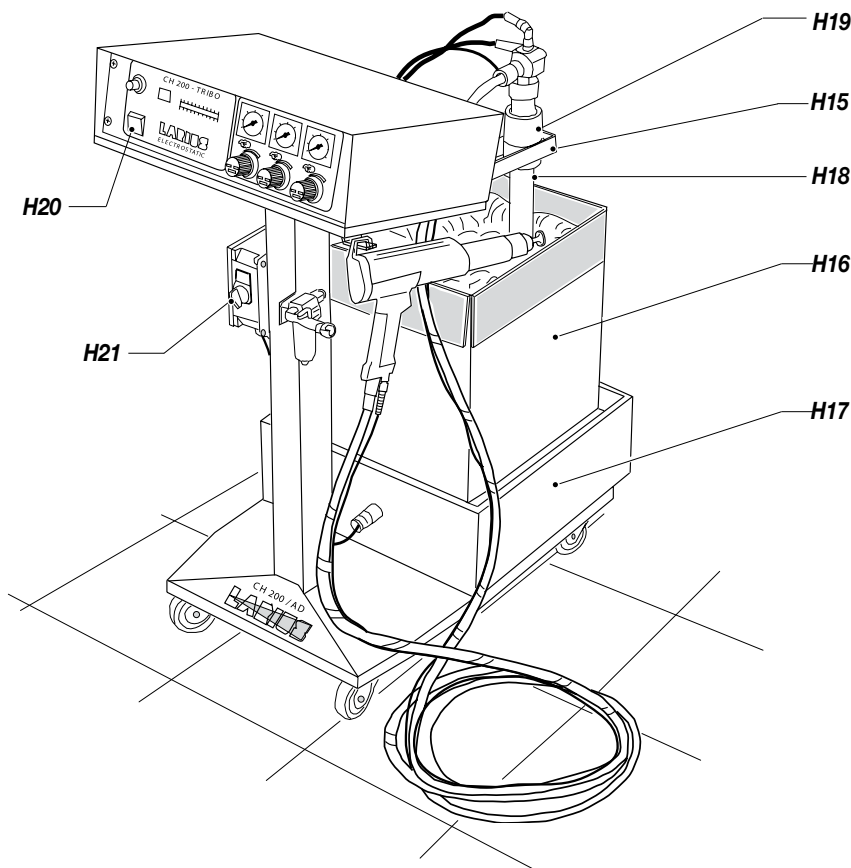

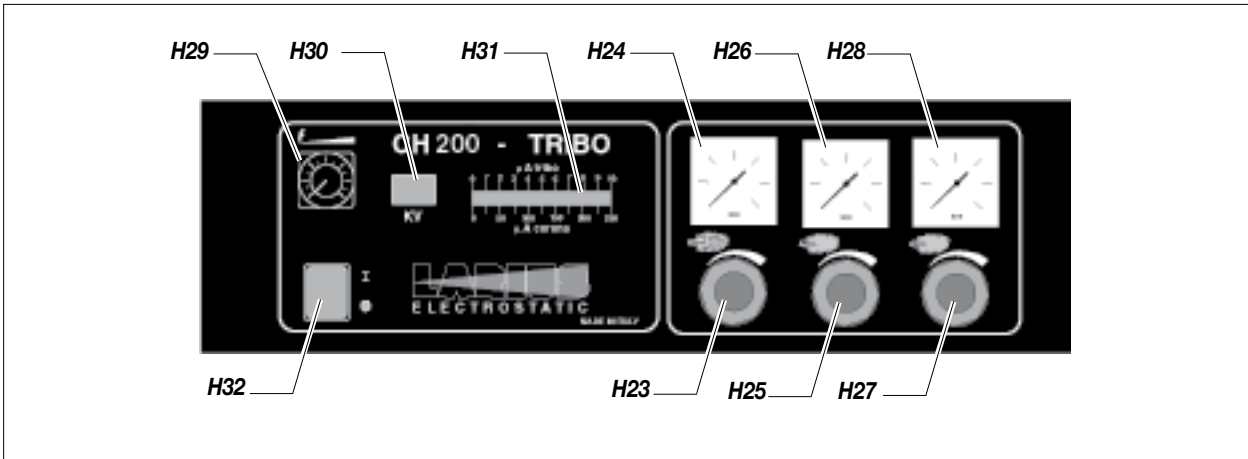

- Adjust the powder diffusion range of the spray gun using the knob (H21) and reading the value expressed in bar on the pressure gauge (H22), (recommended values 0.5-2 bar); however, this value must always be less than the supply air pressure (pressure gauge H23); once adjustment is complete, release the spray gun trigger.
- Adjust the flow of the additional air that controls the cleaning of the diffuser and charging rheophore. Using the knob (H24) and checking the pressure gauge (H25) set the outlet air pressure to the recommended values between 0.5-1 bar. Depending on the amount of powder delivered, ensure the cleaning cone cleans the powder residue from the affected areas.
- Using the potentiometer (H26) select the desired voltage value (0 -100 kv) read the set value on the digital display (H27).
- Point the spray gun at the object to be painted (recommended distance 15-20 cm) and press the trigger, which will start to deliver powder, as well as high voltage; the value of current, expressed in microamperes (max 250  $\mu$ A) can be read on the lit indicator (H3).

 **Protect the spray gun from all violent mechanical action. Repeated impacts and shocks of considerable intensity, while not altering the outer integrity of the spray gun, may cause internal damage and cause the spray gun to become unusable.**

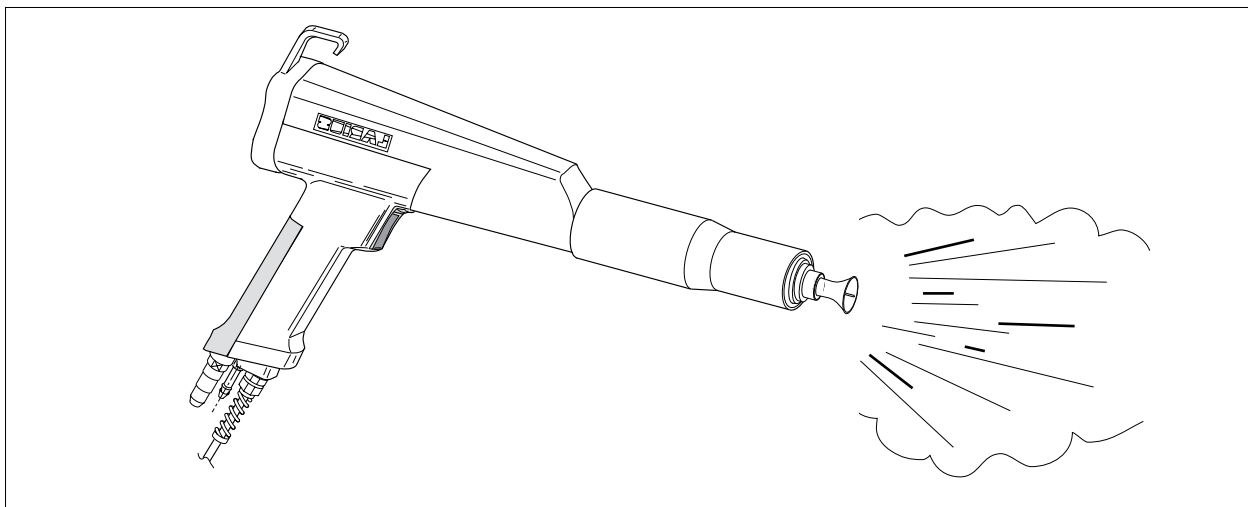



## USE WITH THE TRIBOELECTRIC SPRAY GUN

 To use with the triboelectric spray gun, make sure the selector (H22) is in the "TRIBO" position.

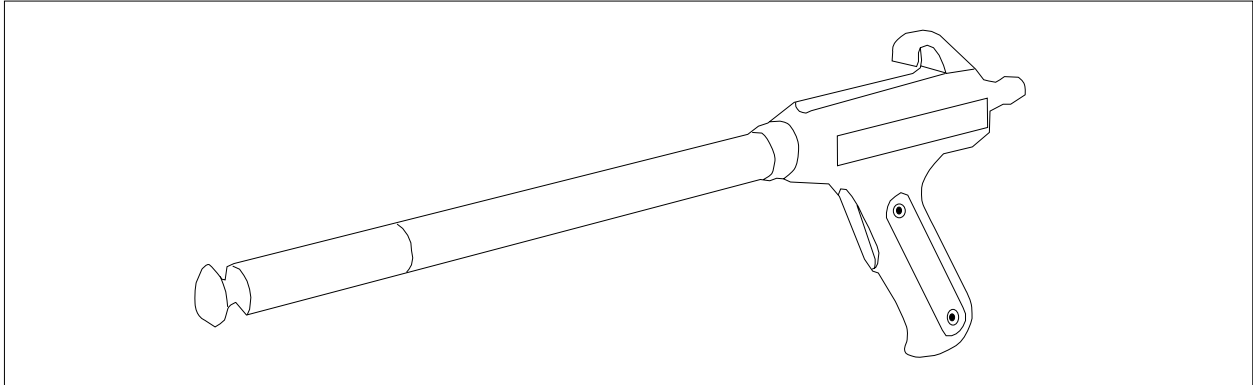

- Point the spray gun at the object to be painted (recommended distance 15-20 cm) and press the trigger, which will start to deliver powder, as well as high voltage; the value of current, expressed in microamperes (max 250  $\mu$ A) can be read on the lit indicator (H28).
- Adjust the air pressure to the powder supply pump (H29), by turning the regulator (H30) and reading the value expressed in bar displayed on the pressure gauge (H23) (recommended max values 3-4 bar).
- Adjust the powder diffusion range of the spray gun using the knob (H29) and reading the value expressed in bar on the pressure gauge (H22), (recommended values 0.5-2 bar); however, this value must always be less than the supply air pressure (pressure gauge H23).
- Adjust the "tribo air" pressure using the knob (H24) and reading the pressure value set on the pressure gauge (H25).

If the pressure is increased, the triboelectric effect is also increased.

The electrostatic charge value can be read on the luminous indicator (H28) located on the generator.  
At this point, release the spray gun trigger.

Point the spray gun at the object to be painted (recommended distance 10-20 cm) and press the spray gun trigger, which will start to deliver powder.

The value of the current expressed in  $\mu$ A (max 10  $\mu$ A) can be read on the luminous indicator (H28).

 **Protect the spray gun from all violent mechanical action. Repeated impacts and shocks of considerable intensity, while not altering the outer integrity of the spray gun, may cause internal damage and cause the spray gun to become unusable.**



# I CYCLICAL ROUTINE MAINTENANCE

 Before performing any maintenance or cleaning operation disconnect the electric and pneumatic power supply.

## EVERY 8 HOURS AND/OR AT EVERY COLOUR CHANGE

### Cleaning the CH200 spray gun

- Disconnect the powder supply tube and remove the nozzle (I1) of the spray gun.
- Clean the inner part of the spray gun and nozzle with a jet of compressed air. If necessary, use the brush supplied to clean the spray gun.

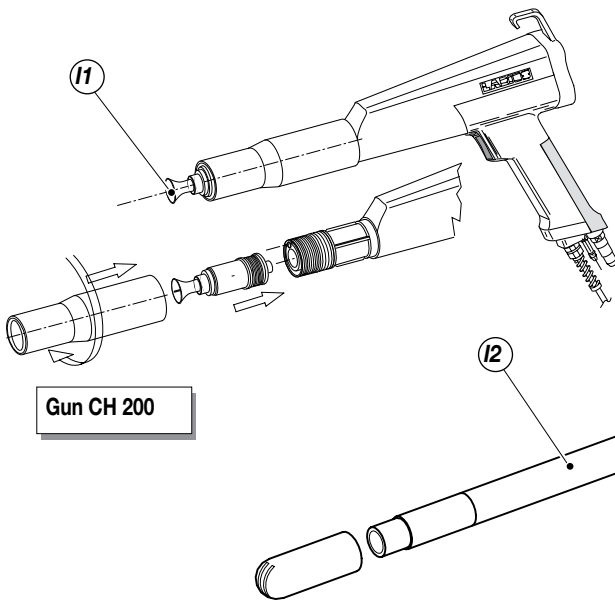

### Cleaning the triboelectric spray gun

- Disconnect the powder supply tube and remove the nozzle. Clean the inner part of the spray gun and nozzle with a jet of compressed air.
- If removing the triboelectric spray gun is necessary

Using your hands, unscrew the charge tube (I2) from the spray gun body. Using your hands, slip off the diffuser (I3). Remove the nozzle.

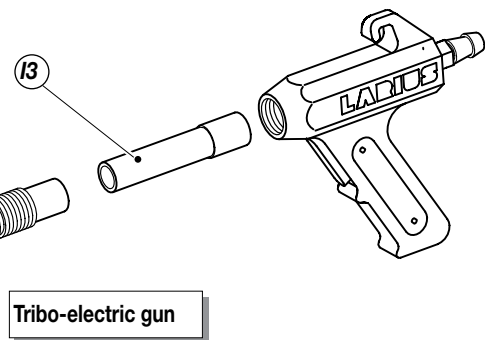

## EVERY 40 - 80 HOURS AND/OR AT EVERY COLOUR CHANGE

### Cleaning the powder supply tube

- Disconnect the powder supply tube (I4) from the tank and spray gun and blow in compressed air to remove any remaining powder residue. Ensure the powder passage tube is not cracked, bent or damaged in any way.

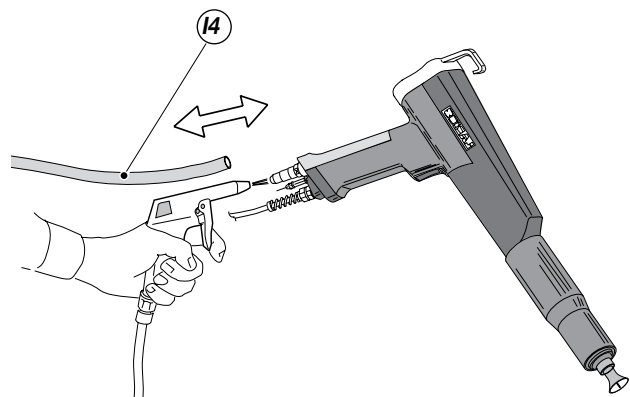



**EVERY 40 - 80 HOURS**

**Check venturi diffuser**

- Check the wear of the powder delivery pump's Venturi diffuser (15).  
A new diffuser hole is 4.8mm; with wear the hole's diameter

increases, decreasing the Venturi effect and, when the hole reaches 8 mm, the diffuser must be replaced.  
For highly abrasive materials use tungsten carbide diffusers.

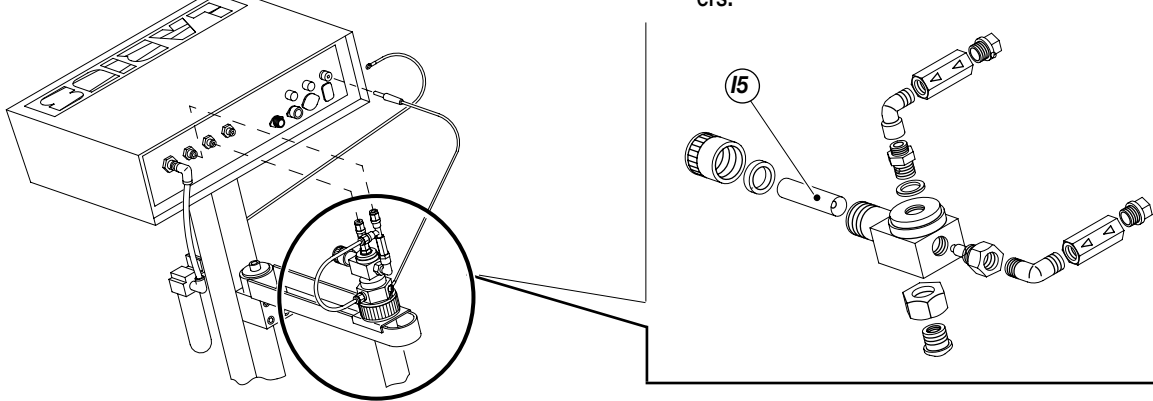

**EVERY 40 - 80 HOURS**

**Cleaning the pressure reducer filter**

To ensure proper machine operation, follow these rules:

- Ensure proper operation of the pressure reducer filter. Ensure there is no condensation build-up inside the cup. If necessary, periodically discharge the condensation by unscrewing the bleed screw (16) under the filter cup; the pressure inside the cup will cause the expulsion of the condensation.
- Periodically clean the filter cartridge in order to prevent system performance losses.  
Wash the cup with water and dry with a jet of compressed air.

 Before removing the cup close the compressed air supply.

**Adjusting the pressure**

Adjust the pressure by turning the knob located on the upper part of the reducer.

To increase it turn clockwise (+).

To decrease it turn counter clockwise (-).

Do not power the pneumatic system with compressed air that is excessively dirty or that contains aggressive liquids.

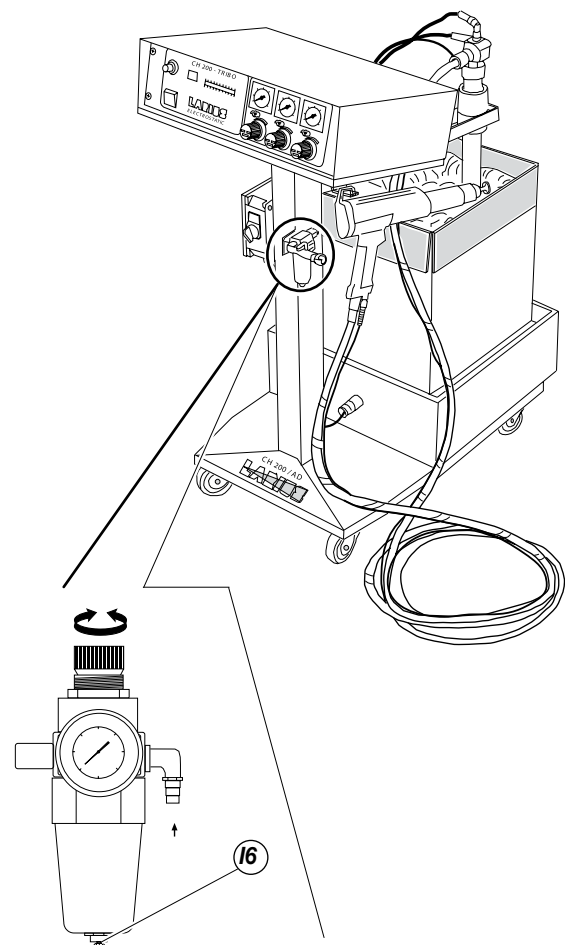



## J COLOUR CHANGING

The design of the CH 200/AD unit allows for quick colour changing, directly using the original box containing the powder. To change the colour, proceed as follows:

- Disconnect the electric and pneumatic mains supply that powers the machine.
- Turn the revolving arm (J1) in order to remove the cardboard box (J2).
- Lift up the powder suction tube (J3). Loosening the locking ring nut (J4) it is possible to slide the suction tube along the revolving arm.
- Remove the box and replace it with that of the new colour which you intend to use, correctly placing it on the shaking table (J5).
- Turn the revolving arm (J1) and position it above the powder container.
- Lower the (J3) powder suction tube inside the container.
- Open the air supply to the machine.
- Press the main switch (J6) of the control panel to power the generator.
- Turn the switch (J7) of the electric vibrator to the "ON" position.

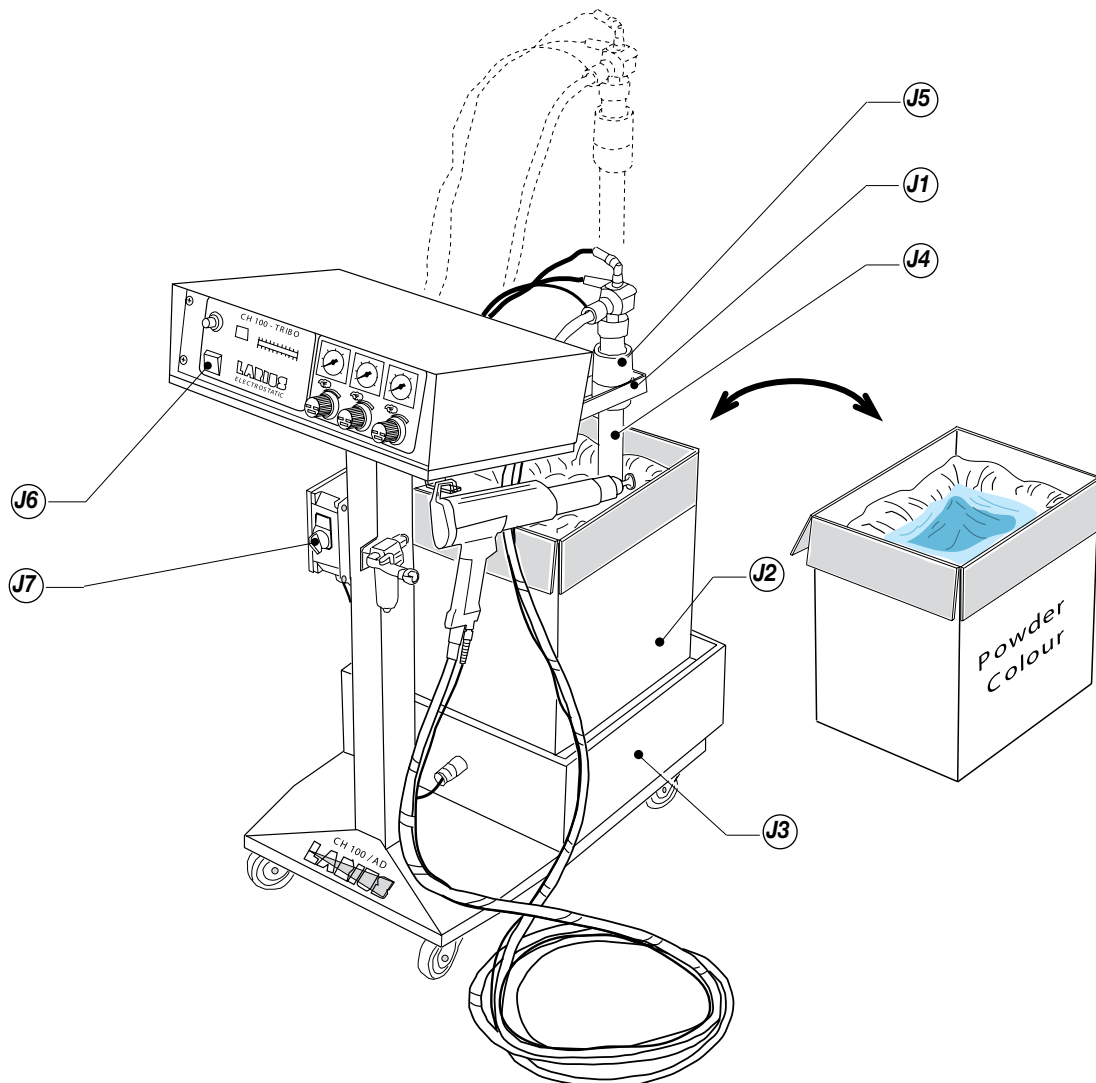



## K PROBLEMS AND SOLUTIONS

Problem	Cause	Solution
<ul style="list-style-type: none"> <li>Electrical charges between the spray gun nozzle and the object to be painted</li> </ul>	<ul style="list-style-type: none"> <li>Excessive voltage;</li> <li>For CH 200 spray gun: excessive electric current;</li> <li>For CH 200 spray gun: nozzle damaged;</li> <li>The object to be painted is not properly electrically grounded;</li> <li>For CH 200 spray gun the voltage multiplier is defective;</li> </ul>	<ul style="list-style-type: none"> <li>For CH 200 spray gun: decrease the voltage using the rack's potentiometer;</li> <li>For spray gun: decrease the air pressure;</li> <li>Reset the current limiter switch located on the processing board ;</li> <li>Replace the nozzle;</li> <li>With a tester or similar instrument check the electrical grounding of the piece holder hooks. If necessary, clean the piece holder hooks;</li> <li>Replace the voltage multiplier;</li> </ul>
<ul style="list-style-type: none"> <li>The machine does not start up after the ON-OFF switch has been pressed</li> </ul>	<ul style="list-style-type: none"> <li>No mains voltage;</li> <li>Fuse 1A is defective;</li> </ul>	<ul style="list-style-type: none"> <li>Check the electric supply line;</li> <li>Replace the 1A fuse;</li> </ul>
<ul style="list-style-type: none"> <li>The rack switches on but the Kv display is not working</li> </ul>	<ul style="list-style-type: none"> <li>Fuse 3.15A is defective;</li> <li>Processing board defective;</li> </ul>	<ul style="list-style-type: none"> <li>Replace the 3.15A fuse;</li> <li>Replace the processing board;</li> </ul>
<ul style="list-style-type: none"> <li>The kv display lights up but the kv scale does not increase when the potentiometer is turned</li> </ul>	<ul style="list-style-type: none"> <li>KV control potentiometer defective, processing board defective or display board defective</li> </ul>	<ul style="list-style-type: none"> <li>Proceed as follows:                             <ul style="list-style-type: none"> <li>Disconnect the power supply</li> <li>Remove the four fixing screws and slip the rack off the CH 200-tribo machine's protective cover.</li> <li>Remove the connector marked j3 from the processing board.</li> <li>Using a tester (or similar instrument capable of measuring electrical resistance) check the integrity of the potentiometer: connect a tip of the tester to the central terminal of the potentiometer and the other tip to one of the two side terminals. Turning the potentiometer knob, the resistance value read on the tester varies from 0 to 1 K<math>\Omega</math>, approximately.</li> <li>If a negative result is obtained, replace the potentiometer.</li> </ul> </li> </ul>
<ul style="list-style-type: none"> <li>The machine is working but the powder does not come out of the spray gun when the trigger is pressed.</li> </ul>	<ul style="list-style-type: none"> <li>No powder;</li> <li>Powder delivery pump clogged;</li> <li>The air pressure is not sufficient to adjust powder delivery;</li> <li>Fuse 2 A is defective;</li> <li>Spray gun-generator cable incorrectly connected or damaged;</li> </ul>	<ul style="list-style-type: none"> <li>Add powder;</li> <li>Remove the powder delivery pump and clean the passages;</li> <li>Increase the air pressure to adjust powder delivery;</li> <li>Replace the 2 A fuse;</li> <li>Check the connections; verify the continuity of the cable connections using a tester and, if necessary, replace it;</li> </ul>



Problem	Cause	Solution
<ul style="list-style-type: none"> <li>Rapid wear of Venturi diffuser</li> </ul>	<ul style="list-style-type: none"> <li>No mains voltage;</li> </ul>	<ul style="list-style-type: none"> <li>Use a hard metal Venturi diffuser (code 5296/A);</li> </ul>
<ul style="list-style-type: none"> <li>The powder puffs out of the spray gun</li> </ul>	<ul style="list-style-type: none"> <li>Worn or partially clogged Venturi;</li> <li>The additional air pressure is excessive (rack central regulator) or the ratio between this and the powder delivery air pressure is incorrect (left rack regulator);</li> <li>The tank's fluid bed air pressure is excessive or insufficient;</li> <li>The unidirectional valves of the powder pump are partially clogged;</li> <li>Powder passage tube too short or with excessive inner diameter;</li> </ul>	<ul style="list-style-type: none"> <li>Clean and/or replace the Venturi;</li> <li>Decrease the additional air pressure and/or increase the powder delivery air pressure. <b>Important:</b> The additional air pressure must always be lower than the powder delivery air pressure;</li> <li>Adjust the fluid bed air pressure (recommended pressure value: 0.5-1bar);</li> <li>Clean and/or replace the unidirectional valves;</li> <li>Use the powder passage tube supplied or a tube with an inner diameter that is no greater than 12mm and with a length no less than 5 metres;</li> </ul>
<ul style="list-style-type: none"> <li>Insufficient powder flow</li> </ul>	<ul style="list-style-type: none"> <li>The air pressure for adjusting the powder delivery is insufficient;</li> <li>The powder is too wet and is sucked up by the powder pump with difficulty;</li> <li>Worn or partially clogged Venturi;</li> </ul>	<ul style="list-style-type: none"> <li>Increase the air pressure to adjust powder delivery;</li> <li>Check the compressed air supply line. Install an air dryer if necessary;</li> <li>Clean and/or replace the Venturi;</li> </ul>
<ul style="list-style-type: none"> <li>The powder is not sufficiently electrostatically charged and/or does not "cover"</li> </ul>	<ul style="list-style-type: none"> <li>The additional air pressure (central regulator rack) is excessive;</li> <li>The additional nozzle cleaning air pressure is excessive;</li> <li>The piece to be painted is not properly electrically grounded;</li> <li>The powder is not suited for use with a corona and/or triboelectric system;</li> <li>Only for triboelectric spray gun: The "tribo" air pressure (central regulator rack) is excessive;</li> <li>For CH 200 spray gun: nozzle damaged and/or dirty;</li> </ul>	<ul style="list-style-type: none"> <li>Decrease the additional air pressure;</li> <li>Decrease the additional air pressure;</li> <li>With a tester or similar instrument check the electrical grounding of the piece holder hooks. If necessary, clean the piece holder hooks;</li> <li>Consult the powder supplier;</li> <li>Increase the "tribo" air pressure to increase the triboelectric effect;</li> <li>Clean and/or replace the nozzle;</li> </ul>
<ul style="list-style-type: none"> <li>The powder "cover" but the <math>\mu\text{A}</math> scale does not increase</li> </ul>	<ul style="list-style-type: none"> <li>For triboelectric spray gun: charge tube dirty and/or damaged;</li> <li>Display board not working;</li> <li>For triboelectric spray gun: tribo-corona switch set to "corona";</li> </ul>	<ul style="list-style-type: none"> <li>Clean and/or replace the charge tube;</li> <li>Replace the display board;</li> <li>Move the switch to "tribo";</li> </ul>



Problem	Cause	Solution
	<ul style="list-style-type: none"> <li>• For triboelectric spray gun: spray gun-generator cable not connected properly or damaged;</li> <li>• For triboelectric spray gun: processing board damaged.</li> </ul>	<ul style="list-style-type: none"> <li>• Check the connections; verify the continuity of the cable connections using a tester and, if necessary, replace it;</li> <li>• Replace the processing board;</li> </ul>
<ul style="list-style-type: none"> <li>• <b>The powder does not charge and does not "cover"</b></li> </ul>	<ul style="list-style-type: none"> <li>• The powder is not suited for use with a corona and/or triboelectric system;</li> <li>• For CH 200 spray gun: processing board damaged ;</li> <li>• For CH 200 spray gun: tribo-corona switch on "tribo";</li> <li>• For CH 200 spray gun: nozzle electrodes are broken or nozzle is not secured correctly to the spray gun;</li> <li>• For CH 200 spray gun: the voltage multiplier is defective;</li> </ul>	<ul style="list-style-type: none"> <li>• Consult the powder supplier;</li> <li>• Replace the processing board;</li> <li>• Move the switch to "corona";</li> <li>• Correctly secure the nozzle and/or replace the nozzle;</li> <li>• Replace the voltage multiplier;</li> </ul>
<ul style="list-style-type: none"> <li>• <b>The machine is working but the powder does not come out of the spray gun when the trigger is pressed.</b></li> </ul>	<ul style="list-style-type: none"> <li>• Solenoid valve or processing board not working;</li> <li>• Spray gun button defective</li> </ul>	<ul style="list-style-type: none"> <li>• Replace the solenoid and/or processing board;</li> <li>• For triboelectric spray gun:               <ul style="list-style-type: none"> <li>- Disconnect the spray gun-generator connecting cable from the generator;</li> <li>- With a tester (or similar instrument capable of measuring electrical resistance) verify the electrical continuity between the terminals marked with a 1 and the connector when the spray gun trigger is pressed;</li> <li>- If the result of the test is negative, proceed with replacing, in order, the trigger lever, then the trigger body, and lastly both parts;</li> </ul> </li> <li>• For CH 200 spray gun:               <ul style="list-style-type: none"> <li>- Disconnect the spray gun-generator connecting cable from the generator;</li> <li>- With a tester (or similar instrument capable of measuring electrical resistance) verify the electrical continuity between the terminals marked with a 1 and the connector when the spray gun trigger is pressed;</li> <li>- If the result of the test is negative, proceed with replacing, in order, the trigger, then the reed block, and lastly both parts;</li> </ul> </li> </ul>



Problem	Cause	Solution
<ul style="list-style-type: none"> <li>The machine is working and the powder comes out of the spray without the trigger.</li> </ul>	<ul style="list-style-type: none"> <li>Spray gun button defective</li> </ul>	<ul style="list-style-type: none"> <li>Replace the solenoid and/or processing board;</li> <li>For triboelectric spray gun:               <ul style="list-style-type: none"> <li>Disconnect the spray gun-generator connecting cable from the generator;</li> <li>With a tester (or similar instrument capable of measuring electrical resistance) verify the electrical continuity between the terminals marked with a 1 and the connector when the spray gun trigger is pressed;</li> <li>If the result of the test is negative, proceed with replacing, in order, the trigger lever, then the trigger body, and lastly both parts;</li> </ul> </li> <li>For CH 200 spray gun:               <ul style="list-style-type: none"> <li>Disconnect the spray gun-generator connecting cable from the generator;</li> <li>With a tester (or similar instrument capable of measuring electrical resistance) verify the electrical continuity between the terminals marked with a 1 and the connector when the spray gun trigger is pressed;</li> <li>If the result of the test is negative, proceed with replacing, in order, the trigger, then the reed block, and lastly both parts;</li> </ul> </li> </ul>
<ul style="list-style-type: none"> <li>The machine is working but the electro-vibrator fails to switch on when the spray gun trigger is pressed.</li> </ul>	<ul style="list-style-type: none"> <li>Vibrator switch in the "OFF" position;</li> <li>Electro-vibrator defective.</li> </ul>	<ul style="list-style-type: none"> <li>Turn the switch to the "ON" position;</li> <li>Replace the electro-vibrator.</li> </ul>



Always disconnect the power supply and discharge the pressure before performing any checks or replacing parts of the pump (follow the "correct pressure relief procedure").



# SPARE PARTS

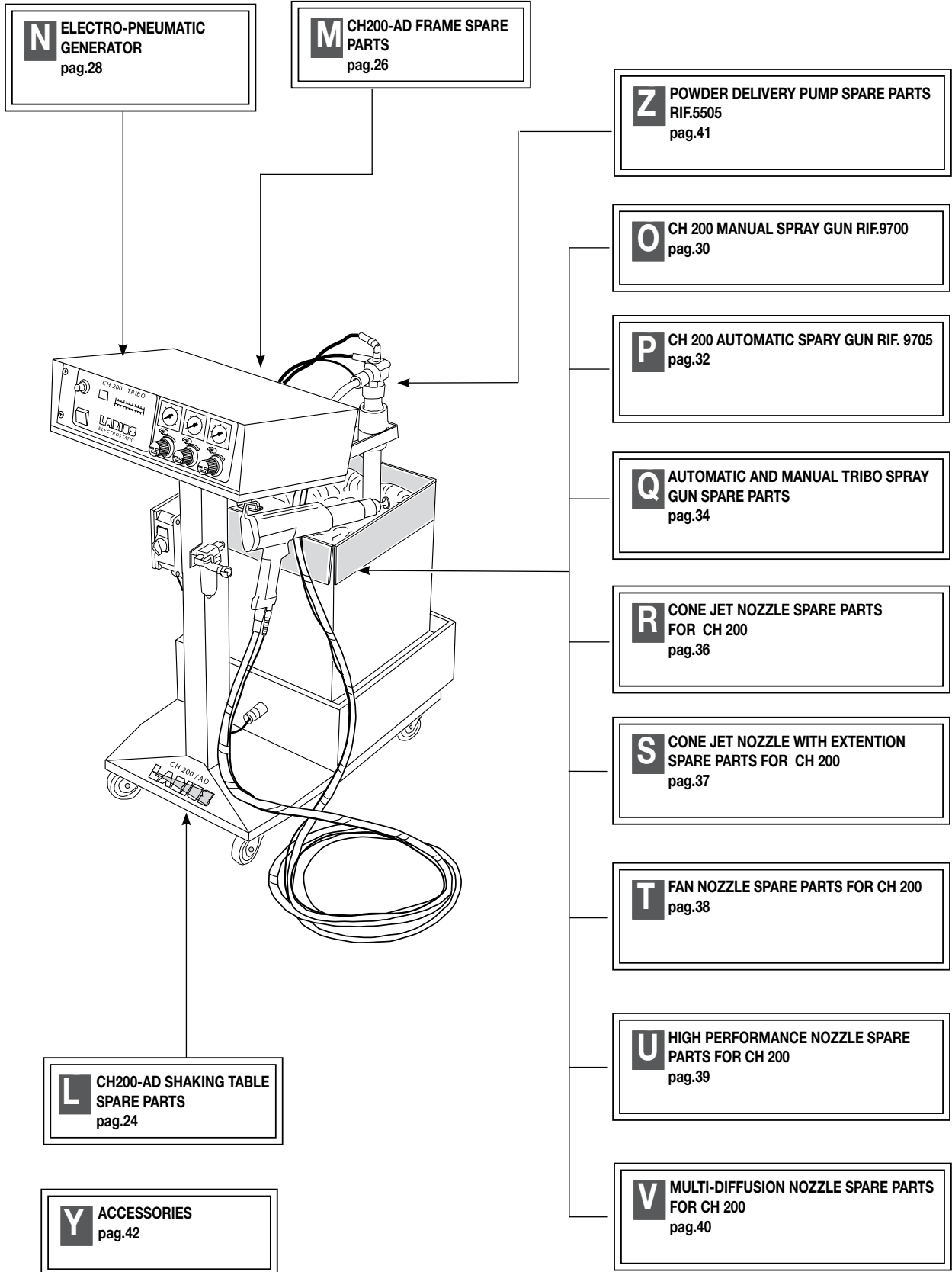



# CH 200-AD SHAKING TABLE SPARE PARTS

**WARNING:** Always indicate code and quantity for each part required.

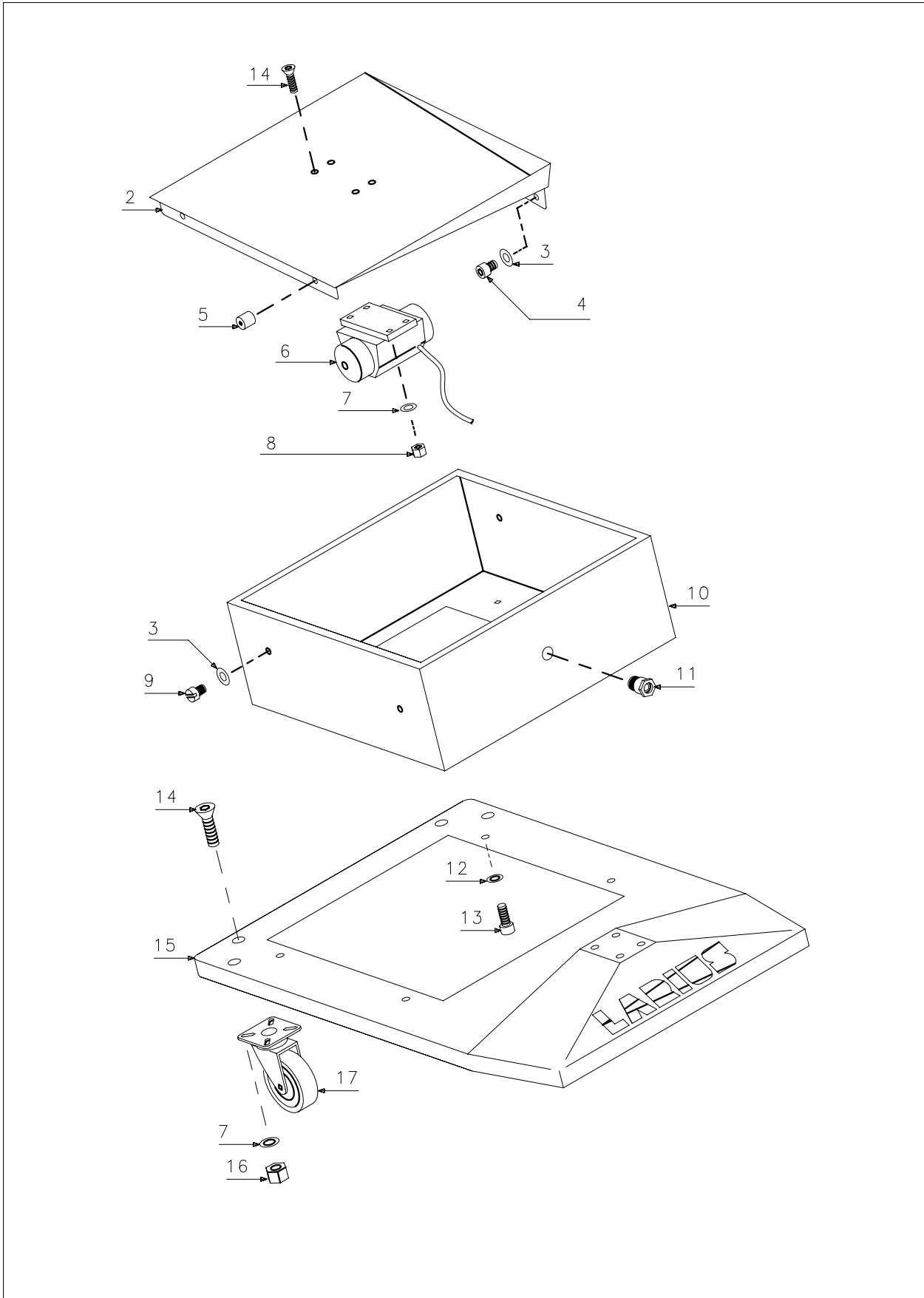



Pos.	Code	Description	Pos.	Code	Description
1	510425	Screw	9	5727	Screw
2	5877	Shaking table	10	5878	Shaking table base
3	5725	Washer	11	5729	cable gland
4	5726	Screw	12	54003	Washer
5	5728	Vibration damper	13	54004	Screw
6	5723	Vibrator 220 V	14	5583	Screw
6	5757	Vibrator 110 V	15	5738	Trolley base
7	95063	Washer	16	91026	Nut
8	8042	Self-locking nut	17	5582	Wheel



# M FRAME SPARE PARTS CH 200-AD

**WARNING:** Always indicate code and quantity for each part required.

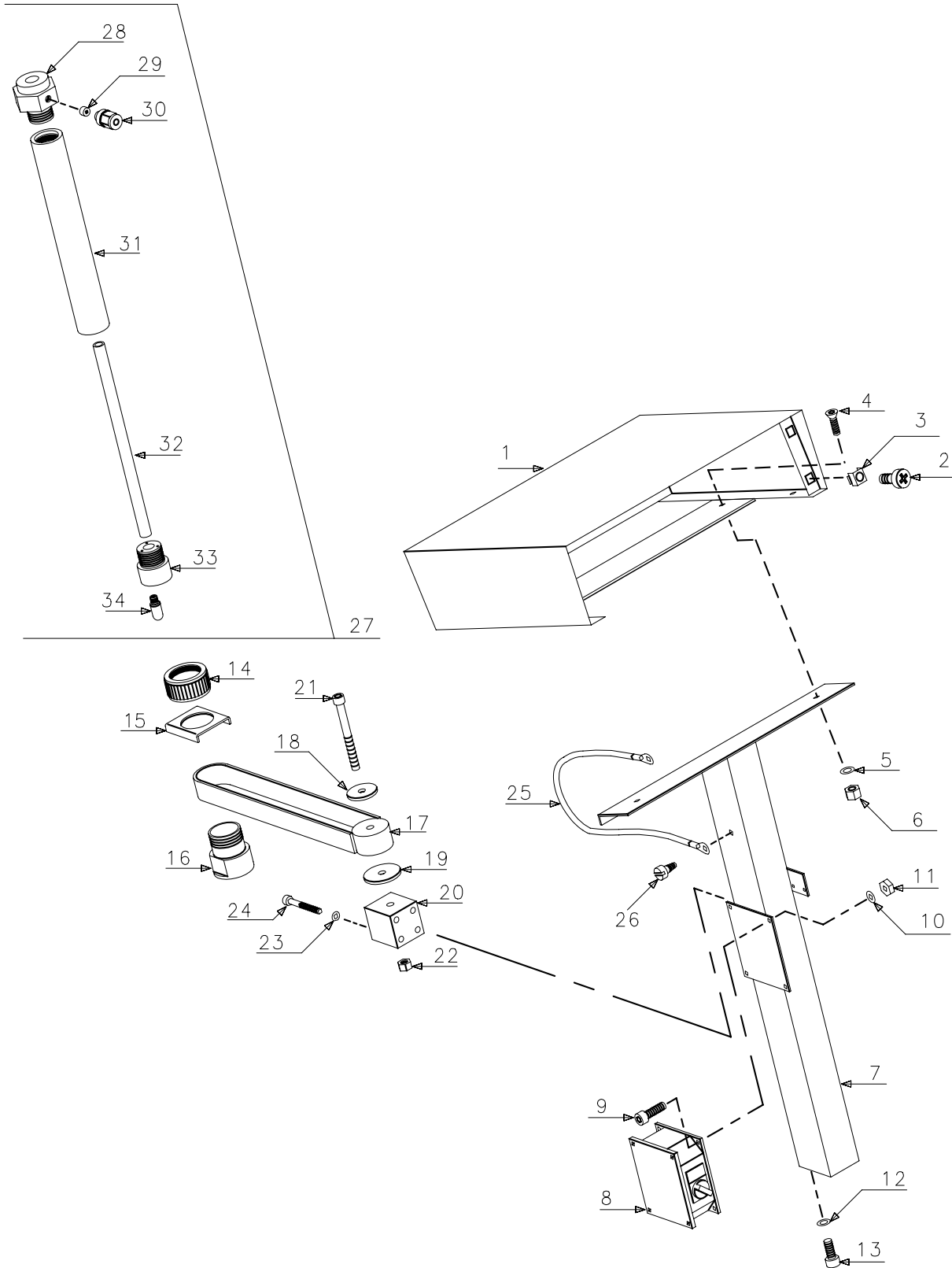



Pos.	Code	Description	Pos.	Code	Description
	5710	Complete rack support	18	5751	Washer
1	5875	Generator cover	19	5750	Friction washer di frizione
2	5591	Screw	20	5749	Block for swivel arm
3	5778	Slotted nut	21	5755	Screw
4	5583	Screw	22	5756	Nut
5	95063	Washer	23	34009	Washer
6	8042	Nut	24	7059	Screw
7	5746	Screw	25	5765	Grounding cable
8	5747	Washer	26	5768	Self-tapping screw
9	32029	Nut	27	5708	Powder suction complete hose
10	5876	Generator support	28	5743	Upper fitting
11	91154	Electric box	29	5745	Throttling
12	96030	Washer	30	11719	Automatic fitting
13	34008	Screw	31	5741	Suction hose
14	5752	Tube locking ring nut	32	5740	Powder hose
15	5754	Guiding support	33	5742	Lower fitting
16	5753	Suction tube guide	34	5744	Filter
17	5748	Swivel arm			



# N ELECTRO-PNEUMATIC GENERATOR

ATTENZIONE: per ogni particolare richiesto indicare sempre il Code e la quantità.

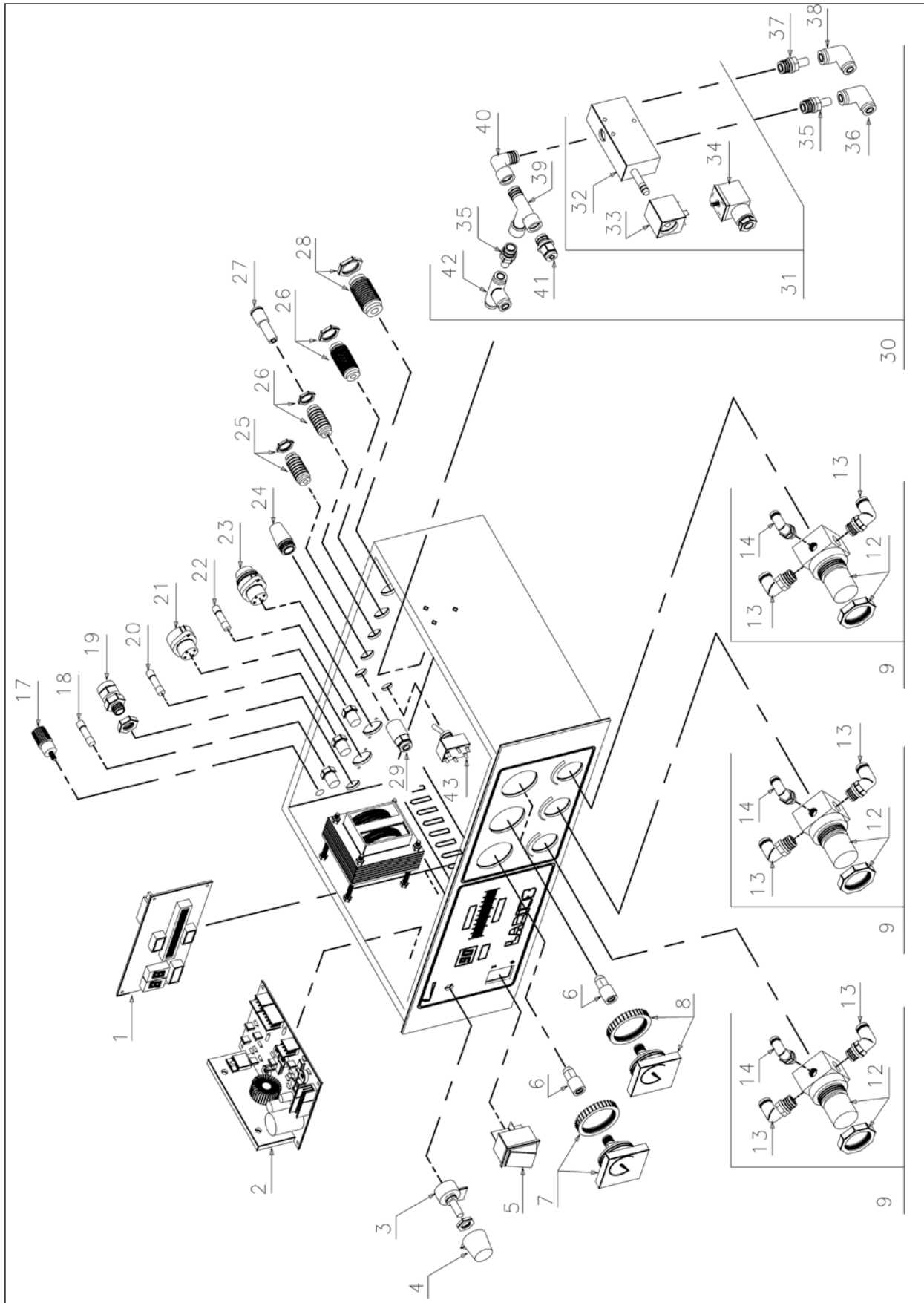



Pos.	Code	Description	Q.ty	Pos.	Code	Description	Q.ty
-	5920	Electro-pneumatic generator preset for CH 200 spray gun and Larius Tribo	-	22	9149	Fuse 1A	1
				23	5937	Connector for fixing automatic control cable	1
-	5101	Electro-pneumatic generator preset for CH 200 spray gun	.-	24	4018	Silencer	1
				25	5349	Fitting for tube ø 6	1
-	5922	Electro-pneumatic generator preset for Larius Tribo spray gun	-	26	5348	Fitting for tube ø 8	1
				27	5676	Fitting for tube ø 6	1
1	5929	Display board	1	28	5347	Fitting for tube ø 10	1
2	5603	Data processing board for CH 200	1	29	22016	1/4" Fitting for tube ø 8	1
	5925	Data processing board for CH 1200 and Tribo	1	30	5609	Solenoid valve complete with coil, connector, fittings	1
	5927	Data processing board for tribo-electric	1	31	5649	Solenoid valve complete with coil and connector	1
				32	5353	Solenoid valve	1
3	5931	Potentiometer	1	33	5627	Solenoid coil	1
4	5932	Potentiometer knob	1	34	5628	Solenoid coil connector	2
5	5933	ON-OFF switch	1	35	510019	1/4" Fitting ø 8	1
6	5346	1/8" Fitting for tube ø 4	3	36	4039	Elbow for tube ø 8	1
7	5341	Pressure gauge 0-6 bar	3	37	5597	1/4" Fitting ø 10	1
9	5787	Regulator complete with fittings	3	38	5359	Elbow for tube ø 10	3
				39	8032	1/4" fitting	1
12	5789	Air regulator 0-4 bar	3	40	5255	1/4 Elbow fitting	2
13	22015	1/4" Revolving elbow fitting tube ø 8	6	41	4006	1/4" Fitting for tube ø 8	1
				42	510020	"T" Fitting for tube ø 8	1
14	22014	1/8" Revolving elbow fitting tube ø 4	3	43	5935	Tribo-corona switch	
17	5566	Grounding terminal	1				
18	5158	Fuse 3.15 A	1				
19	5934	Power supply cable gland clamp	1				
20	9148	Fuse 2 A	1				
21	5936	Spray gun cable fixing connector	1				



# CH 200 MANUAL SPRAY GUN REF.9700

ATTENTION: for each part required always indicate the code and quantity.

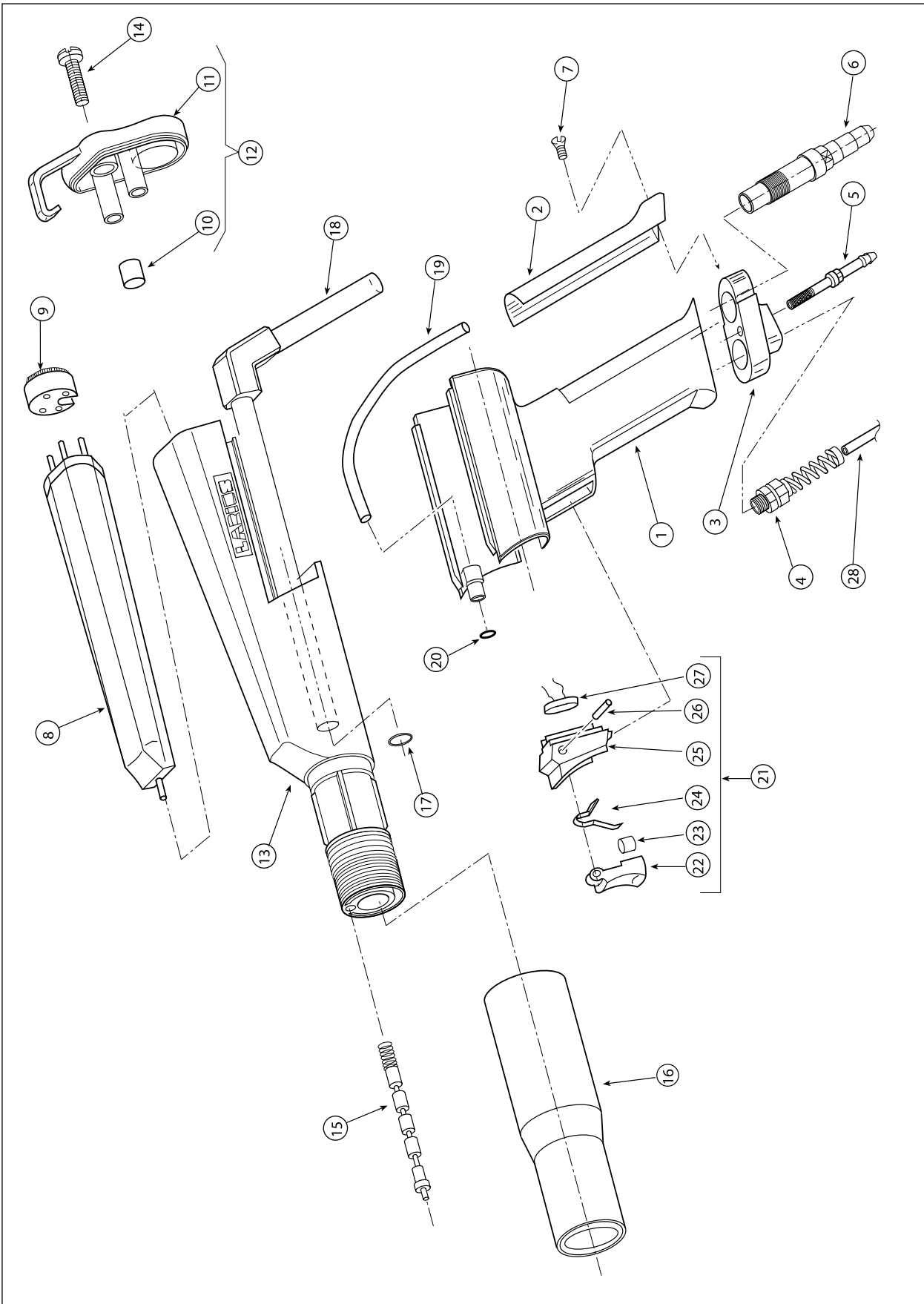



Pos.	Code	Description	Q.ty	Pos.	Code	Description	Q.ty
	9700	CH 200 manual Spray Gun	1	14	9803	Screw	1
1*	9752	Handgrip	1	15	9770	Electric resistance assembly	1
2*	9756	Grounding cover	1	16	9779	Ring nut	1
3*	9755	Terminal block	1	17	95326	O-ring	1
4*	9849	cable gland	1	18	9772	Powder passage tube	1
5	9762	Air passage tube fixing connection	1	19*	9761	Air tube	1
				20	4077	O-ring	1
6	9760	Powder passage tube fixing connection	1	21*	9763	Complete trigger	1
				22	9765	Trigger	1
7*	9819	Screw	1	23	5055	Magnet	1
8	9820	Multiplier	1	24	9792	Spring	1
9	9832	Connector	1	25	9764	Trigger support	1
10	9754	Check glass	1	26	9766	Trigger pin	1
11	9753	Rear cap	1	27	9769	Reed sensor	1
12	9703	Complete rear cap	1	28*	9900	Cable	1
13	9751	Complete front body	2				

\* Complete handgrip code 9945



## P SPARE PARTS FOR AUTOMATIC GUN CH 200 REF. 9705

ATTENTION: for each part required always indicate the code and quantity.

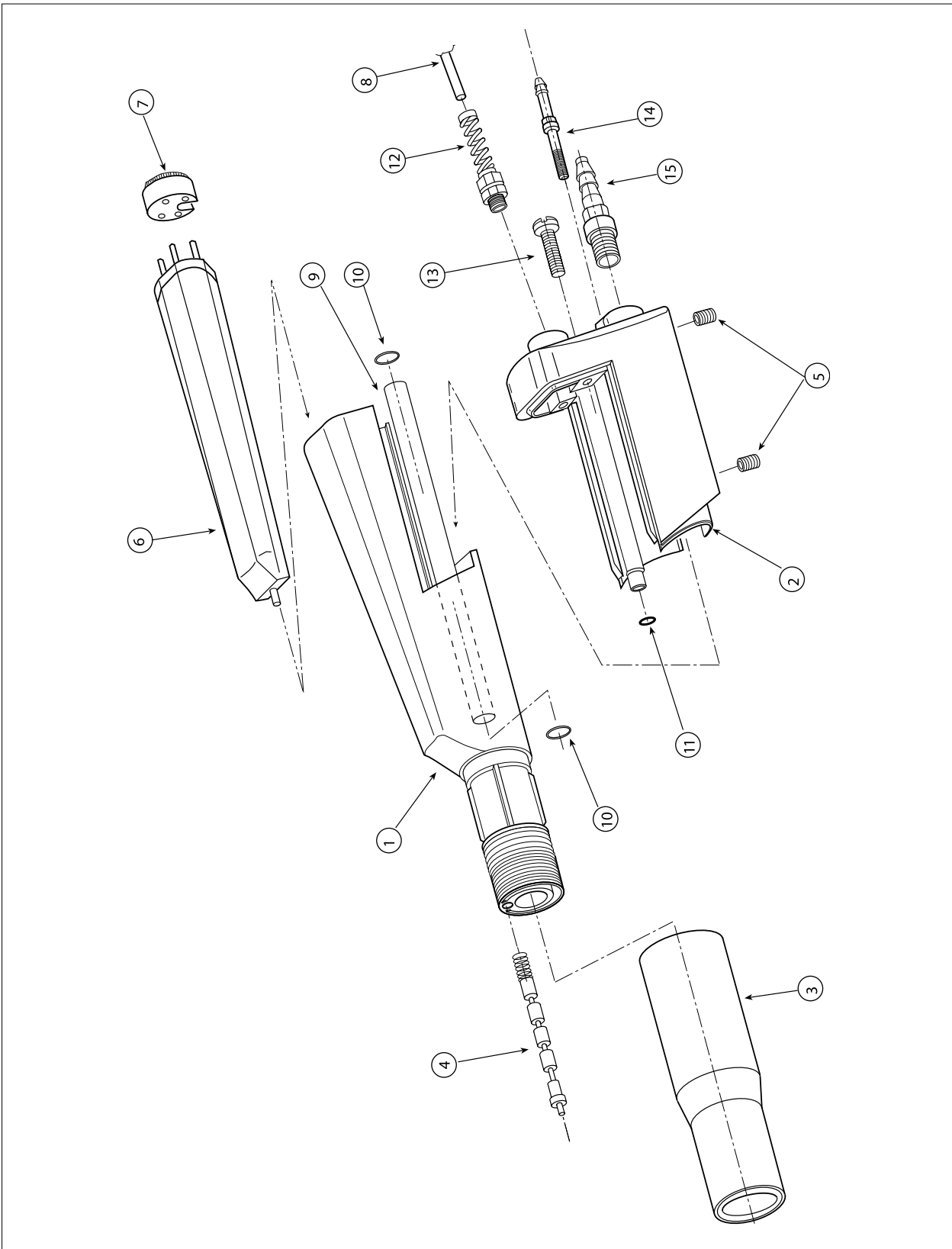



Pos.	Code	Description	Q.ty	Pos.	Code	Description	Q.ty
	9705	Automatic spray gun	-	8*	9900	Cable	1
1	9751	Complete front body	1	9	9802	Powder passage tube	2
2*	9801	Rear cap	1	10	95326	O-ring	1
3	9779	Ring	1	11	4077	O-ring	1
4	9770	Electric resistance assembly	4	12*	9849	Cable gland	2
5*	5546	Threaded inserts	1	13	9803	Screw	1
6	9820	Multiplier	1	14	9804	Air fitting	1
7	9832	Connector	1	15	5529	Powder inlet fitting	1

\* Complete rear cap code 9950



## Q SPARE PARTS FOR AUTOM. AND MANUAL TRIBO SPRAY GUN

**ATTENTION:** for each part required always indicate the code and quantity.

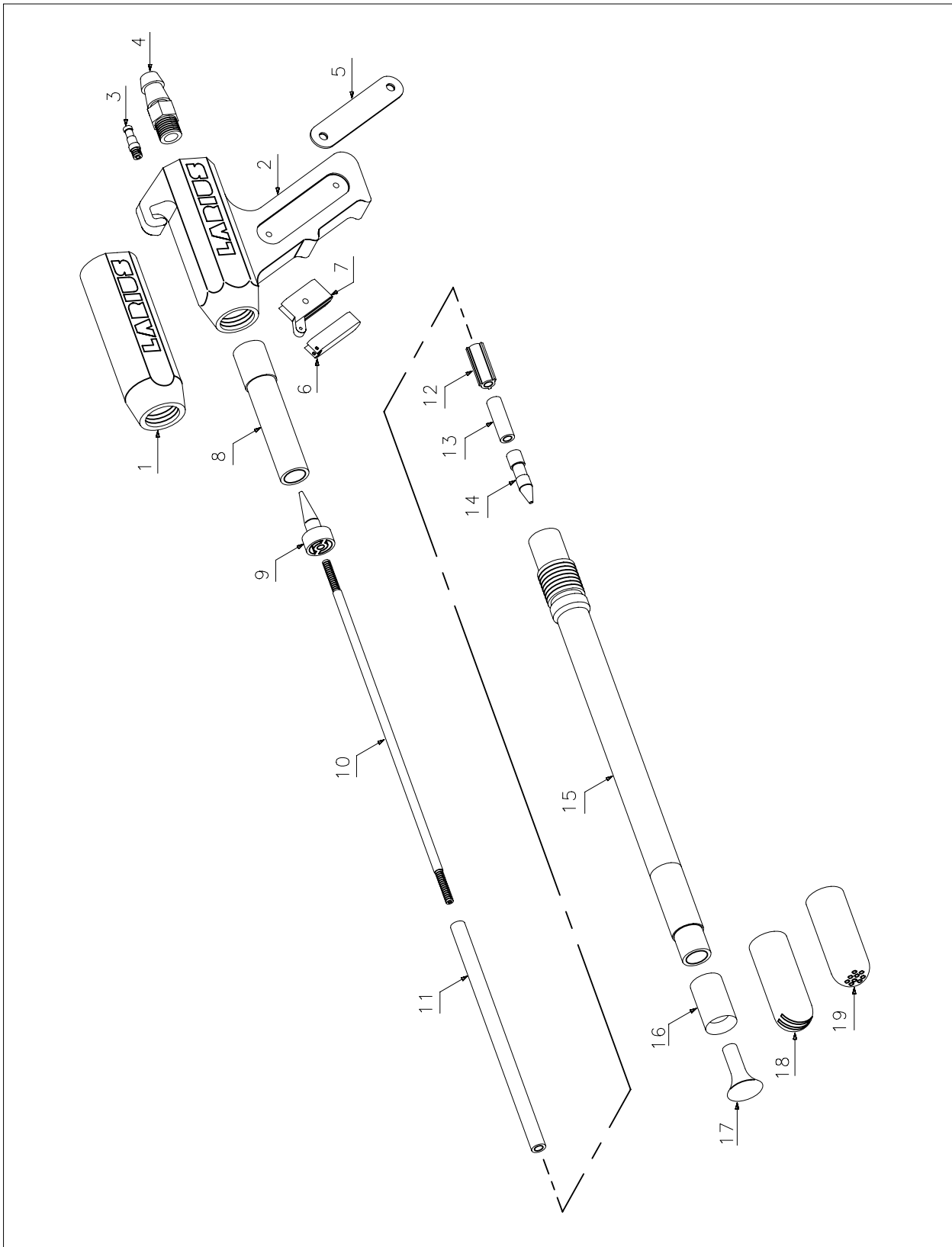



Pos.	Code	Description	Q.ty	Pos.	Code	Description	Q.ty
-	15200	Manual triboelectric spray gun	-	10	15262	Central rod length 400 mm	1
-	15203	Automatic triboelectric spray gun	-	11	15237	Tube	1
1	15211	Automatic spray gun body	1	12	15223	Spacer	1
2	15260	Manual spray gun body	1	13	15224	Tube	1
3	15226	Air passage tube fixing connection	1	14	15216	Diffuser holder fitting	1
4	15225	Powder passage tube fixing connection	1	15	15280	Complete charging tube	1
5	15268	Grounding plate	2	16	15298	Bush for cone jet nozzle	1
6	15264	Trigger lever	1	17	15297	Diffuser diameter 22mm	1
7	15265	Trigger body	1	17	15296	Diffuser diameter 26 mm	1
8	15220	Diffuser	1	18	15290	Flat jet nozzle	1
9	15217	Spacer cone	1	18	15293	30° flat jet nozzle	*
				19	15295	Nozzle with holes for round jet	*
					15221	Nozzle with 1 flat notch	*

\* Upon request



# R CONE JET NOZZLE SPARE PARTS FOR CH 200

L (mm)	Code	Description
90	9715	Standard nozzle

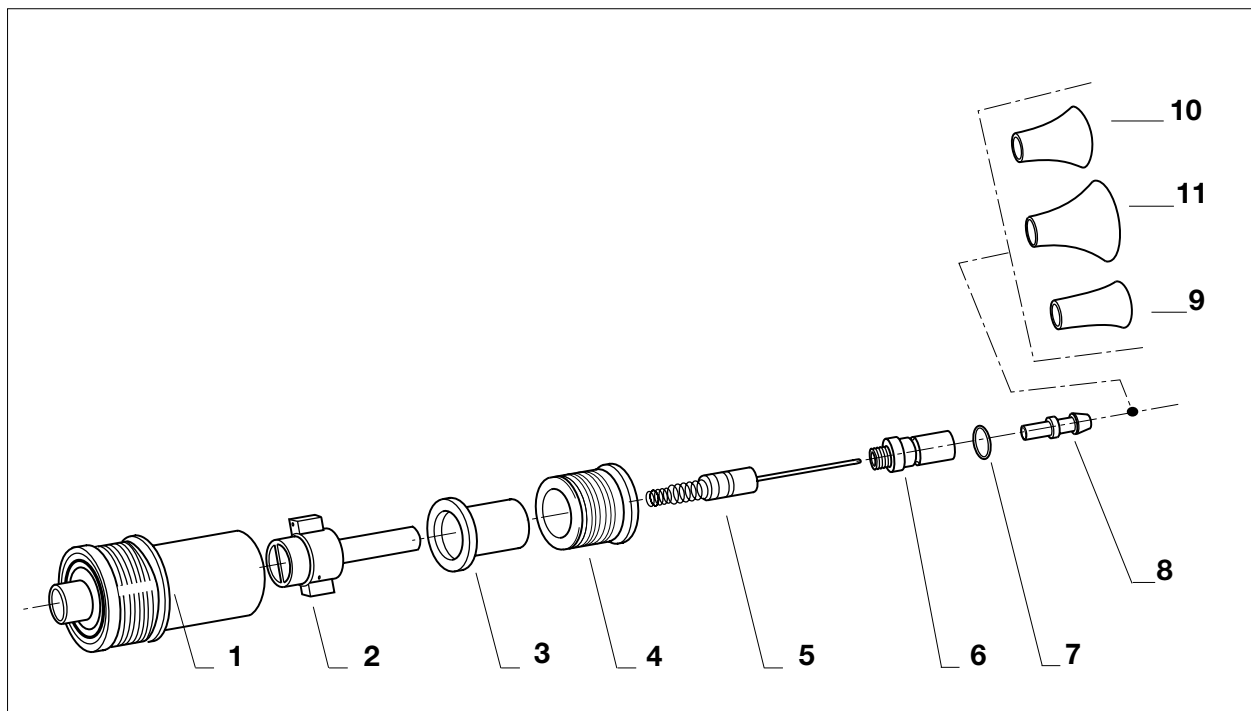
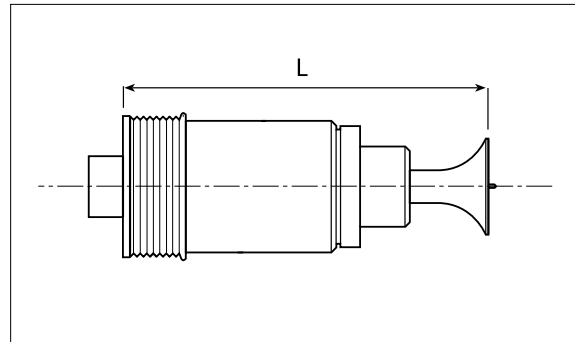

Pos.	Code	Description	Pos.	Code	Description
1	9865	Complete nozzle body (standard)	7	9895	O-ring
2	9866	Complete electrode holder	8	9857	Air diffuser
3	9861	Bushing	9	9858	Diffuser $\varnothing$ 16
4	9862	Ring	10	9859	Diffuser $\varnothing$ 24
5	9855	Complete electrode	11	9860	Diffuser $\varnothing$ 32
6	9856	Diffuser holder tip			



## S SPARE PARTS FOR CONE JET NOZZLE WITH EXTENSION FOR CH 200

L (mm)	Code	Description
160	9720	Medium nozzle
310	9725	Long nozzle
570	9730	Extra-long nozzle

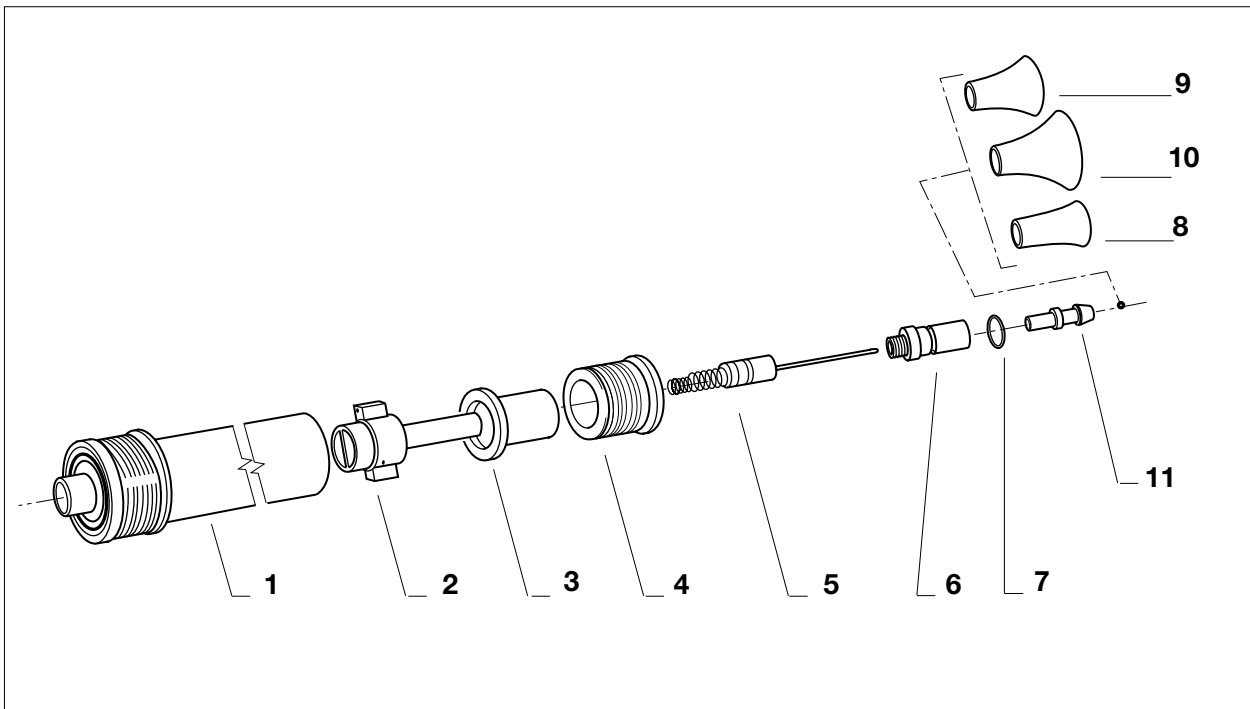
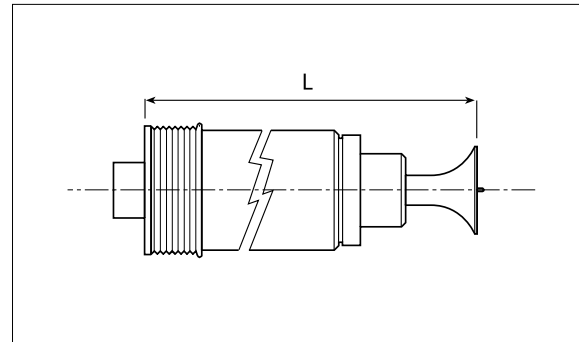

Pos.	Code	Description	Pos.	Code	Description
1	9885	Complete nozzle body (medium)	6	9856	Diffuser holder tip
1	9886	Complete nozzle body (long)	7	9895	O-ring
1	9887	Complete nozzle body (extra long)	8	9858	Diffuser $\varnothing$ 16
2	9866	Complete electrode holder	9	9859	Diffuser $\varnothing$ 24
3	9861	Bushing	10	9860	Diffuser $\varnothing$ 32
4	9862	Ring nut	11	9857	Air diffuser
5	9855	Complete electrode			



# T FAN NOZZLE SPARE PARTS FOR CH 200

L (mm)	Code	Description
90	9735	Standard nozzle
160	9740	Medium nozzle
310	9745	Long nozzle
570	9750	Extra-long nozzle

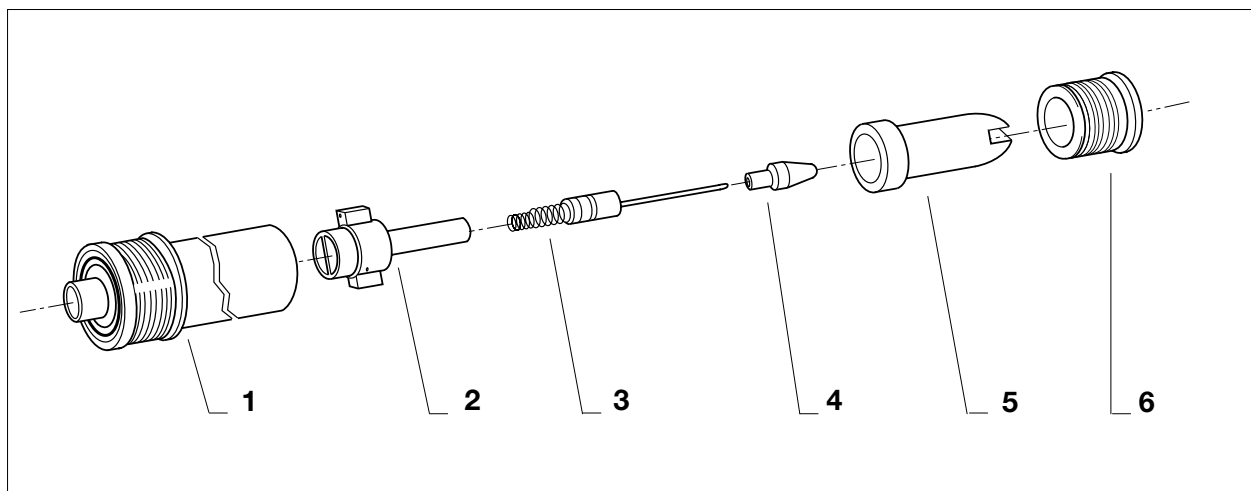
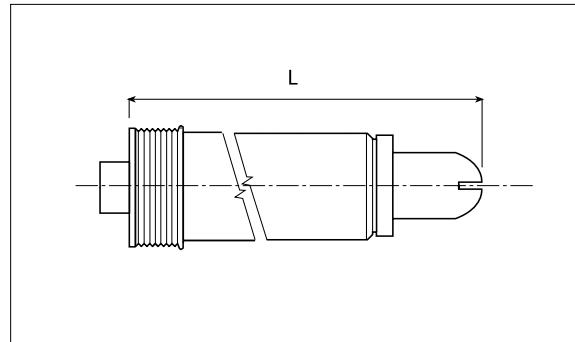

Pos.	Code	Description	Pos.	Code	Description
1	9855	Standard nozzle body	3	9890	Complete electrode
1	9885	Complete nozzle body (medium)	4	9891	Tip
1	9886	Complete nozzle body (long)	5	9892	Fan nozzle
1	9887	Complete nozzle body (extra long)	6	9862	Ring
2	9866	Complete electrode holder			



## U HIGH PERFORMANCE NOZZLE SPARE PARTS FOR CH 200

L (mm)	Code	Description
150	9815	Medium nozzle
300	9816	Long nozzle
560	9817	Extra-long nozzle

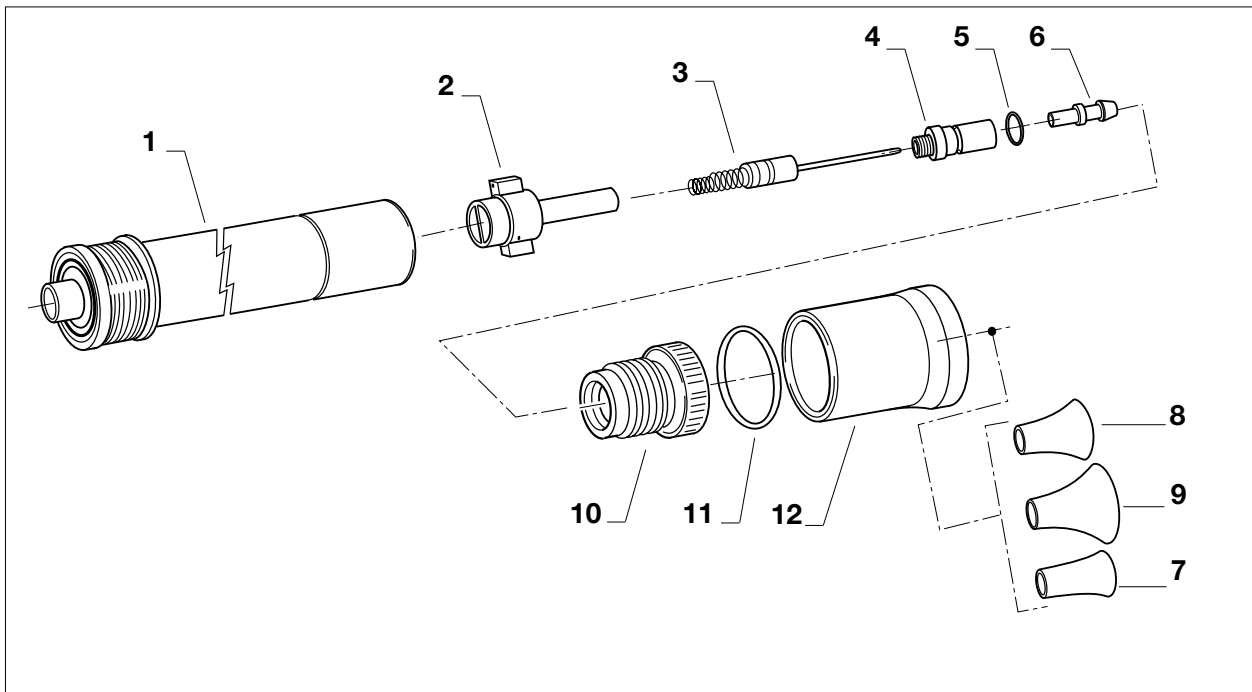
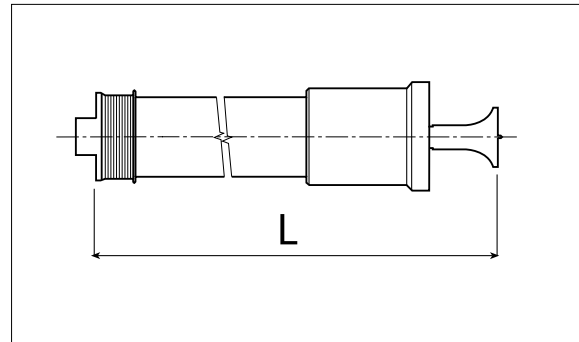

Pos.	Code	Description	Pos.	Code	Description
1	9920	Complete nozzle body (medium)	6	9857	Air diffuser
1	9921	Complete nozzle body (long)	7	9858	Diffuser ø 16
1	9922	Complete nozzle body (extra long)	8	9859	Diffuser ø 24
2	9923	Complete electrode holder	9	9860	Diffuser ø 32
3	9855	Complete central electrode	10	9925	Rheophore support
4	9856	diffuser support	11	11105	O-ring
5	9895	O-ring	12	5832	Jet adjustment bush



## V MULTI-DIFFUSION NOZZLE SPARE PARTS FOR CH 200

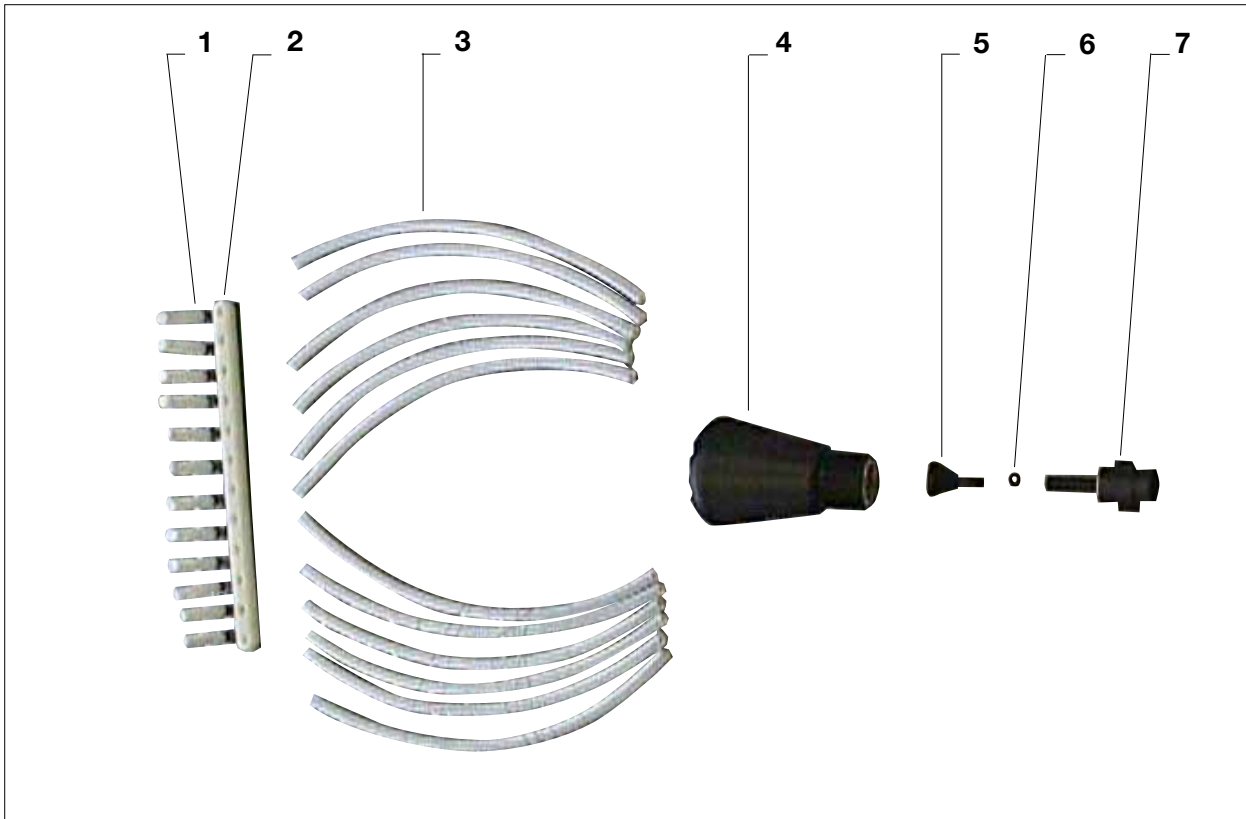

Pos.	Code	Description	Pos.	Code	Description
	9930	Complete multi-diffusion nozzle	2	9934	Tube supports
1	9936	Standard diffuser body 12 pcs.	3	9935	Series of tubes (specify number of pcs. required)
1	9937	Diffuser body with a central notch (upon request)	4	9955	Complete nozzle body
1	9938	Diffuser body with two 30° inclined notches (upon request)	5	9933	Conical diffuser
1	9939	Diffuser body with two 60° inclined notches (upon request)	6	9940	O-ring
			7	9956	Complete nozzle contact



## Z POWDER DELIVERY PUMP SPARE PARTS REF. 5505

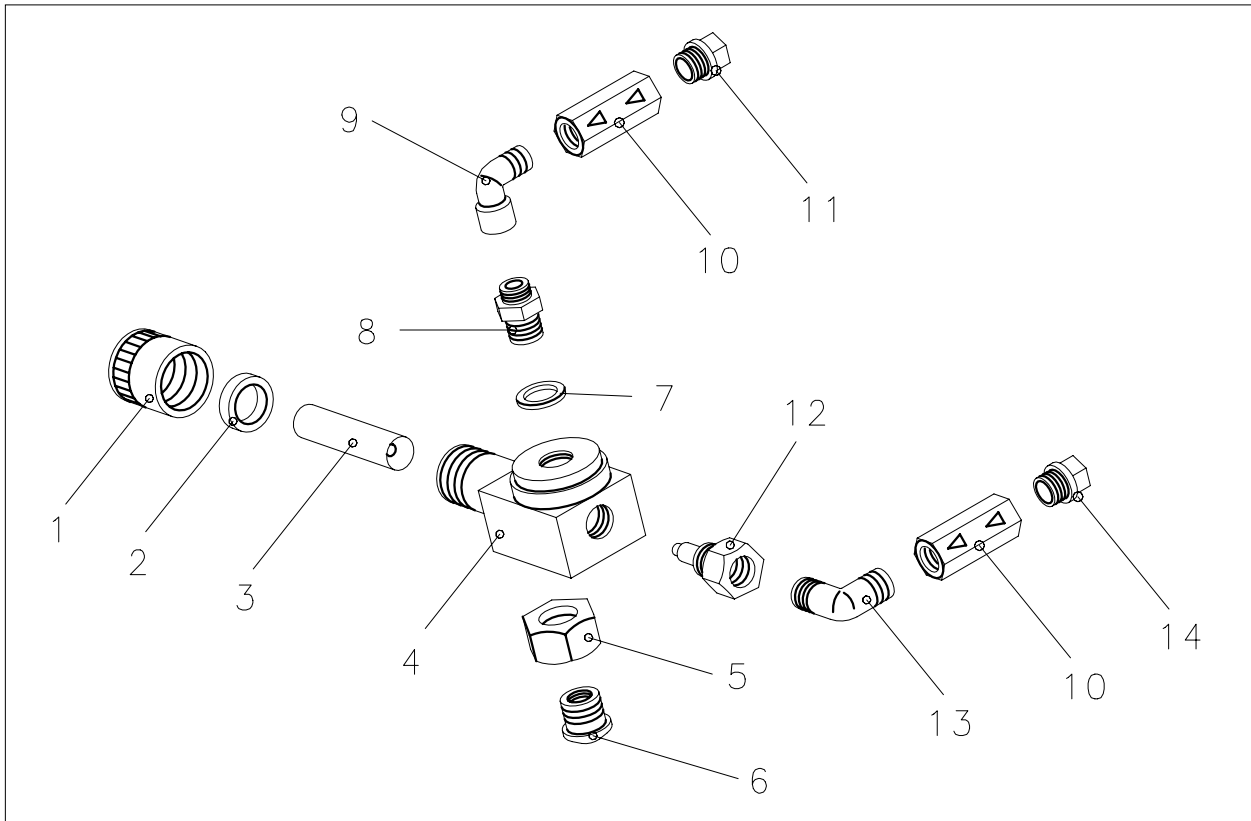

Pos.	Code	Description	Pos.	Code	Description
1	5297	Ring nut	8	5294	Fitting
2	5298	Ring	9	5255	1/4" Elbow M-F
3	9977	Venturi tube (Delrin)	10	9902	Unidirectional valve
	9977	Venturi tube (hard metal)	11	5313	Fitting for tube ø6
4	9976	Body	12	5288	Fitting
5	5291	Ring nut	13	3365	1/4" Elbow M-M
6	5290	Ogive	14	5312	Fitting for tube ø 8
7	32010	Washer			



## Y ACCESSORIES

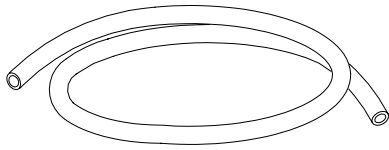

**Code 5243:**  
POWDER PASSAGE TUBE (PER METRE)

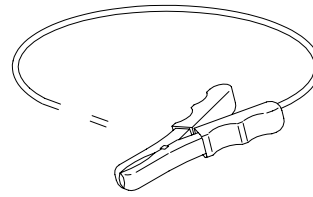

**Code 5010:**  
GROUNDING CABLE



**Code 5518:**  
BRUSH FOR CLEANING CH 200 SPRAY  
GUN

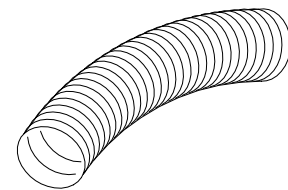

**Code 5573:**  
VENT TUBE (PER METRE)

# LARIUS

PAINT SPRAYING EQUIPMENT

*L'innovazione.  
Quella vera.*

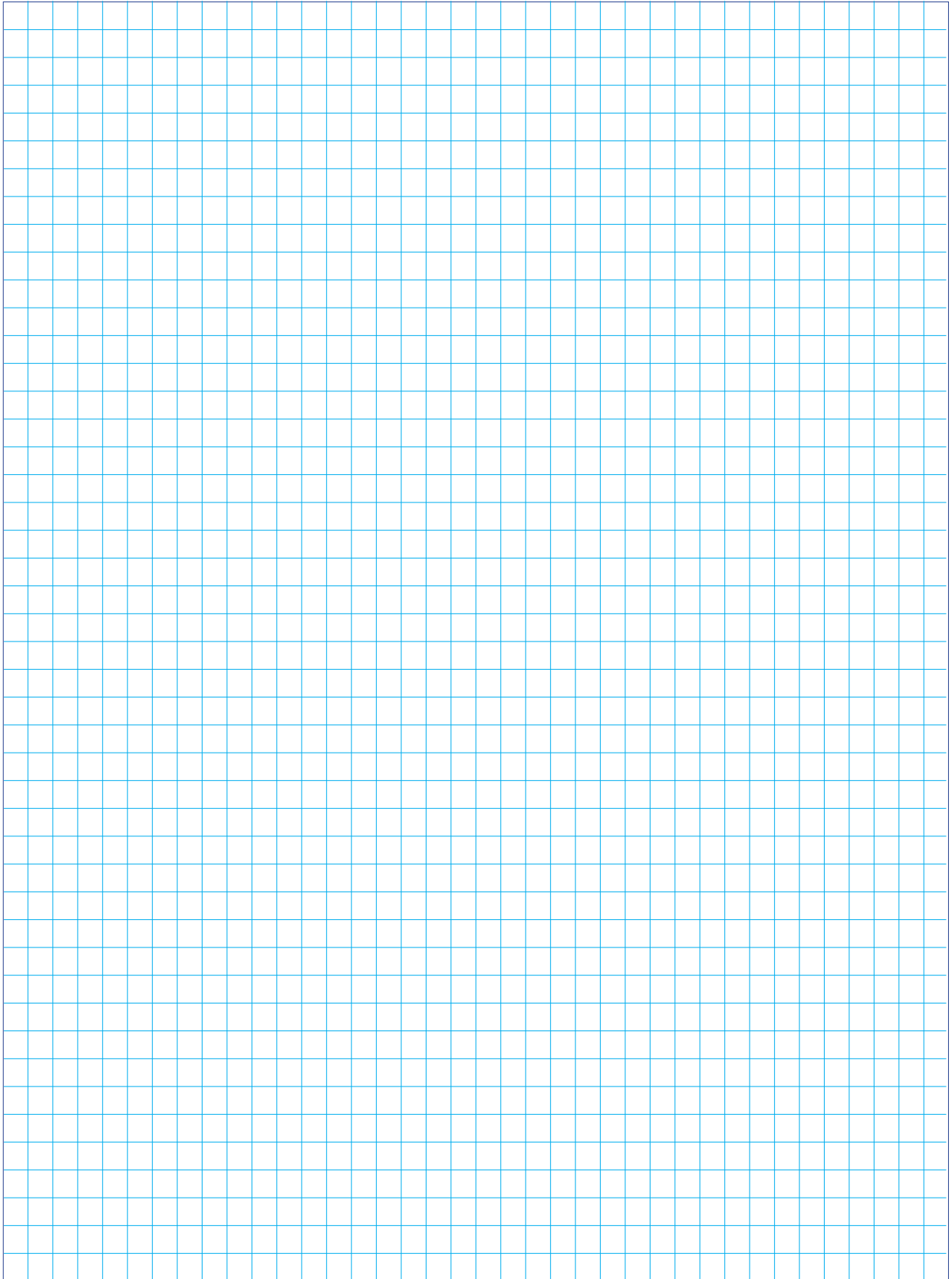



**LARIUS srl**  
Via Antonio Stoppani 21 - 23801 Calolziocorte (LC) ITALY  
TEL. +39 0341 621152 - Fax +39 0341 621243 - [larius@larius.com](mailto:larius@larius.com)

[www.larius.eu](http://www.larius.eu)

